

PRODUCT CATALOGUE 2011

ПРОДУКТ КАТАЛОГ 2011

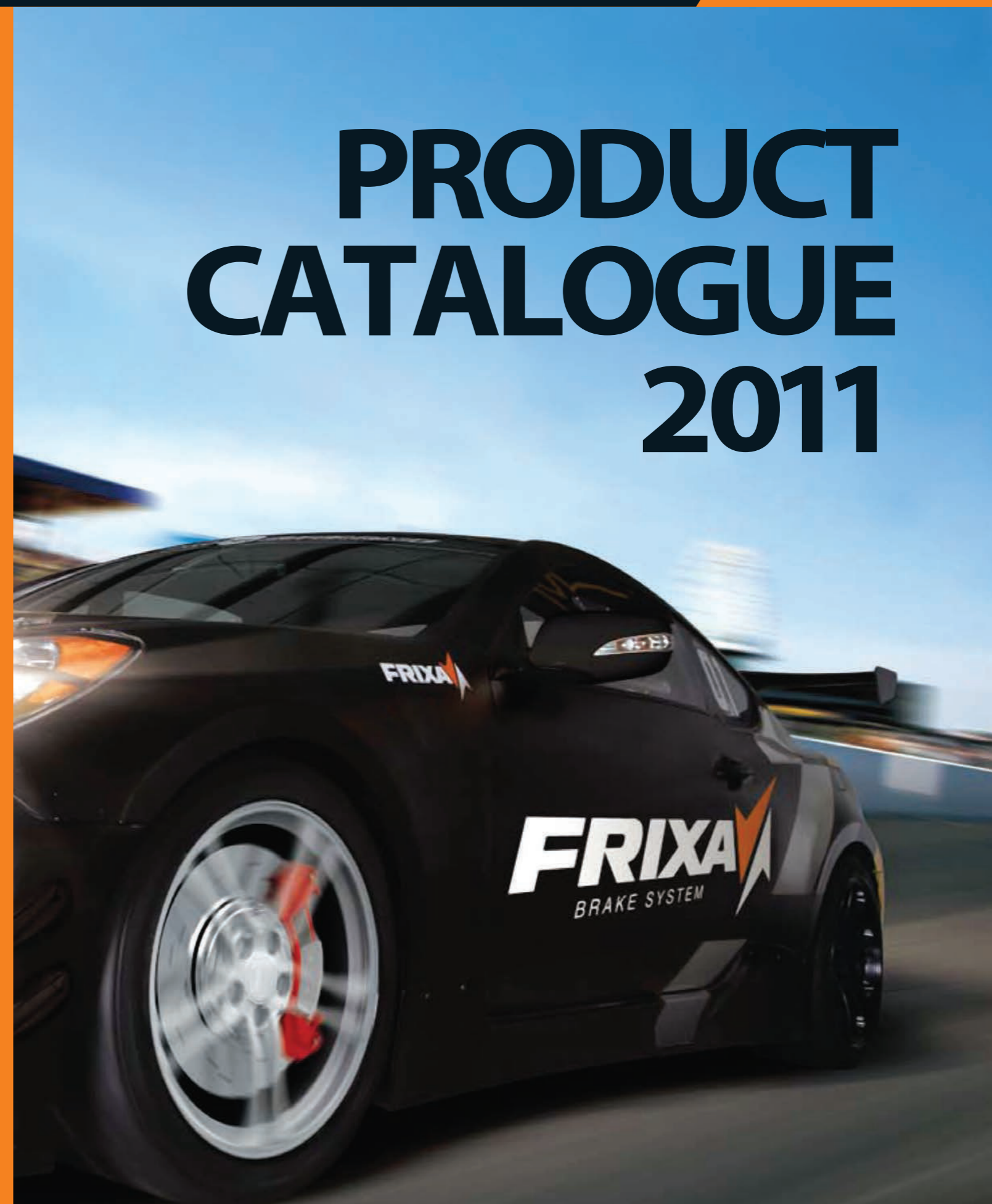

www.hankook-frixax.ru
E-mail: info@hankook-frixax.ru

«Эксклюзивный дистрибьютор торговой марки FRIXA»
Адрес: 127282, Москва, Чермянский проезд, д.7,
офис 3524, Бизнес-центр "На Широкой"
Тел./факс: +7 (495) 926-37-31





PRODUCT CATALOGUE 2011

Contents

FRIXA BRAKE SYSTEM



COMPANY INFO

- GREETINGS	P. 4
- HISTORY	P. 5
- CORE TECHNOLOGY	P. 6
- TECHNICAL CERTIFICATES	P. 7
- CORE TECHNOLOGY	P. 8
- TAXI / ULTRA	P. 10
- COMPETITION	P. 12
- LIGHT TRUCK	P. 14
- HEAVY-DUTY VEHICLE	P. 16
- INDUSTRY	P. 18
- DISC ROTOR	P. 20
- S1	P. 22

PRODUCT LIST

P. 24

DISC BRAKE PAD

HYUNDAI	P. 52
KIA	P. 75
CHEVROLET (GM-DAEWOO)	P. 94
SSANGYONG	P. 105
SAMSUNG~	P. 109
FOREIGN VEHICLES	P. 113

BRAKE SHOE ASSEMBLY

HYUNDAI	P. 146
KIA	P. 153
CHEVROLET (GM-DAEWOO)	P. 163
SAMSUNG	P. 167
LIGHT TRUCK	P. 169

BRAKE LINING

BLOCK LINING	P. 174
LINING - ONLY	P. 176

DISC ROTOR

VENTILATED BRAKE DISCS	P. 178
------------------------	--------

DISC BRAKE PAD					
FPH01	P.52	FPH04R	P.70	FPK26	P.89
FPH02		FPH05R		FPK27	
FPH02S	P.53	FPH09R	P.71	FPK28	P.90
FPH02F		FPH12R		FPK01NR	
FPH02NF	P.54	FPH17R	P.72	FPK04R	P.91
FPH04		FPH19R		FPK06R	
FPH05	P.55	FPH24R	P.73	FPK15R	P.92
FPH06		FPH25R		FPK20R	
FPH07	P.56	FPH26R	P.74	FPK25R	P.93
FPH08		FPHXGR		FPK26R	
FPH09	P.57	FPK01	P.75	FPK27R	P.94
FPH09N		FPK01N		FPD01	
FPH10	P.58	FPK03	P.76	FPD02	P.95
FPH10N		FPK04		FPD03	
FPH11	P.59	FPK04N	P.77	FPD05	P.96
FPH11N		FPK05		FPD06	
FPH12	P.60	FPK06	P.78	FPD07	P.97
FPH14		FPK07		FPD08	
FPH15	P.61	FPK07N	P.79	FPD09	P.98
FPH16		FPK08		FPD10	
FPH17	P.62	FPK09	P.80	FPD12	P.99
FPH18		FPK10		FPD13	
FPH19	P.63	FPK10N	P.81	FPD14	P.100
FPH20		FPK11		FPD15	
FPH21	P.64	FPK13	P.82	FPD16	P.101
FPH22		FPK14N		FPD17	
FPH23	P.65	FPK15	P.83	FPD18	P.102
FPH24		FPK16		FPD08R	
FPH25	P.66	FPK17	P.84	FPD10R	P.103
FPH26		FPK17N		FPD12R	
FPH27	P.67	FPK18	P.85	FPD12NR	P.104
FPHXDF		FPK19		FPD16R	
FPHXGF	P.68	FPK20	P.86	FPY01	P.105
FPHXGN		FPK21		FPY02	
FPH01R	P.69	FPK22	P.87	FPY03	P.106
FPH02NR		FPK23		FPY04	
		FPK24	P.88	FPY06	P.107
		FPK25		FPY03R	

FPY04R	P.108	FPE038	P.126
FPY05R		FPE039	
FPS01	P.109	FPE040	P.127
FPS02		FPE041	
FPS03	P.110	FPE042	P.128
FPS04		FPE043	
FPS05	P.111	FPE047	P.129
FPS01R		FPE048	
FPS01NR	P.112	FPS02	P.130
FPS03R		FPE053	
FPS05R	P.113	FPE057	P.131
		FPE058	
FOREIGN VEHICLES		FPE060	P.132
FPE011	P.113	FPE062	
FPE012	P.114	FPD07	P.133
FPE013		FPE064	
FPE014	P.115	FPE087	P.134
FPE015		FPE088	
FPE016	P.116	FPE089	P.135
FPE017		FPE090	
FPE06	P.117	FPE091	P.136
FPE018		FPE092	
FPE019	P.118	FPE096	P.137
FPE020		FPE097	
FPE021	P.119	FPE098	P.138
FPE022		FPE099	
FPE023	P.120	FPE100	P.139
FPE024		FPE101	
FPE025	P.121	FPE102	P.140
FPE026		FPE103	
FPE027	P.122	FPE104	P.141
FPE028		FPE105	
FPE029	P.123	FPE106	P.142
FPE030		FPE107	
FPE031	P.124	FPE108	P.143
FPE035		FPE109	
FPE036	P.125	FPE110	P.144
FPE037			

BRAKE SHOE ASSEMBLY

FLH01	P.146
FLH012	
FLH013	P.147
FLH02	
FLH02F	P.148
FLH06	
FLH07	P.149
FLH09	
FLH10	P.150
FLH11	
FLH12	P.151
FLH13	
FLH14	P.152
FLH16	
FLK01	P.153
FLK02	
FLKT02	P.154
FLK03	
FLK04	P.155
FLK07	
FLK08	P.156
FLK082	
FLK10	P.157
FLK10N	
FLK13	P.158
FLK14	P.159
FLK14N	
FLK15	P.160
FLK15N	
FLK16	P.161
FLK17	
FLK18	P.162
FLK19	
FLD01	P.163
FLD02	

FLD03	P.164	HT25R2	SM15TR
FLD04		HDTR	485R1
FLD07	P.165	HDT01	485R2
FLD08		HDT02	DWT01
FLD09	P.166	HDT03	ST20F
FLD10		FRTH04	ST20R
FLD11	P.167	FRTH05	ST20NR
FLS01		FRTH06	VT20F
FLE01	P.168	FRTH07	VT20R
		FRTH08,09	BT20NF
LIGHT TRUCK		106NFB	BT20NR
FLTH01	P.169	106NRB	BPW01
FLTH02		DT15F	ICP01
FLTH03	P.170	DT15R	ICP02
FLTH09		DT16R	
FLTH10	P.171	DC15TF	LINING - ONLY
FLTK01		DC15TR	FRTH01 P.176
FLTK02	P.172	DC23TR1	FRTH10
FLTK03		DC23TR2 P.175	FRTH11
		FX212F1	FRTH02
BRAKE LINING		FX212F2	FRTH03
BLOCK LININGS		FX212R1	FRTH12
540F1B	P.174	FX212R2	FRTH04
540F2B		FRTD01	FRTH05
540R1B		FRTD02	FRTH06
540R2B		927F1	FRTH07
54NR1B		927F2	FRTH08,09
54NR2B		927R1	FRTD01
HT15F		927R2	FRTD02
HT15R		949F	FRTK02
HS15F		949R	FRTK01
HS15R		949NR	FRTK03
HT20F		AT20	FRTK04
HT23F1		88F1	
HT23F2		88F2	DISC ROTOR
HT23R1		88R1	VENTILATED
HT23R2		88R2	BRAKE
HT25R1		SM15TF	DISCS P.178

Through innovative management and high-tech strategy for the best quality,

FRIXA searches for customers' dignity and becoming one of the highest standard global enterprises.

FRIXA is a member of the Hankook Tire Group of companies which has grown up to a global enterprise with customers' confidence and support, and came to participate in the brake system parts business for automobiles and industrial machinery, as a part of the Group's business line expansion programme.

Through continuous development of advanced technology and strict quality control, FRIXA has been recognized as a promising enterprise specializing in the friction material. Production of the environment friendly products and the car racing brake pads and the rotors especially, which is taken as the essence of the brake system technology, has made FRIXA acknowledged, at home and abroad, as one of the most prominent automotive parts manufacturers.

We are deeply grateful for customers' attention and support that has brought us to achieve all these things, and promise to reciprocate the kindest favor with our continuous passion and challenge to become a first class enterprise which takes customers' advantage more important than anything else.

Thank you.

CEO, FRIXA CO., LTD. **Choi, Hyeong-gi**

FRIXA, jumping lively towards the world.

Based on the certified technical capability, FRIXA plays a leading role in globalization of Korean technology.

FRIXA was established in August, 1991 with the head office and production site in Suncheon. It has been developing new products and improving the quality with the support of Hankook Tire R&D center in Daejeon, and supplying the products through Hankook Tire's distribution network. FRIXA has upgraded its production system by certification of TS16949 and ISO9001 in January, 2004.

FRIXA products protect driver's safety and enhance comfort with the excellent braking performance, thermal endurance, durability, low noise and minimized wheel dust. It is exporting the products to more than 20 countries all over the world.

- 1991 Company establishment
- 1966 Secured patents in Korea, U. S. A, Japan, Germany
- 1996 Certified of Korea Standard
- 2001 Created dedicated R&D division(Korea Industrial Technology Association)
- 2003 Certified of QS9000 and ISO9001
- 2004 First release of Premium Pad
- 2005 Selected as one of the best products in second half of 2005(by Hankook Ilbo)
- 2005 Certified of ISO/TS 16949 and ISO9001
- 2005 First release of racing brake pad
- 2006 Designated as a promising export small enterprise
- 2006 Contracted for authorized sponsorship of racing brake pads for Speed Festival held by KMRC
- 2007 Designated as a promising small enterprise
- 2008 Secured E mark (E9-90R-01.813/547) authorized by EU
- 2009 First release of racing disc rotor
- 2009 Disc brake pad was selected for an officially designated component for 2009 CJ O SUPER RACE held by KGTCR
- 2009 Awarded One Million US Dollars as export tower by Ministry of Knowledge and economy
- 2010 Continued Disc brake pad and disc rotor were selected for an officially designed components for 2009 CJ O SUPER RACE held by KGTCR
- 2010 Designated as small business of technical innovation
- 2010 Awarded various prize by Provincial Government
- 2010 Launched "SPY MOTORSPORT" for Caterham race car, UK
Launched "BURNETT MOTORSPORT" for Legend race car, UK

FRIXA, the most prominent brake parts manufacturer, producing value rather than products that provides both satisfaction in quality and care about the environments.

One-step-ahead science achieved by constant research and development is FRIXA's attraction.

Excellent braking power

FRIXA product's braking power is excellent, with average friction coefficient of 0.36-0.4 . There could be braking deviation depending on variation of speed or temperature, but FRIXA products maintain stable braking power under various circumstances.

Reduced Noise

Almost no noise of FRIXA product under 70dB provides comfortable driving. Braking noise produces displeasure and intensifies physical fatigue of driver. FRIXA product minimizes the noise for comfortable driving.

Minimized Wheel Dust

Metallic series materials of major cause of the wheel dust is minimized with FRIXA products, and high grade materials of aramid fiber and titanitic acid kalium instead is adopted for main materials, to reduce the wheel dust and maintain clean wheel condition.

High Grade Material



Titanitic Acid Kalium

- Excellent heat resistance, insulation and abrasion resistance
- Extended life span due to 3.5~4.0 times higher tensile strength than that of the normal material



Aramid Fiber

- High grade material of superior tensile strength and high elastic
- Minimized wheel dust due to less adhesion to wheel of the abrasion dispersion.

Minimized Damage to Disc Rotor

Damage to the disc rotor by brake friction material causes driver's displeasure or disturbs stable braking function. FRIXA products have minimized this.

Excellent Safety at High Temperature

FRIXA product's excellent fade-resistance at repeated braking under high temperature enables safe driving at all times. (Fade: The phenomenon that braking function is impeded by decrease of friction coefficient at high temperature of the friction material)



Environment friendly Products

FRIXA product's top priority is the environment and health, which do not have in the friction material ingredients the harmful heavy metals of Pb, Cd, Hg or Cr, neither the asbestos nor the glass fiber that may cause lung cancer if breathed in.

Technical Certificates



• Million Dollar Export Tower 2009

• E-Mark



• Form No.100697 Patent



• Form No.100698 Patent



• Form No.10-0784333 Patent



• Trademark registration card



• ISO/TS 16949



We guarantee accurate and safe braking
We manufacture and provide the products of all kinds of cars at home and from passenger car to light truck
The products of FRIXA has low noise in all vehicles



FRIXA composition

- 1 **Friction material**
Generates braking power by friction with disc.
- 2 **Slot**
A groove cut from the top in the middle of friction surface, along which dust worn by friction material is discharged and it also gives an effect of diminishing noise.
- 3 **Chamfer**
Both ends of friction surface ground to have them sloped down. It gives an effect of diminishing vibration and trembling.
- 4 **Sensor**
It indicates a limit beyond which friction material is not allowed to be worn. Two of four sensors per set is to be attached.
- 5 **Shim**
Prevents heat generated by braking from being transmitted to cylinder, thereby diminishing vibration and minimizing noise.
* It may not be necessary depending upon characteristics of vehicle.
- 6 **Back plate**
Steel plate to be fixed onto caliper. It bear weight of hydraulic cylinder.



FRIXA Core Technology

Excellent braking control(power)

With average friction co-efficient of 0.36 – 0.40 μ , it is excellent in braking power. Though in general braking deviation is caused by variation in speed and temperature, FRIXA is capable of stable braking power under any circumstances.

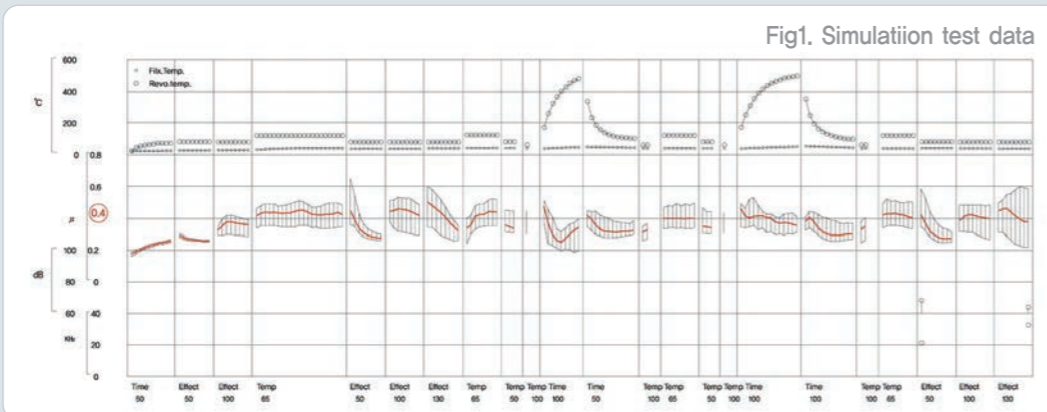

FRIXA CORE TECHNOLOGY

Reduction in noise

You can drive comfortably with virtually little noises(below 70db). In general, braking noise not only gives a driver unpleasant feeling but also makes him(her) very tired. FRIXA minimizes noise, thus enabling you to drive comfortably.

Keeping wheel dust to a minimum

Use of metallic materials, a major cause of wheel dust, is kept to a minimum and advanced materials such Aramid fiber, K2O etc. are adopted as major materials to diminish wheel dust, thus keeping wheels clean.

• Comparison of Wheel dust



FRIXA
Renders wheels clean by using advanced materials (wheel dust is kept to a minimum)



Others
Renders wheels contaminated by dust due to use of metallic materials such as steel fiber

• Use of advanced materials



K₂O 6TiO₂
– Excellent in heat-resistance, insulation and durability
– Extended lifetime due to tensile strength strong 3.5-4 times as much as general materials

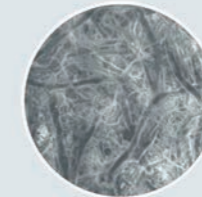

Aramid fiber
– Excellent in tensile strength and elasticity
– Wheel dust is kept to a minimum as only a little of worn dust is adhered to wheel surface.



Minimizes damage to disc rotor

Damage to disc rotor caused by brake friction material may give you unpleasant feeling while driving or a brake may not work in a properly stable condition. FRIXA minimizes damage to disc rotor.

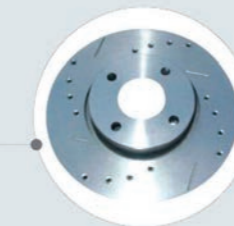

FRIXA minimizes damage to disc rotor using less metallic materials

Metallic materials like steel fiber cause damage to disc rotor, thus generating harsh noise and making it difficult for you to drive safely. FRIXA improves the problem by using less metallic materials.



Superb High Temperature Stability

Despite repeated braking in overheated condition (high temperature), it is superb in anti-fade property, thus enabling you to drive safely.

* Fade : When friction material is overheated, its friction coefficient drops, thereby losing braking power.

Eco-friendly product

Heavy metals i. e. Pb, Cd, Hg, Cr, hazardous to the human body are not used in friction material (pad). Asbestos and glass fiber which, if inhaled, cause lung cancer are not used either. FRIXA considers protection of environment and human health to be top priority.



Confidence in Perfect Control!

**Safety insurance for the customers!
You are already a rich man.**

Confidence in driving! The confidence may have some reasons. Find the answer with FRIXA. With the FRIXA "Taxi", the life span of the friction material is extended by about 40% than that of the normal products with the NAO series ingredients in the material, the wheels can be cleanly maintained all the time because the wheel defilement is reduced with the ingredients of the high-tech fiber of the kevlar and potassium titanate instead of the steel fiber, which is the main cause of such defilement by dusts from braking, and the disc rotor abrasion also is reduced.

Excellent braking · Reduced Noise · Minimized Disc Rotor Abrasion · Environment-friendly Products · Minimized Wheel Dust



FRIXA Taxi Core Technology

Excellent Braking : It has excellent braking efficiency, abrasion resistance and reduced noise, which is good for such vehicles that require abrasion resistance as those for commercial use. Average friction coefficient is 0.36-0.40 μ level, and it allows stable braking performance even at the time of instant or repeated stops, because the braking declination is reduced.

Extension of Life Span : Its life span is about 40% longer than that of the normal products for passenger cars.

Reduced Noise : Braking noise produces displeasure and intensifies physical fatigue of driver. FRIXA product minimizes the noise for comfortable driving.

Minimized Damage to Disc Rotor : Generally, the product of improved abrasion resistance causes more damage to disc rotor, but FRIXA TAXI produces transition layer on its surface at the time of friction to minimize the damage to the disc rotor.

Environment Friendly Product : It protects pad replacement worker's health, because it does not have in the friction material the harmful heavy metals of Pb, Cd, Hg or Cr, neither the asbestos nor the glass fiber that may cause lung cancer if breathed in.

Minimized Wheel Dust : It produces only a little amount of wheel dust and keeps the wheels clean all the time.

FRIXA Ultra Taxi Core Technology

Extension of Life Span : Its life span is more than 100% longer than that of the normal pads for passenger cars.

Excellent Braking : Average friction coefficient is 0.36-0.40 μ level, which ensures stable braking performance even at the time of instant and repeated braking.

Comfortable Driving with Low Noise : Braking noise is minimized to allow comfortable driving.

Less Wheel Dust : Wheel dusts sticking to the wheel is minimized to keep the wheels clean all the time.

Minimized Damage to Disc Rotor : It produces film layer between the friction material and the disc, which reduces the damage to the disc rotor and abrasion of the pad.

Products Characteristics Comparison

► FRIXA Taxi

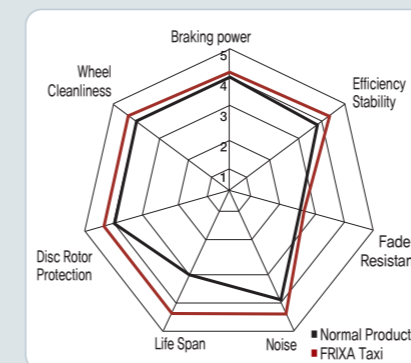

► FRIXA Ultra Taxi

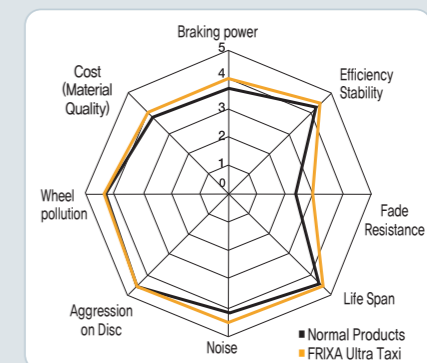



Confidence in Perfect Control!

Slugout of 0.01 second!

FRIXA COMPETITION has been developed for car racers and speed mania. With the high function compound material of the ceramic fiber, it exercises strong braking capacity (high temperature braking power 0.30–0.45). The braking power and the stability also has been improved for the competition for 0.001 second, with minimized braking declination at high temperature and fade control at repeated braking.

Pad for expert racing, Blazing Red Color Back Plate, Strong Braking Power with Minimized Braking Declination at High Temperature, Fade Control at High Temperature and Repeated Braking (workable at ultra high temperature of 800°C), Application of Scorching Method. Increased Initial Bite



FRIXA CORE TECHNOLOGY

Strong braking capacity for Racing

FRIXA COMPETITION is optimized for racing with the friction coefficient of 0.30–0.35 μ level for COMPETITION "A" and the 0.38–0.45 μ level for COMPETITION "B", while that of the normal pads under the racing is 0.25–0.15 μ level.

Stability at High Temperature

When the average friction coefficient is high, braking declination occurs depending on the change of speed and braking temperature, but FRIXA COMPETITION maintains excellent braking stability and fade resistance in such changes.

Abrasion Resistance at High Temperature

Racing pad has to have abrasion resistance at high temperature, because it has to work frequently at high speed and high temperature. FRIXA COMPETITION is suitable for racing with its braking power and stability as well as the abrasion resistance.

※Usable Temperature Range: 300–800°C

Improved Adhesion Strength at High Temperature

High temperature is produced during racing from the speed reduction and braking at ultra high speed, and the friction material may separate from the back plate under the high temperature. For FRIXA COMPETITION, the strength reinforced back plate is developed by FRIXA's patent technology, to improve the adhesion strength and prevent such separation under high temperature.

Verified Performance

FRIXA COMPETITION is being used at Korea's most prominent professional racing competition of the CJ Super Race 3800 Class, 2000 Class and 1600 Class, receiving applausive responses from all the racers of the participating teams.

Simulation Test Data

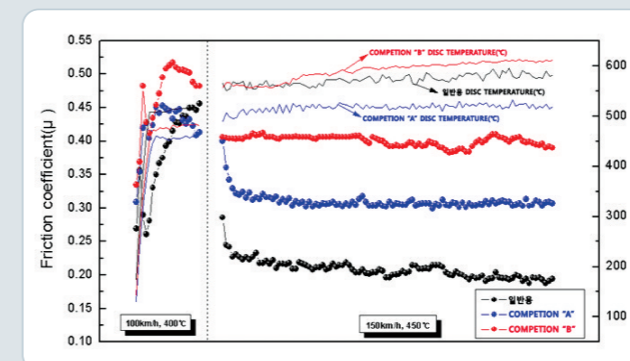

Products Characteristics Comparison

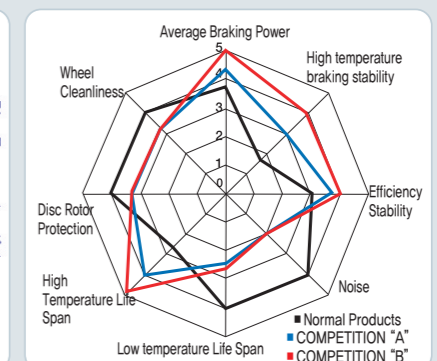



Confidence in Perfect Control!

So, you are safe!

FRIXA Light Truck has been developed with the top priority given on the driver's safety, to exercise stable braking power under such diverse operating conditions for the light trucks, as the different cargo loads or various road conditions, and to maintain constant braking performance at high temperature frequently produced by repeated braking.

**Excellent braking · Reduced Noise · Least Damage to Disc Rotor
Environment-friendly Product · Least Wheel Dust**

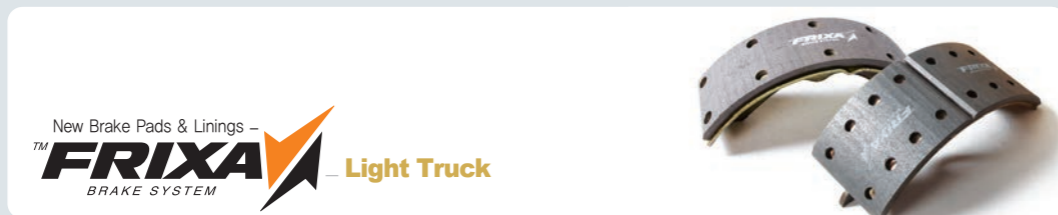

FRIXA CORE TECHNOLOGY

Excellent Braking : FRIXA LT is designed to minimize the brake slide phenomenon with the advanced high grade material to ensure stable braking power at high speed driving or the instant and repeated braking.

Minimized Noise : Braking noise produces displeasure and intensifies physical fatigue of the driver. FRIXA LT minimizes the noise and vibration for comfortable driving.

Extended Life Span : With the high grade material, the life span is extended to be 1.5 times of the normal pads.

Anti-Vibration Chamfer : The chamfer on each end of the lining reduces vibration to help comfortable driving.

Convenience : Wear limit line shows the lining replacement time.

Excellent Stability : The steel rivet strengthens the combination of the lining and the shoe to prevent the lining's escape from the shoe.

New Concept Brake Lining satisfying all the demands of braking power, Low Noise and Extended Life Span!

Simulation Test Data

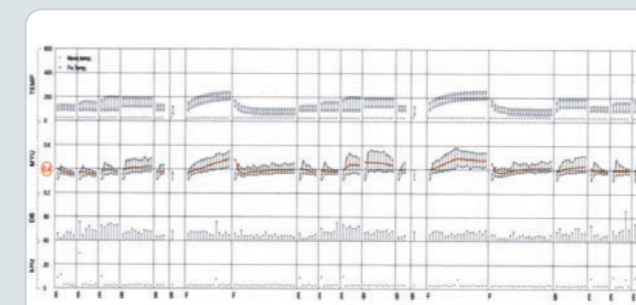

※ The smaller deviation between the highest and the lowest point of the red line means the better quality.

Products Characteristics Comparison

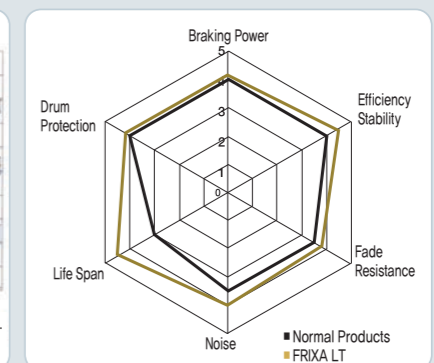

We guarantee accurate and safe braking We manufacture and provide the products of all kinds of cars at home and from passenger car to light truck The products of FRIXA has low noise in all vehicles



Confidence in Perfect Control!

Take-off for Northeast Asian Logistics Hub!

For the take-off for Northeast Asian logistics hub, specialization of logistics and reduction of logistics cost is very important. With the high-tech materials, the life span of FRIXA Heavy Duty Vehicle is significantly extended. Logistics specialist choose FRIXA's Heavy-duty Vehicle FX lining. Besides the reduction of logistics cost, it ensures safe drive back home.



FRIXA CORE TECHNOLOGY

Strong Braking Power for Heavy-duty Trucks

FRIXA HEAVY-DUTY VEHICLE's average friction coefficient(0.40-0.45 μ for pad, 0.35-0.40 μ for lining) is suitable for the characteristics of the heavy-duty tractors or the heavy-load dump trucks, demonstrating excellent braking power.

Fade Resistance at High Temperature

Its fade resistance is excellent, which means it maintains constant friction force under the high temperature caused inevitably by braking of the heavy trucks with weighty loads.

Stability at High Temperature

It maintains constant friction force and stability at high temperature, regardless of the velocity of the vehicle or the pressure on the brake pedal.

Extended Life Span

It assures superior life span to other products with the excellent heat resistance and fade resistance under the high temperature which frequently occurs to the heavy duty trucks.

Minimized Aggression on Counterpart

The friction compound's aggression on counterpart is minimized to protect the disc rotor and the drum and prevent noise at braking.

Simulation Test Data

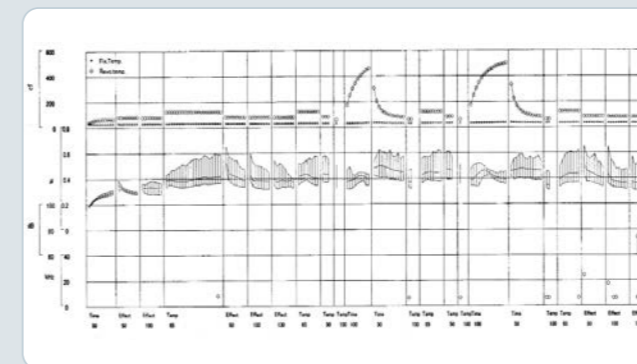

Products Characteristics Comparison

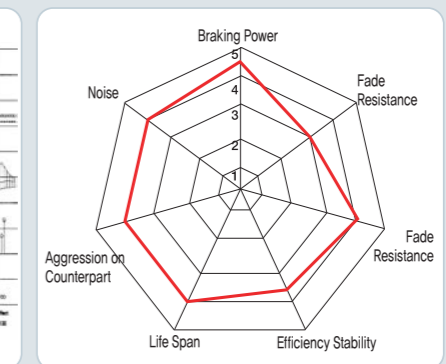

PRODUCTS



We guarantee accurate and safe braking We manufacture and provide the products of all kinds of cars at home and from passenger car to light truck The products of FRIXA has low noise in all vehicles



Confidence in Perfect Control!

Realization of Highest Level Safety at Industrial Sites!

FRIXA INDUSTRY will secure safety of your industrial site with the brake products of highest braking performance. It has been developed through combination of the friction product manufacturing know-how and the material technology, to maintain stable performance by minimizing braking deviation under the high temperature produced by frequent and repeated braking.



FRIXA CORE TECHNOLOGY

Excellent Braking Power

FRIXA INDUSTRY is the friction product to lower the speed of or stop the machineries at industrial sites, and maintains excellent braking performance even at continuous friction actions.

Product of Longevity

Manufactured with high grade raw material and high-tech production method, it commands much longer life span than other products.

Stable Friction Characteristics

The most ideally harmonized lubricating ingredients enables stable friction characteristics and prevents possible noise under most of the circumstances.

Customized Product

Various types and sizes are produced depending on the nature of the demand for industrial use, and each customer's requirement is fully respected and satisfied.

Main Items

- Brake for Hoist
- Brake for Earthmoving Equipment
- Motor Reducer

Simulation Test Data

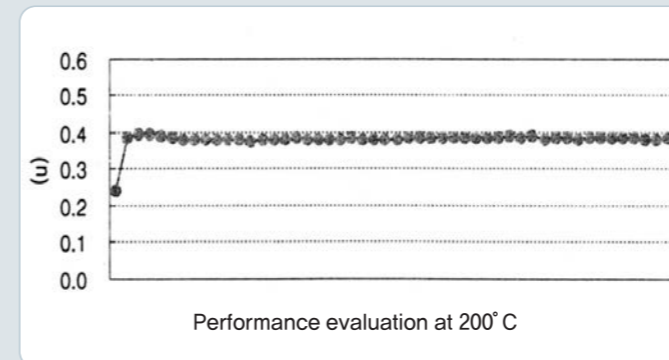

Products Characteristics Comparison

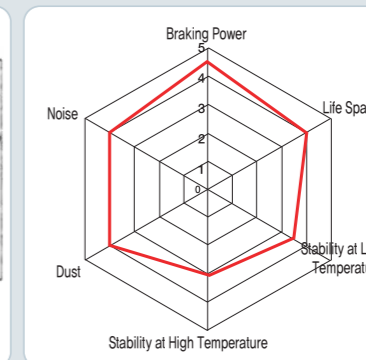

PRODUCTS



We guarantee accurate and safe braking
We manufacture and provide the products of all kinds of cars at home and from passenger car to light truck
The products of FRIXA has low noise in all vehicles



Confidence in
Perfect Control!

DISC ROTOR RACING & TUNING

Special Weapon! FRIXA releases High Carbon 2 Piece Light Weight Rotor!
Tune up to FRIXA Spiral Rotor of optimized fade resistance, composition uniformity, tensile strength, heat conductivity and yield strength, which brings you better radiation, higher fuel efficiency and improved braking performance!

Stable Braking, Reduced Noise and Judder, Durability(Abrasion Resistance · Heat Deflection Resistance Crack Resistance), Improved Radiation, Light Weight

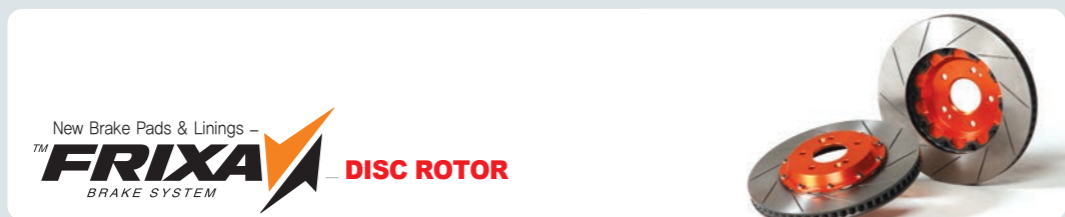

FRIXA CORE TECHNOLOGY

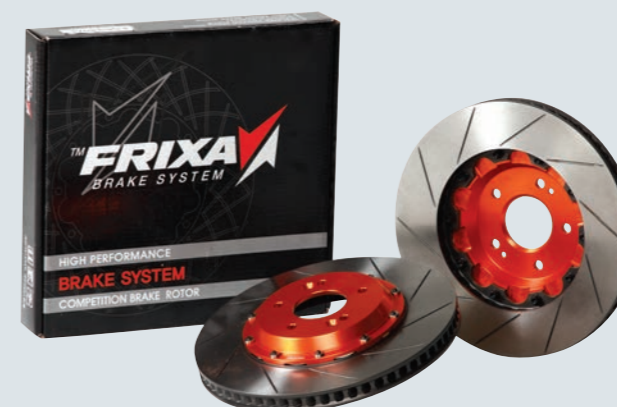

Higher braking stability and maximized radiation at high temperature with the innovational 76Fin application.

The heat of the disc produced by its friction against brake pad is cooled by ventilating fins, and FRIXA brake disc is designed to maximize the radiation efficiency with the improved shape and increased number of the ventilating fins.

- FRIXA Brake Disc is the left-right divided type fin shape in spiral form, while the original brake disc is in straight form.
- The first 76 fin in Korea, improving the cooling capacity by 30-40% against other competing products.
- Crack Resistance.
- Having more ventilating fins is advantageous for a brake disc, but it brings about the challenge of achieving mechanical uniformity and light weight design. FRIXA Brake Disc is born with the optimum performance from the technology and know-how accumulated by the research and development works in the racing field for the last 5 years.



Choice of optimum slit through analysis of running environment.

- Slit design of optimum number, length and shape through analysis of running environment for sport and racing.
- Variety of FRIXA's own slit types will be shown on the brake discs to be newly released.

Heat Treatment to improve the Durability

- Casting stress release of the disc by the heat treatment at the temperature reachable by its friction activity.

Verification of the Product Performance in Racing Competition

- FRIXA Brake Disc has been designated as the officially approved parts for the Genesis Coupe One make 3800 class of the CJ O super-race, the most famous professional racing competition in Korea.



Premium edition
FRIXA S1

With more superb performance than that of original version.

FRIXA S1 is a choice of smart customers. You will be extremely satisfied with its superb performance and reasonable price level.



1 Adoption of Double slot
It prevents dust from being stuck to slot or disc surface which causes braking control to be deteriorated. It also plays a role of lowering high temperature caused by friction.

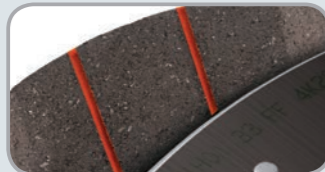

2 Adoption of rubber coating shim
It prevents vibration and heat caused by friction from transmitting to caliper. It reduces noise/vibration and maintains stable braking power.



3 Back plate color
Applies luxurious silver color and texture.

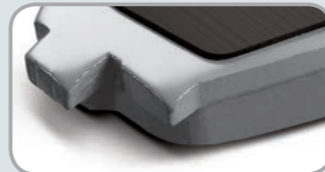

FRIXA CORE TECHNOLOGY

Safe Driving!

FRIXA S1 tells about essence of automotive brake.

- * In auto races requiring extreme braking performance, Frixia S1 is the only brake pad in Korea that competes with globally known brands of brakes.
 - Nominated as official parts by 'CJ O Super Race'(the biggest auto race in Korea) for its main event of the Super 3800 Class(Genesis Coupe Race).
 - Exclusively supplied to SPY-Motorsport, a the champion team of the 'Super light R300 Championship 2009' in United Kingdom.
- * FRIXA S1, where cutting edge racing technology is applied, keeps your safety under any circumstances by realizing high degree of braking control and stability at the same time.
 - Average friction co-efficient exceeds 0.43 μ (0.37 μ for our previous version)

Sensuous Experience!

FRIXA S1, New experience with eco-friendly driving.

- * Adopts NAO (Asbestos-free eco-friendly material) compound (??) technology which minimizes content of steel, the cause of brake noise, and dust and hard touch.
- * No longer brake noise harsh to your ears and sluggish reaction speed. FRIXA S1 enables you to feel something smooth at the tip of your toes, reacting sensitively to what you are doing. It gives you pleasure of real driving.

Smart Choice!

FRIXA S1 is a choice of smart customers.

- * You, insisting upon an original! You are entitled to be assured of safety by far better performance.
- * FRIXA S1, introduced at reasonable price level, serves your needs to your complete satisfaction with highest performance-to-price.

Performance comparison table between premium products

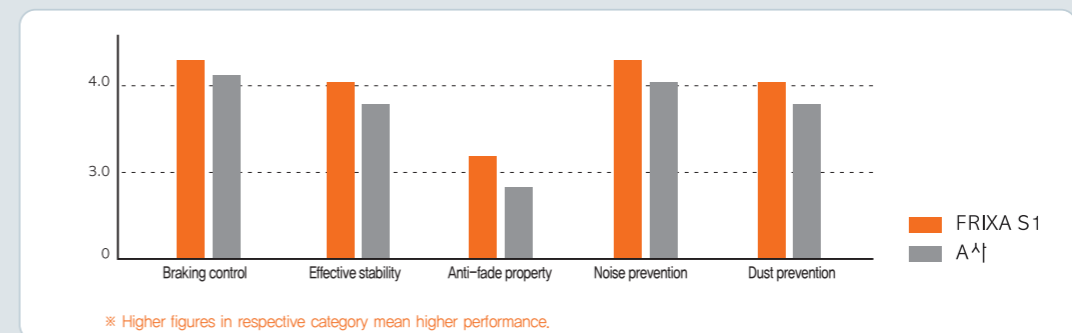

We guarantee accurate and safe braking We manufacture and provide the products of all kinds of cars at home and from passenger car to light truck The products of FRIXA has low noise in all vehicles

HYUNDAI BRAKE FRONT PAD

FRIXA CODE	PARTS NO.		SP NO.	WVA NO.	FMSI NO.	HP NO.	TRW	REPRESENTATIVE MODEL	INTERCHANGEABLE
FPH22	58160-5K300		SP1207					MIGHTY 06MY	MIGHTY 06MY(06.04~) COUNTY 06(06.04~)
FPH23	58101-3MA00 58101-3MA01		SP1246		D1384-8400			GENESIS	GENESIS(08.01~)
FPH24	58101-2MA10							GENESIS COUPE	COUPE18'19'(BREMBO TYPE)(08.10~)
FPH25	58101-3SA20							YF SONATA	YF SONATA15'(09.09~) SPORTAGE R(10.03~) TUCSON IX 2WD(09.08~)
FPH26	58101-3XA00							AVANTE MD	AVANTE MD
FPH27	58101-1RA00		SP1399					ACCENT 11MY	ACCENT 11MY
FPHXDF	58101-2D000 58101-2DA00 58101-2DA10		SP1147			HP0020		AVANTE XD	AVANTE XD1.5(00.03~04.04)
FPHXGF	58115-391S0		SP1190			HP0015		GRANDEUR XG	GRANDEUR XG2.5(3.0(15')(98.09~02.06) GRANDEUR XG2.7 TAXI(15')(98.09~02.06)
FPHXGN	48130-21A00 4813A-21100 58101-39A60 58101-3BA01 58101-3BA02	58101-3BA20 58101-3FA00 58101-3FA10 58101-3FA20	SP1161	23726 23727 23728 24167	D1013-7917	HP0016	GDB3257	NEW GRANDEUR XG	GRANDEUR XG2.5(3.0(16')(02.07~05.05) EQUUS3.0(3.5(16')(01.07~03.09) EQUUS4.5(01.02~04.05) OPIRUS(03.02~06.05) RODIUS(04.06~) NEW TERRACAN(04.08~06.10) TRAJET XG(16')(02.07~07.05)

HYUNDAI BRAKE REAR PAD

FRIXA CODE	PARTS NO.		SP NO.	WVA NO.	FMSI NO.	HP NO.	TRW	REPRESENTATIVE MODEL	INTERCHANGEABLE
FPH01R	44060-02E90 44060-08E91 44060-61E90 44060-61E94 44060-65E90 44060-79E91 44060-86E90 44060-90E90 44060-D3591 58215-291S0	58215-2D300 58302-28A00 58302-28A01 58302-29A00 58302-29A10 58302-2DA00 58302-2DA10 58302-2FA00 58302-2FA10 DD06061E25	SP1062	21553 21554 21555	D323-7146 D323-7283 D429-7146 D464-7344	HP0021	GDB1010 GDB1450 GDB3170 GDB3368	AVANTE R	ELANTRA(88.02~94.07) TIBURON,TURBULENCE(96.04~01.08) TUSCANI2.0(2.7(01.09~08.07) AVANTE(95.03~00.04) AVANTE XD 1.5(00.03~04.04) NEW AVANTE XD 1.6(03.05~06.09) CERATO(03.10~05.02)
FPH02NR	43022-SD4000 43022-SD4010 43022-SD4020 43022-SG9000 58201-33A00	58201-33A02 58215-341S0 58302-34A00 GBP90300 GBP90304	SP1074	20029 20078 20079	D342-7236 D1262-7236	HP0005	GDB994	SONATA R	SONATA II/III(93.06~98.03) MARCIA(95.03~98.05)
FPH04R	58215-375A0 58302-M2A00 58302-M2A01 58302-M2A10		SP1054-R	23608 23609 23610		HP0011		NEW GRANDEUR2.0 R	NEW GRANDEUR2.0(2.5(95.04~98.02) NEW GRANDEUR2.5(95.04~98.01) CARSTA(99.05~03.03) SANTAMO(96.01~02.12)
FPH05R	58215-375A0		SP1082			HP0013		NEW GRANDEUR3.0 R	NEW GRANDEUR2.5(98.01~98.09) NEW GRANDEUR3.0(3.5(95.04~98.09) DYNASTY(99.10~05.08) EQUUS3.0(3.5(15')(99.04~02.05)
FPH09R	58302-2BA00 58302-2BA20 58302-4A000	58302-4AA00 58302-4AA10	SP1178	24464 24488 24489 24490	D1297-8414			STAREX R	STAREX(NEW)(04.01~07.04) NEW SANTAFE(06MY)(05.11~)

HYUNDAI BRAKE REAR PAD

FRIXA CODE	PARTS NO.		SP NO.	WVA NO.	FMSI NO.	HP NO.	TRW	REPRESENTATIVE MODEL	INTERCHANGEABLE
FPH12R	58302-H1A00 58302-H1A10		SP1098	23813 24201 24202		HP0023	GDB3296	TERRACAN R	TERRACAN(01.01~04.07) NEW TERRACAN(04.08~06.10)
FPH17R	58302-2EA31 58302-2KA00 58302-2KA10	58302-3FA01 58302-3KA31 58302-3KA52	SP1239		D1313-8428 D1445-8428 D1446-8428 D1544-8428			NF TRANSFORM R	NF TRANSFORM(07.12~) OPIRUS(NEW)(06.06~)
FPH19R	58302-3JA00 58302-3JA50 58302-4DA00	58302-4DE00 58302-4HA00 58302-4HA50	SP1192	24599 24600 24686	D1302-8418		GDB3449	VERACRUZ R	VERACRUZ(06.05~) GRAND STREX(07.05~) GRAND CARNIVAL(05.07~)
FPH24R	58302-2MA10							GENESIS COUPE R	COUPE18'19'(BREMBO TYPE)(08.10~)
FPH25R	58302-1GA00 58302-1GE00 58302-1HA00 58302-1HA10		SP1187	24320 24321 24322	D1157-8267		GDB3421	YF SONATA	YF SONATA(09.09~) K7(09.12~) / I-30(07.06~) FORTE(08.08~) TUCSON IX(09.08~)
FPH26R	58302-3XA30	58302-1RA30	SP1401					AVANTE MD R	AVANTE MD(10.08~) / ACCENT 11MY R
FPHXGR	58215-383S0 58302-1CA10 58302-1FA00 58302-1FE00 58302-26A00 58302-26A30 58302-2EA00 58302-2EA30 58302-2GA00 58302-2HA00 58302-38A00 58302-38A10 58302-38A11	58302-38A20 58302-38A30 58302-39A40 58302-3AA00 58302-3AA20 58302-3CA10 58302-3CA20 58302-3FA00 58302-3KA10 58302-3KA30 58302-3KA40 58302-3KA60 58302-3LA20	SP1117	23543 23544 23545	D813-7688 D863-7688	HP0008	GDB3282 GDB3284 GDB3298 GDB3413	GRANDEUR XG R	EF SONATA(98.04~00.12) NEW EF SONATA(01.01~04.08) GRANDEUR XG, NEW GRANDEUR XG(98.04~05.05) / LOTZE(04.11~07.11) NF SONATA(04.09~07.09) OPIRUS(03.02~06.05) OPTIMA/OPTIMA REGAL(02.08~05.10) GRANDEUR TG(05.06~07.11) TUCSON(04.03~) / LAVITA(00.04~) NEW SPORTAGE(04.08~) TRAJET XG(99.09~07.05) SANTAFE 2WD/4WD(00.02~05.11) AVANTE XD2.0(00.03~04.04) AVANTE 06MY(06.06~)

KIA BRAKE FRONT PAD

FRIXA CODE	PARTS NO.		SP NO.	WVA NO.	FMSI NO.	HP NO.	TRW	REPRESENTATIVE MODEL	INTERCHANGEABLE
FPK01	B5Y8-3323Z D001-3328Z D012-3328Z DA19-3328Z DA19-3328ZA	KK150-33100 KK150-3323Z KK150-3328Z KK325-3328Z	SP1049	21355 21356 21357	D402-7291	HP1001	GDB773	PRIDE	PRIDE/BETA(86.~99.)
FPK01N	58101-1G000 58101-1GA00	58101-1GE00 58101-1JA10	SP1186	24317 24318 24319	D1156-8266		GDB3420	PRIDE(NEW)	PRIDE 05MY(05.08~) VERNA 05MY(05.08~)
FPK02	0K900-49230 GA2949280 GA9749280 GA9749280A	GGY8-3328Z GGY8-3328Z9A 0K9004923Z	SP1051	21360 20794 21168 21666	D317-7169		GDB1036	CONCORD	CONCORD CAPITAL
FPK03	0K20A-3323Z 0K239-3323Z 0K240-3323Z 0K243-3323Z 0K2A2-3323Z 0K2A3-3323Z	0K2A4-3323Z 0K2X3-3323Z 0K2Y1-3323Z 0K2Y2-3323Z 0K2Y3-3323Z 0K2Y3-3323ZA	SP1063	23384 23385 23386	D649-7529	HP1003 HP1021	GDB3096	SEPHIA	SEPHIA I/II(92.~00.06) SHUMA(97.03~99.)
FPK04	0K2A-3323Z 0K9A0-3328Z 0K9A3-3328Z	0K9A6-3328Z 0K9A7-3328Z 0K9Y6-3328Z	SP1079-F	23450 23451		HP1007	GDB3173	CREDOS	CREDOS(95.03~98.03)

PRODUCT LIST

CHEVROLET (GM-DAEWOO)_ BRAKE FRONT PAD

FRIXA CODE	PARTS NO.	SP NO.	WVA NO.	FMSI NO.	HP NO.	TRW	REPRESENTATIVE MODEL	INTERCHANGEABLE									
FPD01	52210-70B00	55210-05E20	SP1050	23061		HP2001	GDB3108	TICO	TICO(91.~00.09)								
	55200-61880	55220-50850															
	55201-78810-000	4BP365908264															
	55201-78820-000																
FPD02	90297552	96101972S	SP1055	20939	D378-7267	HP2003	GDB199	LEMANS	LEMANS(86.~97.) ROYALE PRINCE(~92.) BROUGHAM(93.~95.)								
	96100972	96133030S															
	961019725	96133555S															
FPD03	90297552	96101972S	SP1055	20939	D378-7267	HP2003	GDB199	ESPERO1.5	ESPERO1.5(90.10~96.12) CIELO(94.~97.) NEXIA(95.~97.)								
	96100972	96133030S															
	961019725	96133555S															
FPD05	11046952012	S4512002	SP1078	21190	D796-7666	HP2004	GDB951	ESPERO2.0	ESPERO2.0(TEVESE) PRINCE(TEVESE)								
	11046152	S4512001															
FPD06	96245178	S4510011	SP1077			HP2005	GDB7583	NEW PRINCE	NEW PRINCE(92.~97.) LANOS DOHC(96.~03.) BROUGHAM(NEW)(95.~97.)								
	96281937	S4510014															
	96475176	S4510018															
	S4510001	S4511001															
	S4510005	S4511004															
	S4510008	S4511006															
	S4510009	S4511009															
	FPD07	45022-SA0999HE								55200-70860	SP1059	20731	D177-7104 7104-D281	HP2013	GDB254	DAMAS	DAMAS(92.~03.08) DAMAS II(03.09~) LABO(92.~02.)
		45022-SA0N50								55200-70861							
45022-SA0N51		55200-70862															
55101-80800000		55210-56A50															
55104-80600000		55210-70820															
55104-80800000		55210-78460															
55104-80810000		55210-M84500															
55200-56850		91144333															
55200-56851		93742538															
55200-60B50		GBP90264															
55200-70820		GBP90269															
FPD08		96245178	96391891	SP1102	23234	7667-D797 D797-7668	HP2006	GDB3216	LEGANZA	LEGANZA(97.12~02.04) NUBIRA DOHC(97.~99.) NUBIRA II(99.~03.)							
		96253367	96446742														
	96253382	96495164															
	96253383	S4510009N															
	96349059																
FPD09	96273708	96446176	SP1086	23241	8433-D1321	HP2002	GDB3195	LANOS	LANOS SOHC(96.~03.) MATIZ I/II/III(98.~)								
	96281945	S4510004															
	96288629	S4510017															
	96316582	S4510021															
FPD10	96349059	96446762	SP1103	24062		HP2008	GDB3345	MAGNUS	MAGNUS(99.12~02.02) MAGNUS L6 2.0(02.03~06.01) REZZO(00.01~07.02)								
	96349060	96495164															
	96394977	96495227															
	96446742	96496765															
FPD12	96418874	96449288	SP1159	23234	D902-7779 D1035-7779	HP2012	GDB3171	LACETTI	LACETTI(02.11~) GENTRA X(14")(07.10~)								
	96405129	96534655															
	96405130	55200-85Z00															
FPD13	94566892		SP1158	23974	D1269-8385	HP2011	GDB3330	KALOS	KALOS(02.05~) GENTRA(05.09~) GENTRA X(13")(07.10~) NUBIRA SOCH(97.02~02.10)								
	96534653																
FPD14	96475026		SP1193		D1031-7936			TOSCA	TOSCA(06.02~) MAGNUS L6 2.5(02.12~06.01)								
	96475027																
	96952179																

CHEVROLET (GM-DAEWOO)_ BRAKE FRONT PAD

FRIXA CODE	PARTS NO.	SP NO.	WVA NO.	FMSI NO.	HP NO.	TRW	REPRESENTATIVE MODEL	INTERCHANGEABLE	
FPD15	45022-S10A00	45022-SLRG01	SP1076-F	21651	D503-7382	HP2010	GDB995	ARCADIA	ARCADIA(94.02~99.)
	45022-S10A02	45022-SLRG02							
	45022-S10G00	45022-SM5A00							
	45022-S10G01	45022-SN7G50							
	45022-S10G02	45022-SP0E00							
	45022-S30A00	45022-SS0G00							
	45022-S30A02	45022-SS0G01							
	45022-S30A50	45022-SS0G02							
	45022-SA1AE20	45022-ST7R00							
	45022-SL0600	45022-ST7R01							
	45022-SL0G00	96329471							
45022-SL0G01	GBP90329								
45022-SL0G02									
FPD16	96626069		SP1204	24510	8381-D1264		GDB1715	WINSTORM	WINSTORM(06.06~)
	96626070								
	D966226070								
FPD17	13301208		SP1362					LACETTI PREMIERE	LACETTI PREMIERE(08.12~)
FPD18	P94564512							MATIZ CREATIVE	MATIZ CREATIVE

CHEVROLET (GM-DAEWOO)_ BRAKE REAR PAD

FRIXA CODE	PARTS NO.	SP NO.	WVA NO.	FMSI NO.	HP NO.	TRW	REPRESENTATIVE MODEL	INTERCHANGEABLE
FPD08R	96245179	SP1114	23237	D724-7591 D724-7669	HP2007	GDB3172	LEGANZA R	LEGANZA(97.~03.) NUBIRA(97.~03.)
	96253368							
	96253369							
	96391892							
	AW346513							
	S4521001							
S5421002								
S4521006								
FPD10R	55500-86Z00	SP1252	23994	D1030-7935	HP2009	GDB3346	MAGNUS R	MAGNUS(99.12~06.01) TOSCA(06.02~)
	96475028							
	96496763							
	96496766							
FPD12NR	55500-85Z10	SP1257		D1315-7939			LACETTI NR	LACETTI NEW
FPD12R	55500-85Z00	SP1160	24071	D1036-7939	HP1024	GDB3348	LACETTI R	LACETTI(02.11~)
	94696764							
	96405131							
FPD16R	19149904	SP1205	24498	D1275-8391		GDB1716	WINSTORM R	
	96626075							
	96626076							
	D966226076							

SSANGYONG_ BRAKE FRONT PAD

FRIXA CODE	PARTS NO.	SP NO.	WVA NO.	FMSI NO.	HP NO.	TRW	REPRESENTATIVE MODEL	INTERCHANGEABLE
FPY01	66142-03021	SP1083		D092	HP4003	GDB7614	ISTANA	ISTANA(95.~03.06)
FPY02	48130-05000 48130-05010 48130-05011 48130-05012	SP1065	21725 21756 21757	D449-7329 D462-7342 D469-7349 D485-7342 D700-7329 D747-7329 D887-7765	HP4001	GDB3101 GDB3169 GDB3211 GDB3256 GDB3283 GDB3365 GDB7521 GDB895	MUSSO	MUSSO, MUSSO SPORTS(97.12~08.08) KORANDO FAMILY(88.10~99.10) NEW KORANDO(96.07~05.12)
FPY03	48130-08050 48130-08150 48130-08152	SP1144	21725 21726 21727		HP4004		REXTON	REXTON(01.~03.12)
FPY04	48150-110A2	SP1088			HP4005		CHAIRMAN	CHAIRMAN NEW CHAIRMAN(97.07~08.03)
FPY06	48130-08250 48130-08260 48130-090A0 48130-091A0	SP1171	23569 23570 23571	D864-7739	HP4007	GDB3244	KYRON	KYRON(05.06~) NEW REXTON(04.01~) ACTYON(05.10~)

SSANGYONG_ BRAKE REAR PAD

FRIXA CODE	PARTS NO.	SP NO.	WVA NO.	FMSI NO.	HP NO.	TRW	REPRESENTATIVE MODEL	INTERCHANGEABLE
FPY03R	48413-05100 48413-05102 48413-08050 48413-08051 48413-090A0 48413-090A1	SP1151	23673 23674 23675 24050 24051 24052		HP4002	GDB3382	REXTON R	MUSSO(97.12~08.08) NEW KORANDO(96.07~05.12) KYRON(05.06~) ACTYON(05.10~)
FPY04R	48450-110A0	SP1089					CHAIRMAN R	REXTON(01.~) CHAIRMAN
FPY05R	48413-091A0 48413-091A1 48413-21A10 58302-3EU00 58302-4DU00	SP1173	23931 23932 23933 23993	D954-7853		GDB3413	RODIUS R	NEW CHAIRMAN(97.07~08.03) RODIUS(04.06~) KYRON IRS(05.06~) ACTYON IRS(05.10~)

RENAULT SAMSUNG_ BRAKE FRONT PAD

FRIXA CODE	PARTS NO.	SP NO.	WVA NO.	FMSI NO.	HP NO.	TRW	REPRESENTATIVE MODEL	INTERCHANGEABLE	
FPS01	41060-2Y090 41060-2Y091 41060-2Y991 41060-40U90 41060-40U92 41060-5Y790 41060-88E87 41060-88E90 41060-88E91	41060-88E94 41060-89E90 41060-89E91 41060-8J090 41060-AU091 41060-ZG225 48111-51110K0 48311-51110K0	SP1107-F	21561 21562 21633	D430-7832 D653-7318 D815-7318 D815-7783 D815-7832	HP3001	GDB1003	SM-5	518/520/525(98.~05.03)
FPS02	41060-4M490 41060-6N091 41060-6N0X1 41060-95FOA 48111-31100K0 AY040NS072	AY040NS073 AY040NS084 AY040NS096 AY040NS100 AY040NS108	SP1156	24647 24648 24649	D1193-8311	HP3004	GDB7043	SM-3	SM-3(02.~09.06)
FPS03	48111-52100K0		SP1183					SM-7	NEW SM-5(05.04~) SM-7(05.04~)
FPS04	41060-0013R 41060-0V790 41060-CC090	41060-CC093 41060-EB325	SP1249	23698 23699 24497	D888-7766 D888-8221	HP3005		QM-5	QM-5(07.12~)
FPS05	41 06 083 64R							NEW SM-3	NEW SM-3
FPS06	41060-1605R							NEW SM-5	NEW SM-5

RENAULT SAMSUNG_ BRAKE REAR PAD

FRIXA CODE	PARTS NO.	SP NO.	WVA NO.	FMSI NO.	HP NO.	TRW	REPRESENTATIVE MODEL	INTERCHANGEABLE	
FPS01NR	44060-4U092 44060-6Y390 44060-6Y391 44060-AU090 44060-AU091 48311-52001K0 55800-60J00	55800-60J10 F1Y12643Z F1YA2343Z F1YA2348Z F1YA2643Z F1YA2648	SP1163	24039 24040 24041	D900-7777 D1008-7912 D1008-8313	HP3003		SM-5(NEW) R	SM-5 02MY(02.07~05.03)
FPS01R	48311-51110K0 44060-0N690 44060-4U090 44060-6E390	44060-73C91 44060-75C90 44060-7E690	SP1107-R	21713 21714 21715	D540-7533	HP3002	GDB1172	SM-5 R	518/520/525(~02.06)
FPS03R	44060-8H385 44060-AL585 44060-AL586 44060-AM485 44060-CB10J 44060-EG00J	44060-EG00K 44060-EG085 48311-52000K0 D4060-8H385 D4060-EG50C	SP1184	23814 23871 23872 24088	D1393-8501 D1415-8405 D905-7784		GDB3294	SM-7 R	NEW SM-5(05.04~) SM-7(05.04~)
FPS05R	44 06 020 70R							NEW SM-3 R	NEW SM-3

FOREIGN VEHICLES_ BRAKE PAD

FRIXA CODE	REMARK (SP NO.)	PARTS NO.	VVA NO.	FMSI NO.	TRW	MAKER	REPRESENTATIVE MODEL	INTERCHANGEABLE	
FPE026	FRONT (PAD)	04491-87506-000				DAIHATSU	HIJET	S100C,S110C,S100P,S110P(94.01~98.12)	
FPE027	FRONT (PAD)	26296-TC001 26296-TC010 26296-TC020 26296-TC030 26296-TC040 26296-TC050			GDB1420 GDB3215	SUBARU SUZUKI	SAMBAR SWIFT CULTUS	TT1,TT2,TV1,TV2,TW1,TW2(99.01~04.08) SA310A(97.01~00.06) SF413M(97.01~01.05) SF416(97.01~00.02) SF310AA,SF310MA(98.04~01.01) SF413MA(98.04~01.05)	
FPE028	FRONT (PAD)	45022-S2K-000 45022-S3A-000 45022-SC2-000 45022-SC2-010 45022-SC2-020 45022-SC2-040 45022-SC2-050 45022-SD5-010 45022-SD5-020 45022-SD5-040 45022-SD5-050 45022-SD5-060 45022-SF4-000 45022-SF4-010 45022-SF4-020 45022-SF4-060 45022-SFA-000	45022-SJ6-000 45022-SJ6-010 45022-SJ6-020 45022-SJ6-030 45022-SJ6-040 45022-SJ6-050 45022-SJ6-325 45022-SJ6-J00 45022-SJ6-J01 45022-SJ6-J02 45022-SD5-000 45022-ST5-000 45022-ST5-010 45022-ST5-020			HONDA	LIFE ACTY VAMOS	JA4(97.05~98.10) JB1,JB2(98.10~03.09) JB5,JB6(03.09~) HA1,HA2,HH1,HH2(88.05~90.02) HH3,HH4,HA3(90.02~99.06) HA4,HA5(90.02~99.07) HA6,HA7(99.05~) HH5,HH6(99.06~) HM1,HM2(99.05~03.04) HJ1,HJ2,HM3,HM4(03.04~)	
FPE029	FRONT (PAD)	26296-KG000 41060-4A00B 41060-4A0A2 41060-4A0A3 55810-56A01 55810-58J00 55810-60J00	55810-74G00 55810-74G03 55810-76G00 55810-76G01 55810-76G02 55810-76G03 AY040-KE121	23507 23508	D1225-8344	SUZUKI	ALTO KEI WAGON R	HA12S,HA12V(98.10~00.12) HA22S(98.10~02.04) / HA23S(00.12~04.09) HA23V(00.12~05.01) / HE21S(02.05~05.01) HA24S(04.09~09.12) / HA24V(05.01~09.12) HN11S(98.10~01.04) HN21S,22S(98.10~03.04) HN22S(01.04~) MC11S/12S(98.10~00.12) MC21S/22S/MF21S(98.10~03.12) MH21S(03.09~05.09)	
FPE030	FRONT (PAD)	06450-S0A-J00 06450-S0K-J11 06450-S7S-000 06450-S87-A00 45022-S00-G10 45022-S0A-J02 45022-S10-A00 45022-S10-A01 45022-S10-A02 45022-S10-G00 45022-S10-G01 45022-S10-G02 06450-S2H-J00 45022-S30-A00 45022-S30-A01 45022-S30-A02 45022-S47-000 45022-S47-010 45022-S47-020 45022-S70-000 45022-S70-010 45022-S70-020 45022-S87-A01 45022-SL0-030	45022-SL0-G02 45022-SL0-J02 45022-SL0-N10 45022-SLR-G01 45022-SM5-305 45022-SM5-525 45022-SM5-A00 45022-SN7-G50 45022-SPO-010 45022-SPO-506 45022-SPO-526 45022-SPO-A00 45022-SS0-A00 45022-SS0-A02 45022-SS0-G00 45022-SS0-G01 45022-SS0-G02 45022-ST7-R00 45022-ST7-R01 45022-ST7-R02 45022-SX0-J00 45022-SX0-J01 45022-SX0-J02	21651 21652 21653	D503-7382	GDB1062 GDB3177 GDB3188 GDB3196 GDB995	HONDA	ACCORD ODYSSEY STEP WAGON	CE7(96.01~98.12) CC7,CE8(93.01~98.12) CF4,CF5(97.08~02.10) CL3(00.06~02.10) CE2(94.01~97.10) CD9(95.01~98.12) CG4(98.01~02.10) CB8,CB9,CE1(90.01~98.12) CD6(93.09~97.09) CE9(96.01~98.12) CH1(98.10~02.12) CG2(98.01~03.06) CD7,CD8(94.02~96.12) CF2(96.08~97.09) CF6,CF7(97.10~06.02) CH9,CL2(98.12~06.02) RA1,RA2(94.09~97.09) RA3,RA4(97.07~99.12) RA5(97.10~00.01) RF1,RF2(96.04~01.04) RF3,RF4(01.04~05.10) RF5,RF6,RF7,RF8(03.06~05.05)

FOREIGN VEHICLES_ BRAKE PAD

FRIXA CODE	REMARK (SP NO.)	PARTS NO.	VVA NO.	FMSI NO.	TRW	MAKER	REPRESENTATIVE MODEL	INTERCHANGEABLE	
FPE031	FRONT (PAD)	8-97078409 8-97078409-2 8-97172427 8-97226103 8-97318894 8-97368980-0 8-97368980				ISUZU	ELF	NKR69,WKR69(93.07~99.04) NHR69,NHS69,NKR(99.05~02.05) NHR69M,NHR69E,NHR69MA, NHR69(02.06~04.05) NHR69EV(03.08~) / NHR69(N)(04.05~) NKR69EA, NHS69EA, NKR81EA, NKR81LAR(02.6~) / VKR66K(96.11~02.05) NHS69EA(03.08~06.12) / NHS69A(04.05~06.12) NKR58,NKR63,NKR66,VKR66K,NPR66, NKR66,NKS66(93.07~99.04) NKS71(93.07~) / NKR71(95.05~04.99) NKR71,NPR71(04.99~) NKR81(02.04~) / NKS81(02.06~) NKS81A(04.05~06.12) / NKR72(00.02~)	
FPE035	FRONT (PAD)	06430-S0A-J00 06430-S0K-J01 06430-S0N-J00 06430-S2A-000 06430-S2X-J00 06430-S3N-J00 06430-S5A-J00 06430-S6D-000 06430-S7A-J00 06430-S7S-000 06430-S9A-000 06430-SED-000 06430-SED-E50 06430-SEP-A00 43022-S2A-000 43022-S3N-000 43022-S5A-J00 43022-S6D-000 43022-S7S-010 43022-S9A-000 43022-S9A-010 43022-S9A-E00 43022-SD4-906 43022-SD4-930 43022-SED-000 43022-SED-E50 43022-SEP-A00 43022-SG0-000 43022-SG0-010 43022-SG0-020 43022-SJF-000 43022-SJF-E00 43022-SL5-000 43022-SL5-505	43022-SL5-525 43022-SM4-505 43022-SM4-515 43022-SM4-525 43022-SM4-950 43022-SM4-G00 43022-SN7-000 43022-SPO-000 43022-SPO-010 43022-SPO-020 43022-SPO-305 43022-SPO-E02 43022-SPO-E03 43022-SS0-000 43022-SV4-000 43022-SV4-010 43022-SV4-020 43022-SV4-030 43022-SV4-A00 43022-SV4-A02 43022-SV4-A20 43022-SV4-A21 43022-SV4-A22 43022-SV4-G00 43022-SV4-G02 43022-SV4-G20 43022-SV4-G22 43022-SX0-A50 43022-SX0-A52 43022-SY8-A00 43022-SY8-A01 43022-TL0-G50	21719 21720 21721	D1086-7418 D365-7256 D537-7418	GDB1063 GDB3154 GDB3175 GDB3191 GDB3269 GDB3438 GDB774	HONDA	ODYSSEY STEP WAGON	RA1,RA2(94.09~97.09) RA3,RA4(97.07~99.12) RA5(97.10~00.01) RA6,RA7(99.12~03.10) RA8,RA9(00.01~03.10) RF1,RF2(96.04~01.04) RF3,RF4(01.04~05.10) RF5,RF6,RF7,RF8(03.06~05.05)
FPE036	FRONT (PAD)	55210-60FA1 55810-60FA0 55810-60FA1 55810-60FA3				SUZUKI	WAGON R ALTO CERVO	CT21S,CV21S(95.10~98.10) CT51S,CV51S(97.04~98.10) HA11S,HB11S,HC11V, HD11V(94.11~98.09) CN22S,CP22S(97.05~98.06)	
FPE037	FRONT (PAD)	04465-52190 04465-52240 04465-52270 04465-B1360				GDB3460	TOYOTA	VITZ VERTA YARIS RACTIS	NCP91(05.02~) SCP92(05.11~) NCP93(06.01~) SCP100,NCP100,NCP105(05.10~)

FOREIGN VEHICLES_ BRAKE PAD

FOREIGN VEHICLES_ BRAKE PAD

Table with columns: FRIXA CODE, REMARK (SP NO.), PARTS NO., VVA NO., FMSI NO., TRW, MAKER, REPRESENTATIVE MODEL, INTERCHANGEABLE. Includes rows for FPE064, FPE087, FPE088, FPE089, FPE090, FPE091, FPE092, FPE096, FPE097, FPE098.

Table with columns: FRIXA CODE, REMARK (SP NO.), PARTS NO., VVA NO., FMSI NO., TRW, MAKER, REPRESENTATIVE MODEL, INTERCHANGEABLE. Includes rows for FPE099, FPE100, FPE101, FPE102, FPE103, FPE104.

PRODUCT LIST

FOREIGN VEHICLES_ BRAKE PAD

FRIXA CODE	REMARK (SP NO.)	PARTS NO.	VVA NO.	FMSI NO.	TRW	MAKER	REPRESENTATIVE MODEL	INTERCHANGEABLE
FPE105	FRONT (PAD)	2121-3501090	20660		GDB265	LADA	NIVA 2121	COSSACK(78.~96.) NIVA (VAZ 2121)1.6/1.7(76.~00.) NIVA (VAZ 2121)1.9D/1.9D JR,LX(88.~93.) TAIGA(77.~00.)
	(SP1168)							
FPE106	FRONT (PAD)	2101-3501089 2101-35011090 2101-3501090 2101-3501210A 2101-350109001 4208932	20166			LADA	WHA 2101-2107	NOVA - KALINA (VAZ 2105/2107)(81.~00.) RIVA ESTATE (VAZ 2101/2102/2103/2106)(73.~85.) TOSCANA (VAZ 2107)(83.~92.)
	(SP1199)							
FPE107	FRONT (SP1200)				GDB851	GAZ	VOLGA	GAZELLE
FPE108	FRONT / REAR (PAD)	0004217391 0044201720 0004237110 9014210110 0024204120 9024210110 0024204220 2D0698151A 0034201720	29076	D949-7848	GDB1288	MERCEDES BENZ	SPRINTER	SPRINTER (904)(96.~03.)
	(SP1245)							
FPE109	FRONT (PAD)	4B0698151E 4B0698151AB 4B0698151K 12759808 4B0698151N	20676 23106 23107	D840-7711 D840-7715 D840-7764	GDB1049	AUDI	A4	
	(SP2001)					VOLKSWA GEN	GOLF	
FPE110	REAR (PAD)	4B0698151AB 4D0698451D 1A0698451E 8E0698451 1E0698451C 8E0698451A 1H0615415 8E0698451B 4B0698451 8E0698451D 4B0698451B 8E0698451E 4B0698451E	20261 20960 23554	D340-7234 D340-7234 D894-7773 D1017-7920 D1023-7773 D1112-8216	GDB1196	AUDI	A4	A3, A6
	(SP2029)					PEUGEOT	405	
FLE01	REAR (SHOE ASS'Y)	77 01 201 758 77 01 203 979 77 01 205 720 77 01 206 962 77 01 208 111 7701-203-79 7701-205-20 7701-206-62			GS8534	RENAULT	CLIO	BB0,CB0(98.03~01.05) BB0L,BB0P,CB0L,CB0P(00.02~06.02) BB07,CB07,BB08,CB08,BB0T,BB1D,CB0T, CB1D(01.06~06.02) SB0A(98.03~) SB0F,SB07(01.06~)
						PEUGEOT	LOGAN	L90
							106 206 306	

FRIXA S1 PAD_ Premium

MAKER	REPRESENTATIVE MODEL	FRIXA CODE	SET/BOX	INTERCHANGEABLE	YEAR			
HYUNDAI (FRONT)	AVANTE	S1H01	8	AVANTE	(95.03~00.04)			
				ELANTRA 1.5	(88.02~94.07)			
				EXCEL	(85.02~94.07)			
				ACCENT	(94.04~99.10)			
				STELLAR	(83.07~97.01)			
				SCOUPE	(90.02~95.05)			
				CLICK	(02.05~07.05)			
				VERNA	(99.06~05.07)			
				AVANTE XD	S1HXDF	8	AVANTE XD1.5	(00.03~04.04)
				EF SONATA	S1H02F	8	EF SONATA	(98.04~00.12)
				NEW EF SONATA	(01.01~03.08)			
				OPTIMA 1.8/2.0	(98.06~02.08)			
				GRANDEUR XG2.0	(98.09~05.11)			
				AVANTE XD2.0	(00.03~04.04)			
				LAVITA	(00.04~02.03)			
	NF SONATA	S1H02NF	8	NFSONATA(15"WHEEL)	(04.09~07.09)			
				NF TRANSFORM(15"WHEEL)	(07.10~)			
				NEW EF SONATA	(03.09~04.08)			
				OPTIMA REGAL	(02.09~05.10)			
				LOTZE(15"WHEEL)	(05.11~07.11)			
				LOTZE INNOVATION(15"WHEEL)	(07.12~)			
				TUSCANI 2.0	(01.09~08.07)			
				SOUL	(08.09~)			
	TUCSON			TUCSON	(04.03~)			
			NEW SPORTAGE	(04.08~)				
GRANDEUR XG	S1HXGF	8	GRANDEUR XG2.5/3.0(15"WHEEL)	(98.09~02.06)				
			GRANDEUR XG2.7TAXI(15"WHEEL)	(98.09~02.06)				
SANTAFE			SANTAFE 2WD	(00.02~05.11)				
			TRAJET XG(15"WHEEL)	(99.09~07.05)				
			EQUUS 3.0/3.5(15"WHEEL)	(99.04~02.05)				
NEW GRANDEUR XG	S1HXGN	8	GRANDEUR XG2.5/3.0(16"WHEEL)	(02.07~05.05)				
			EQUUS 3.0/3.5(16"WHEEL)	(01.07~03.09)				
			EQUUS 4.5	(01.02~04.05)				
			OPIRUS	(03.02~06.05)				
NEW GRANDEUR XG	S1HXGN	8	RODIUS	(04.06~)				
			NEW TERRACAN	(04.08~06.10)				
			TRAJET XG(16"WHEEL)	(02.07~07.05)				
STAREX	S1H09	8	STAREX	(97.03~02.09)				
			LIBERO	(97.03~03.11)				
STAREX(NEW)	S1H09N	8	STREX(NEW)	(02.10~07.05)				
			LIBERO	(03.12~07.12)				
SANTAFE4WD	S1H11N	8	SANTAFE 4WD	(00.02~05.11)				
			NEW GRANDEUR XG3.0(12"DISC)	(02.07~05.05)				
GRANDEUR TG	S1H17	8	NF SONATA2.0/2.4(16"WHEEL)	(04.09~07.09)				
			NF TRANSFORM(16"WHEEL)	(07.10~)				
			LOTZE(16"WHEEL)	(05.11~07.11)				
			LOTZE INNOVATION(16"WHEEL)	(07.12~)				
			OPIRUS(NEW)	(06.06~)				

FRIXA S1 PAD_ Premium

MAKER	REPRESENTATIVE MODEL	FRIXA CODE	SET/BOX	INTERCHANGEABLE	YEAR	
	NEW SANTAFE	S1H18	8	NEW SANTAFE(06MY)	(05.11~)	
				SORENTO R	(09.04~)	
	VERACRUZ	S1H19	8	VERACRUZ	(06.05~)	
	i-30	S1H20	8	i-30	(07.06~)	
				FORTE	(08.08~)	
	NEW AVANTE	S1H21	8	AVANTE 06MY	(06.06~)	
	GENESIS	S1H23	8	GENESIS	(08.01~)	
	YF SONATA	S1H25	8	YF SONATA15*	(09.09~)	
				TUCSON IX 2WD	(09.08~)	
AVANTE MD	S1H26	8	AVANTE MD	(10.10~)		
HYUNDAI (REAR)	AVANTE XD R	S1H01R	8	ELANTRA	(88.02~94.07)	
				TIBURON, TURBULENCE	(96.04~01.08)	
				TUSCANI 2.0/2.7	(01.09~08.07)	
				AVANTE	(95.03~00.04)	
				AVANTE XD1.5	(00.03~04.04)	
				NEW AVANTE XD1.6	(03.05~06.09)	
				CERATO	(03.10~05.02)	
	GRANDEUR TG R	S1HXGR	8	EF SONATA	(98.04~00.12)	
				NEW EFSONATA	(01.01~04.08)	
				GRANDEUR XG,NEW GRANDEUR XG	(98.04~05.05)	
				NF SONATA	(04.09~07.09)	
				LOTZE	(04.11~07.11)	
				OPIRUS	(03.02~06.05)	
				OPTIMA / OPTIMA REGAL	(02.08~05.10)	
				GRANDEUR TG	(05.06~07.11)	
				TUCSON	(04.03~)	
				NEW SPORTAGE	(04.08~)	
				TRAJET XG	(99.09~07.05)	
				SANTAFE 2WD/4WD	(00.02~05.11)	
				LAVITA	(00.04~)	
				AVANTE XD2.0	(00.03~04.04)	
				AVANTE 06MY	(06.06~)	
	NEW SANTAFE R	S1H09R	8	STAREX(NEW)	(04.01~07.04)	
				NEW SANTAFE(06MY)	(05.11~)	
	NF TRANSFORM R	S1H17R	8	NF TRANSFORM	(07.12~)	
				OPIRUS(NEW)	(06.06~)	
				LOTZE INNOVATION	(07.12~)	
	GRAND STAREX R	S1H19R	8	VERACRUZ	(06.05~)	
				GRAND STAREX	(07.05~)	
				GRAND CARNIVAL	(05.07~)	
	YF SONATA R	S1H25R	8	YF SONATA	(09.09~)	
				K7	(09.12~)	
				FORTE	(08.08~)	
				I-30	(07.06~)	
				TUCSON IX	(09.08~)	
	AVANTE MD R	S1H26R	8	AVANTE MD	(10.10~)	
	KIA (FRONT)	NEW PRIDE	S1K01N	8	PRIDE 05MY	(05.08~)
					VERNA 05MY	(05.08~)

FRIXA S1 PAD_ Premium

MAKER	REPRESENTATIVE MODEL	FRIXA CODE	SET/BOX	INTERCHANGEABLE	YEAR
KIA (FRONT)	CARENS	S1K04N	8	CREDOS II	(98.04~00.07)
				RIO SF1.5(14"WHEEL)	(02.06~05.04)
				SPECTRA	(01.02~03.07)
	CARNIVAL II	S1K10N	8	NEW PREGIO	(98.06~03.12)
	CARENS II	S1K14N	8		
	SORENTO	S1K15	8	SORENTO	(02.02~09.03)
	CERATO 15"	S1K17N	8		
	MORNING	S1K20	8	MORNING	(04.01~)
	GRAND STAREX	S1K21	8	NEW CARNIVAL(16"WHEEL)	(06.02~)
	GRAND CARNIVAL	S1K22	8	GRAND CARNIVAL(17"WHEEL)	(05.07~)
	NEW CARENS	S1K25	8		
KIA (REAR)	CARENS R	S1K04R	8	CREDOS I / II	(95.03~00.07)
				SEPHIA II	(95.~99.)
				SHUMA	(97.~99.)
				SPECTRA	(01.02~)
				CARENS I / II	(99.06~06.03)
SORENTO R	S1K15R	8	SORENTO	(02.01~)	
K5 R	S1K27R	8	K5	(10.05~)	
DAEWOO	MATIZ	S1D09	8	LANOS SOHC	(96.~03.)
				MATIZ I / II / III	(98.~)
	MAGNUS	S1D10	8	MAGNUS	(99.12~02.02)
				MAGNUS L6 2.0	(02.03~06.01)
				REZZO	(00.01~07.02)
	LACETTI	S1D12	8		
	TOSCA	S1D14	8	TOSCA	(06.02~)
MAGNUS L6 2.5				(02.12~06.01)	
WINSTORM	S1D16	8			
SSANGYONG	REXTON	S1Y03	8	REXTON	(01.~03.12)
	REXTON R	S1Y03R	8		
	KYRON	S1Y06	8		
SAMSUNG	SM-5 R	S1S01R	8		
	SM-5(NEW) R	S1S01NR	8		
	SM-3	S1S02	8	SM-3	(02. ~09.06)
	SM-7	S1S03	8	NEW SM-5	(05.04~)
				SM-7	(05.04~)
SM-7 R	S1S03R	8	NEW SM-5	(05.04~)	
			SM-7	(05.04~)	

HYUNDAI BRAKE SHOE ASS'Y_ REAR

FRIXA CODE	PARTS NO.	SP NO.	WVA NO.	FMSI NO.	HP NO.	TRW	REPRESENTATIVE MODEL	INTERCHANGEABLE
FLH01	58305-17A00	SA062			HS0002		AVANTE	AVANTE(95.03~00.04)
	58305-28A00				HS0004		AVANTE XD(00.03~04.04)	
	58305-28A70						NEW AVANTE XD(04.05~06.05)	
	58305-28E00						AVANTE 06MY(06.06~)	
	58305-29A00						VERNA(NEW)(02.08~05.07)	
	58305-29A10						ELANTRA(88.02~94.07)	
	58305-2DA10						TIBURON(96.04~01.08)	
FLH012	58305-24000	SA046			HS0001		EXCEL	EXCEL(85.02~94.07)
	58305-24020						SCOUPE(90.02~95.02)	
	58305-24A00						VERNA(OLD)(99.06~02.07)	
	58305-24A20							
	58305-24A30							
58305-25A00								
FLH013	58305-22A00	SA047			HS0003		ACCENT	ACCENT(94.04~99.10)
	58305-22A01							
FLH02	58305-34A10	SA048			HS0005		SONATA	SONATA I/II/III(88.06~98.04)
	58305-33A00				HS0006		STELLAR(83.07~97.01)	
FLH02F	58305-38A00	SA111			HS0007		EF SONATA	EF SONATA(98.04~04.08)
	58305-3CA00						LAVITA(00.04~02.03)	
FLH06	48250-01000	SA072-GR			HS0012		NEW GRACE	NEW GRACE(94.05~03.12)
	48330-05000						GALLOPER(99.01~02.01)	
	58315-44020S						MUSSO(02.03~08.08)	
	66142-03019						ISTANA(95.~03.06)	
							NEW KORANDO(96.07~05.12)	
							REXTON(OLD/NEW)(01.~)	
		KYRON(05.06~)						
		ACTYON(05.10~)						
		KORANDO FAMILY(88.10~95.10)						
FLH07	58305-4BA00	SA072-PO			HS0011		PORTER	PORTER(96.03~03.12)
	58315-44000S							
	58325-44000							
FLH09	58305-4AA00	SA099			HS0009		STAREX	STAREX(97.03~02.09)
	58305-4AA30						GALLOPER II(02.01~03.12)	
	58305-M2A10							
	MB950065							
	SB000102							
FLH10	58305-02500	SA096			HS0008		ATOZ	ATOZ(97.09~02.12)
	58305-02A00						VISTO(98.02~04.01)	
	58305-02A10							
FLH11	58305-47A00	SA100			HS0013		LIBERO	LIBERO(97.03~03.11)
FLH12	58305-1CA00	SA133					CLICK	CLICK(02.05~07.05)
	58305-1CA10							
FLH13	58305-4AA20	SA130			HS0010		STREX(NEW)	STREX(NEW)(02.12~07.05)
FLH14	58305-4FA01	SA135					PORTER II(Low DECK)	PORTER II(Low DECK)(04.01~)
							BONGO III(Low DECK)(04.01~)	

KIA BRAKE SHOE ASS'Y_ REAR

FRIXA CODE	PARTS NO.	SP NO.	WVA NO.	FMSI NO.	HP NO.	TRW	REPRESENTATIVE MODEL	INTERCHANGEABLE	
FLK01	KK150-26310 KK150-2638ZA	SA049			HS1001		PRIDE	PRIDE/BETA(86.~99.)	
FLK02	KK150-2638Z	SA052					CONCORD	CONCORD(87.~96.01)	
	OK917-2638Z							CAPITAL(89.~96.01)	
FLK03	OK23N-2638Z	SA053			HS1006		SEPHIA	SEPHIA(NEW)II(97.03~00.06)	
FLK04	OK2FA-2638Z	SA079					CARENS	CREDOS I/II(95.03~00.07)	
	OK2N1-2638Z							OK9A6-2623ZA	CARENS I/II(99.06~06.03)
	OK9A0-2623Z							OK9A6-2638Z	
FLK05	KK370-2638Z	SA067			HS1016		AVELLA	AVELLA	
FLK07	OK011-2638Z	SA070					SPORTAGE	SPORTAGE(93.06~99.02)	
	OK011-3323Z								
	OK0Y1-2638Z								
FLK08	OK70Y-2638Z	SA044					BESTA	BESTA(87.07~97.04)	
	OK710-2638Z							TOPIC(87.~91.)	
	OK710-2638ZA							BONGO(NEW)(94.~94.04)	
								PORTER II(HIGH DECK)(04.01~)	
								BONGO III(HIGH DECK)(04.01~)	
								BONGO III VAN(12SEAT)(04.01~)	
								BONGO III 1.4TON(04.01~)	
FLK082	OK71E-2638Z	S02A26310A	SA045				WIDE BONGO	WIDE BONGO(94.01~97.06)	
	OK71F-3328Z	S02A49380						FRONTIER1.3TON(NEW)(01.~03.12)	
	OK756-2638Z	S08526310						FRONTIER1.4TON(NEW)(01.~03.12)	
	OK756-2638ZA	S08526330							
	44060-HC625	S08549380							
	58350-4EA00	S0YA2638Z							
FLK10	OK72A-2638Z	SA044			HS1011		PREGIO	PREGIO(95.10~98.05)	
FLK10N	OK79A-2638Z	SA127			HS1013		PREGIO GRAND	NEW PREGIO(98.06~03.02)	
								BONGO III VAN(15SEAT)(04.01~)	
FLK13	OK552-2638Z	SA112			HS1012		CARNIVAL	CARNIVAL(98.01~99.01)	
FLK13N	OK56A-2638Z	SA020					CARNIVAL(NEW)	CARNIVAL II(99.01~03.12)	
	OK56A-2638ZA							TRAJET XG(99.12~01.08)	
	58305-3AA00							TRAJET XG(01.09~03.12)	
FLK14	01823-2638Z	SA015					CERES	CERES(83.~94.)	
	01823-2638ZA							BONGO(OLD)(~94.)	
	01823-26310B								
FLK14N	OK68A-3328Z	SA019					CERES(NEW)	CERES(NEW)(94.~96.)	
FLK15	OK30A-2628Z	SA137					RIO	RIO(99.11~02.05)	
	OK30B-2628Z								
FLK15N	OK30B-2628Z	SA134					RIO SF	RIO SF(02.06~05.04)	
	58315-FDA00								
	58315-FDA01								
FLK16	OK045-2638Z	SA018					ROCSTA R2	ROCSTA R2(92.~97.)	
	AA301-26310							SPORTAGE GRAND(00.~02.)	
								RETONA(00.~02.)	
FLK17	K611-2638Z						FRONTIER1.3	FRONTIER1.3TON(OLD)(99.06~01.)	
								FRONTIER1.4TON(OLD)(99.06~01.)	
FLK18	58305-1GA00	SA153					PRIDE(NEW)	PRIDE 05MY(05.08~)	
								VERNA 05MY(05.08~)	
FLK19	58350-07A00	SA154					MORNING	MORNING(04.01~)	
FLKT02	OK201-2638Z	SA051					TOWNER	TOWNER(TRUCK/VAN)(96.~02.)	
	OK2N1-2638Z							CONCORD(87.~96.01)	
	OK900-2638Z							CAPITAL(89.~96.01)	
	AA100-26310							SEPHIA(92.~97.02)	

CHEVROET (GM-DAEWOO)_ BRAKE SHOE ASS'Y_ REAR

FRIXA CODE	PARTS NO.	SP NO.	WVA NO.	FMSI NO.	HP NO.	TRW	REPRESENTATIVE MODEL	INTERCHANGEABLE
FLD01	53200-70800-000 53200-70810-000 53201-70B00-000 53201-70B10-000 96268686 96316620	SA050 SA086			HS2001 HS2002	GS8645	TICO	TICO(91.~00,09) MATIZ(98.~)
FLD02	S4520001 S4520002	SA010			HS2006		PRINCE	PRINCE(92.~97.) ROYAL PRINCE(~92.) BROUGHAM(93.~97.)
FLD03	90272780 96226111	SA055-OLD			HS2004		LEMANS	LEMANS(86.~97.) ESPERO(OLD)(90,10~94.)
FLD04	96226110 NP1441 96241979 NP1464 96241980 S4520003 96300315 S4520005 96300316 S4520006 96430417	SA055-NEW			HS2005		ESPERO(NEW)	ESPERO(NEW)(94.~96,12) CIERO(94.~97.) NEXIA(95.~97.) LANOS(96.~03.) NUBIRA I/II(97.~03.)
FLD07	53200-85800	SA059			HS2003		DAMAS	DAMAS, DAMAS II(92.~) LABO(92.~02.)
FLD08	96245180 96253300	SA102			HS2007		LEGANZA	LEGANZA(97,04~02,04) NUBIRA DOHC(97.~99.)
FLD09	96349066 96394977	SA103			HS2008		REZZO	REZZO(00,01~07,02)
FLD10	83740251 93740252 93740525 96473228 96473229 S4520007 S4520008	SA129			HS2009		KALOS	KALOS(02,05~)
FLD11	96446745	SA119					MAGNUS	MAGNUS(99,12~02,02)

RENAULT SAMSUNG_ BRAKE SHOE ASS'Y_ REAR

FRIXA CODE	PARTS NO.	SP NO.	WVA NO.	FMSI NO.	HP NO.	TRW	REPRESENTATIVE MODEL	INTERCHANGEABLE
FLS01	48430-31010K0	SA131					SM-3	SM-3(02.~)



FRIXA BRAKE SYSTEM

DISC BRAKE PAD

HYUNDAI	(FRONT)	P. 52 ~
	(REAR)	P. 69 ~
KIA	(FRONT)	P. 75 ~
	(REAR)	P. 90 ~
CHEVROLET	(FRONT)	P. 94 ~
	(REAR)	P. 102 ~
SSANGYONG	(FRONT)	P. 105 ~
	(REAR)	P. 107 ~
SAMSUNG	(FRONT)	P. 109 ~
	(REAR)	P. 111 ~
FOREIGN VEHICLES		P. 113 ~

FRIXA BRAKE SYSTEM
DISC BRAKE PAD
We guarantee accurate and safe braking

FRIXA CODE	MAKER	HYUNDAI	PART NUMBER		58101-1CA00	
FPH01	REPRESENTATIVE MODEL	AVANTE	INTERCHANGEABLE		AVANTE, ELANTRA 1.5, EXCEL, ACCENT, STELLA, SCOUPE, CLICK, VERNA	
	PO	SP	WVA	FMSI	HP	TRW
	FRONT	SP1047	21012	D404-7293	HP0004	GDB3331

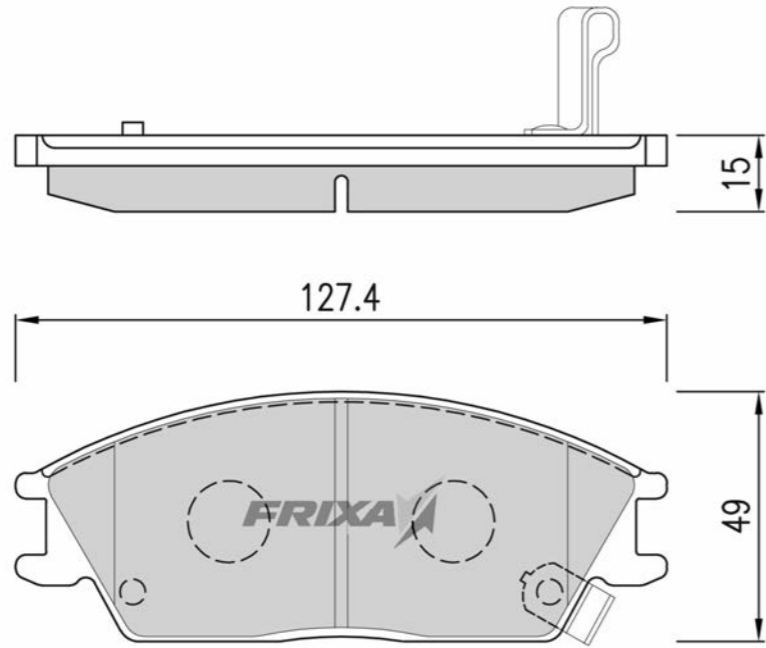

FRIXA CODE	MAKER	HYUNDAI	PART NUMBER		58101-28A00	
FPH02	REPRESENTATIVE MODEL	SONATA	INTERCHANGEABLE		SONATA, ELANTRA1.6/1.8, AVANTE TOURING, TIBURON, SONATA II, MARCIA	
	PO	SP	WVA	FMSI	HP	TRW
	FRONT	SP1048	21725	D449-7329	HP0003	GDB3101

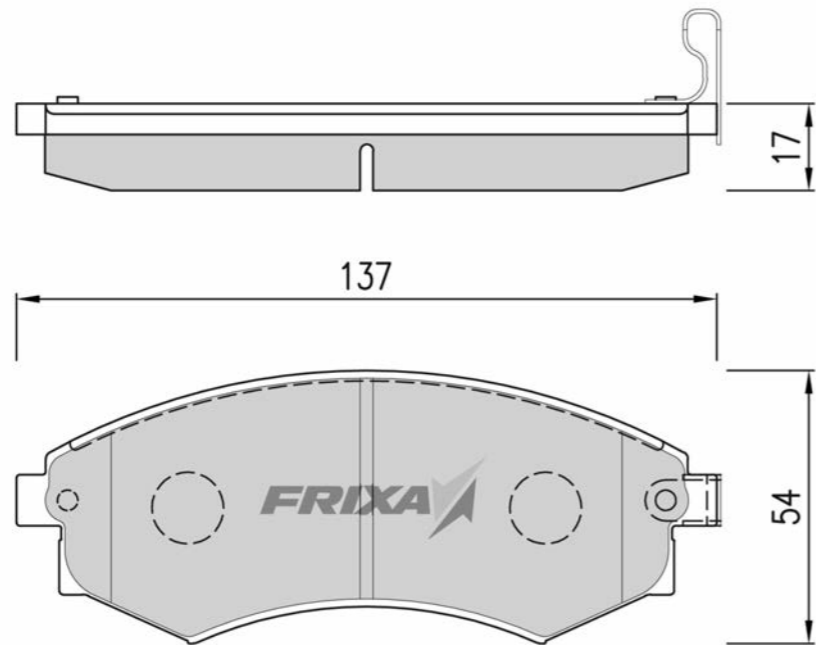

MAKER	HYUNDAI	PART NUMBER		58101-34A21		FRIXA CODE
REPRESENTATIVE MODEL	SONATA III	INTERCHANGEABLE		SONATA III(R.SPRING Type) MARCIA		FPH02S
PO	SP	WVA	FMSI	HP	TRW	
FRONT	SP1048	21725	D449-7329	HP0006	GDB3101	

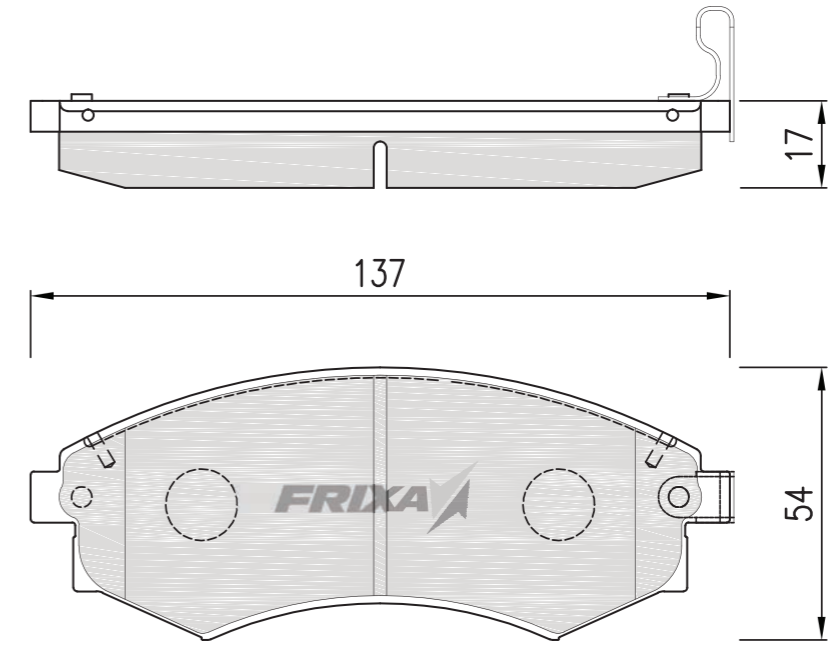

MAKER	HYUNDAI	PART NUMBER		58101-17A00		FRIXA CODE
REPRESENTATIVE MODEL	EF SONATA	INTERCHANGEABLE		EF SONATA, NEW EF SONATA, OPTIMA1.8/2.0 GRANDEUR XG 2.0, AVANTE XD 2.0, LAVITA, SOUL		FPH02F
PO	SP	WVA	FMSI	HP	TRW	
FRONT	SP1111	21725	D449-7329	HP0007	GDB3101	

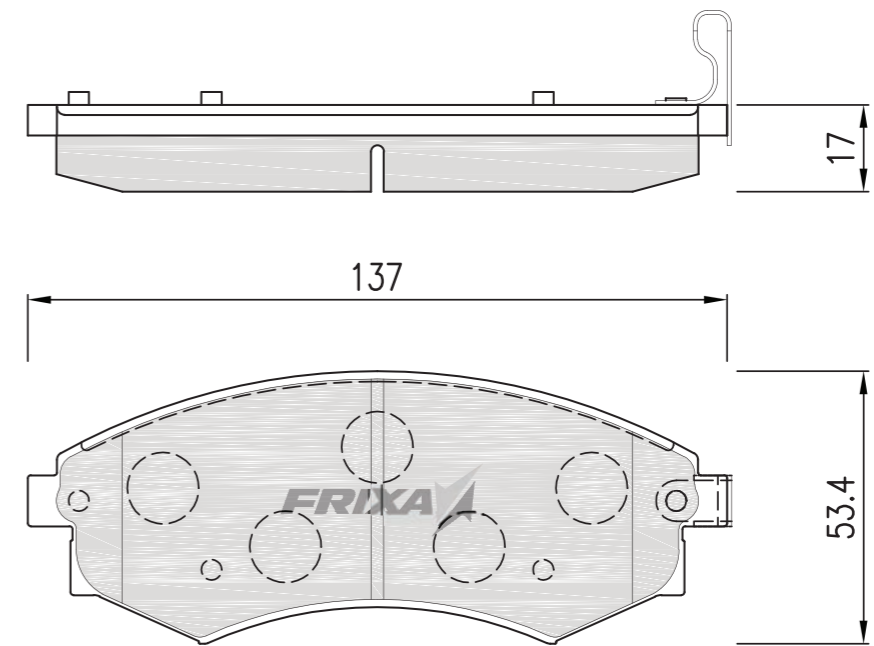

DISC BRAKE PAD

BRAKE SHOE ASSEMBLY

BRAKE LINING

DISC BRAKE PAD

BRAKE SHOE ASSEMBLY

BRAKE LINING

FRIXA CODE	MAKER	HYUNDAI	PART NUMBER		58101-1FA00	
FPH02NF	REPRESENTATIVE MODEL	NF SONATA	INTERCHANGEABLE		NF SONATA, NEW EF SONATA, OPTIMA REGAL, SOUL NF TRANSFORM, LOTZE, INNOVATION, TUSCANI 2.0	
	PO	SP	WVA	FMSI	HP	TRW
	FRONT	SP1155	23891	8306-D1125	HP0009	GDB3352

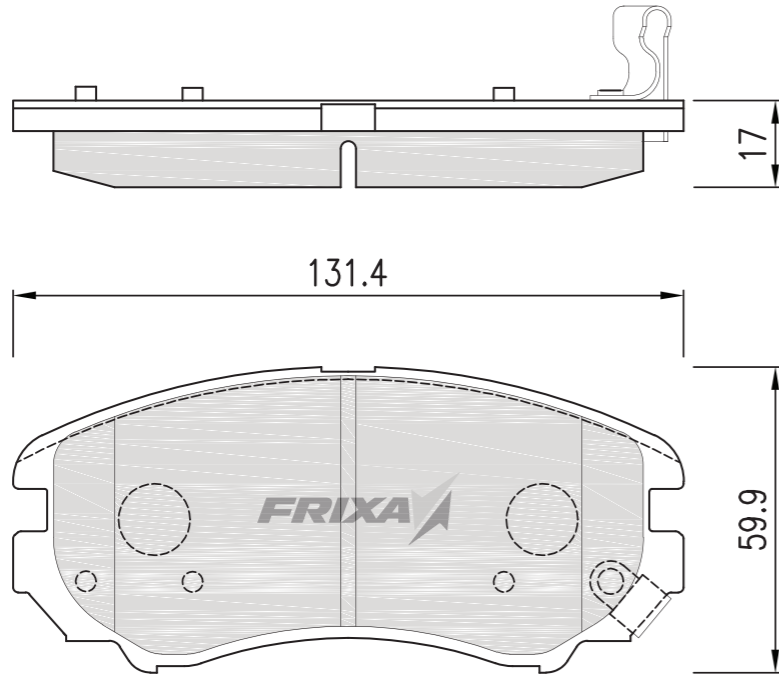

FRIXA CODE	MAKER	HYUNDAI	PART NUMBER		58101-M2A00	
FPH04	REPRESENTATIVE MODEL	NEW GRANDEUR 2.0	INTERCHANGEABLE		NEW GRANDEUR 2.0/2.5 CARSTAR, SANTAMO	
	PO	SP	WVA	FMSI	HP	TRW
	FRONT	SP1054-F			HP0010	

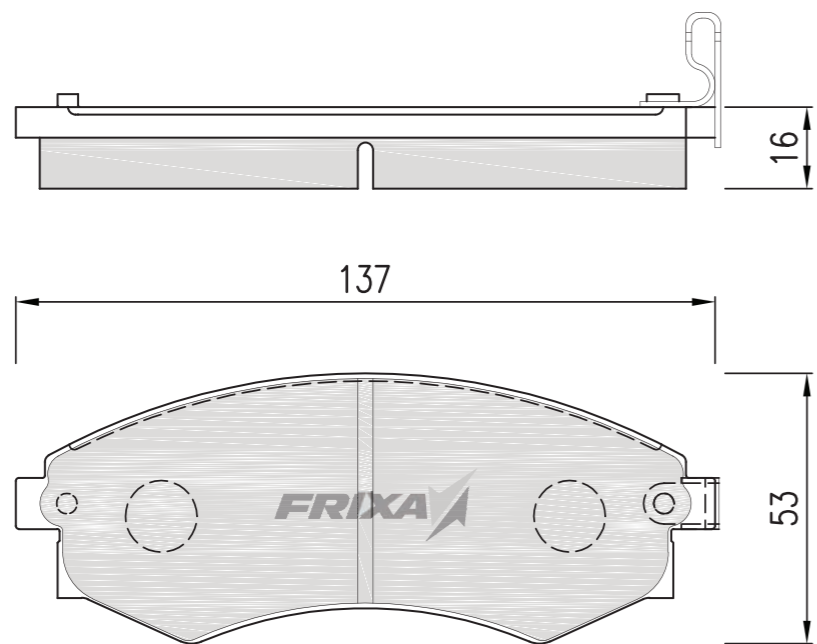

MAKER	HYUNDAI	PART NUMBER		58101-37A10		FRIXA CODE
REPRESENTATIVE MODEL	NEW GRANDEUR 3.0	INTERCHANGEABLE		NEW GRANDEUR 3.0/3.5 DYNASTY		FPH05
PO	SP	WVA	FMSI	HP	TRW	
FRONT	SP1081			HP0012		

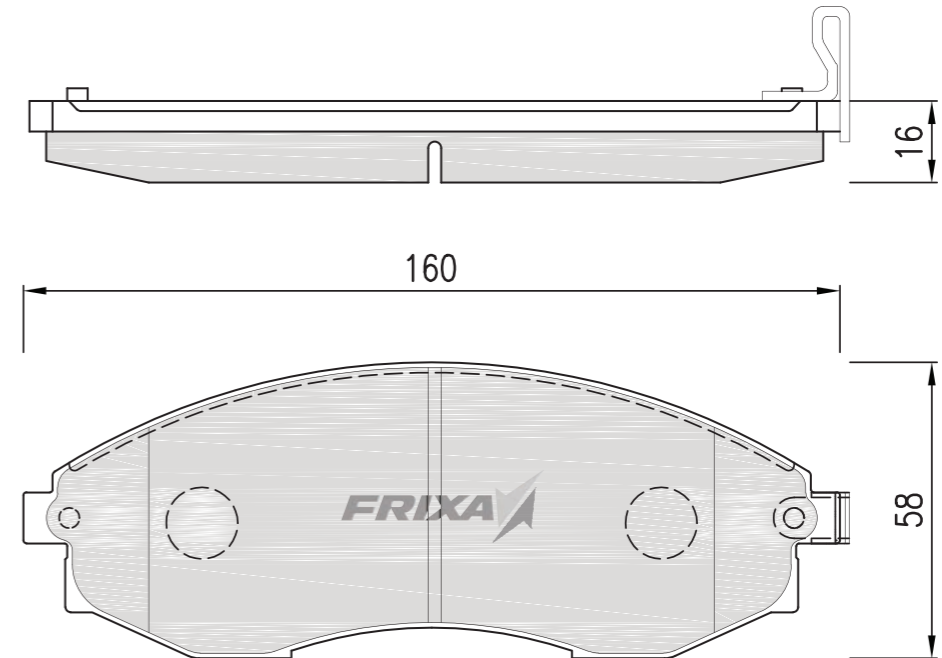

MAKER	HYUNDAI	PART NUMBER		58101-43A00		FRIXA CODE
REPRESENTATIVE MODEL	NEW GRACE	INTERCHANGEABLE		NEW GRACE, PORTER NEW		FPH06
PO	SP	WVA	FMSI	HP	TRW	
FRONT	SP1072	23081	D1137-8247	HP0019	GDB3089	

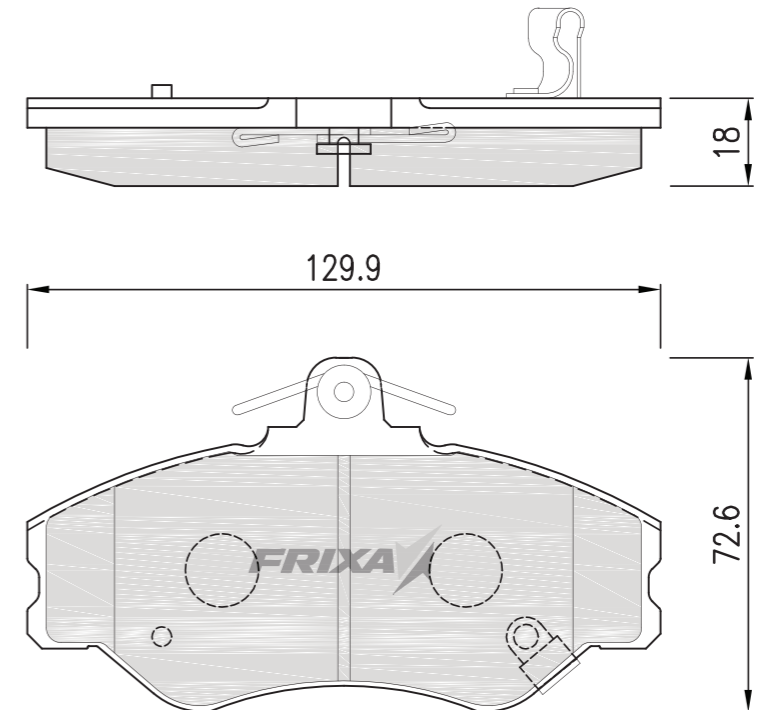

DISC BRAKE PAD

BRAKE SHOE ASSEMBLY

BRAKE LINING

DISC BRAKE PAD

BRAKE SHOE ASSEMBLY

BRAKE LINING

FRIXA CODE	MAKER	HYUNDAI	PART NUMBER		58101-M1A00	
FPH07	REPRESENTATIVE MODEL	GALLOPER	INTERCHANGEABLE		GALLOPER, GALLOPER INNOVATION	
	PO	SP	WVA	FMSI	HP	TRW
	FRONT	SP1053	23518		HP0017	

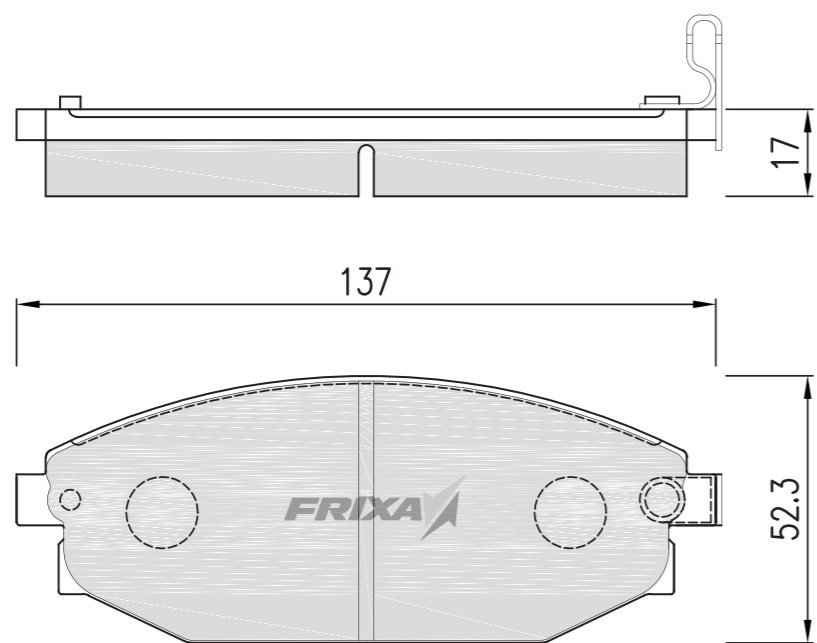

FRIXA CODE	MAKER	HYUNDAI	PART NUMBER		58101-45A00	
FPH08	REPRESENTATIVE MODEL	MIGHTY	INTERCHANGEABLE		MIGHTY 2.5TON, MIGHTY 3.5TON, COUNTY	
	PO	SP	WVA	FMSI	HP	TRW
	FRONT	SP1080			HP0028	

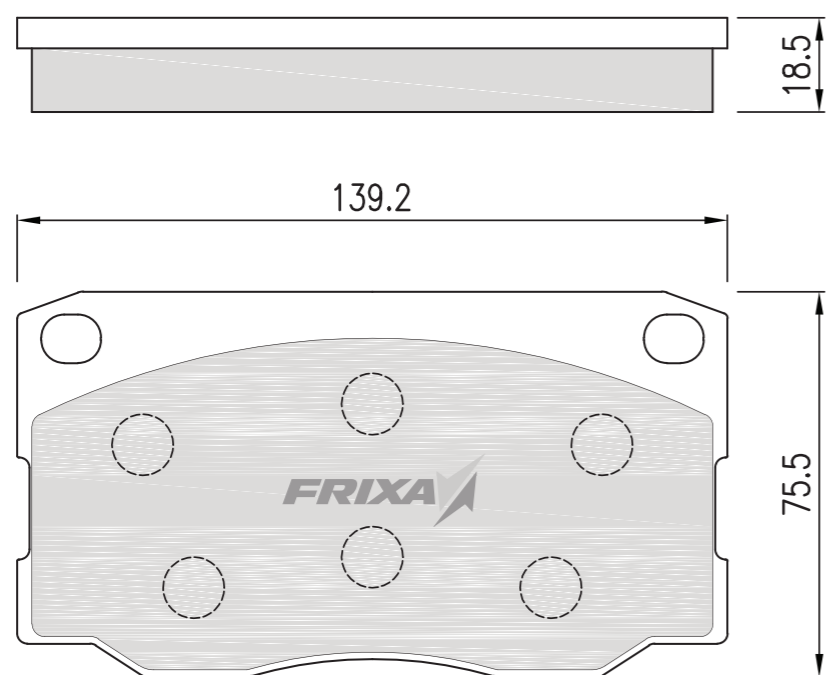

MAKER	HYUNDAI	PART NUMBER		58101-4AA00		FRIXA CODE
REPRESENTATIVE MODEL	STAREX	INTERCHANGEABLE		STAREX, LIBERO		FPH09
PO	SP	WVA	FMSI	HP	TRW	
FRONT	SP1099	23536		HP0018	GDB3201	

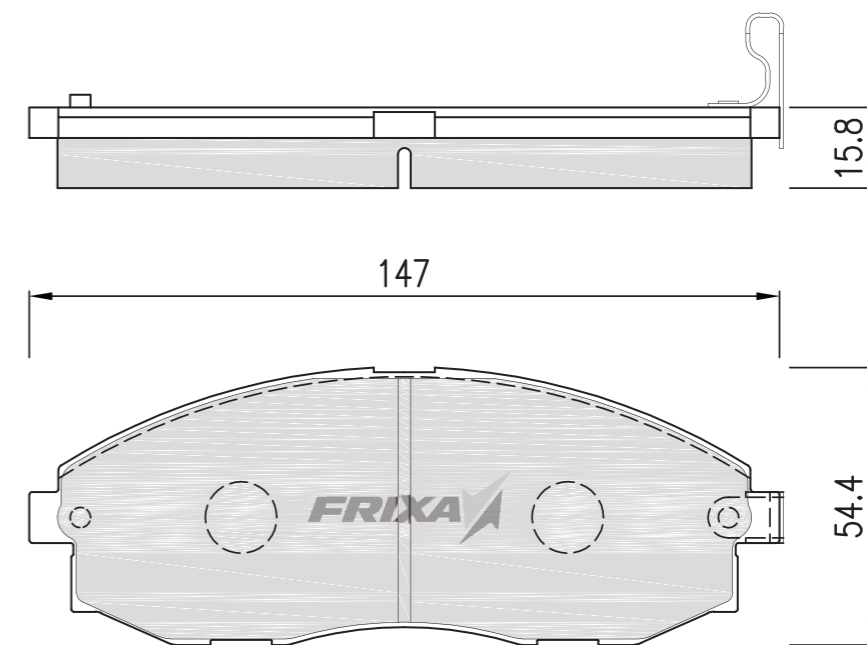

MAKER	HYUNDAI	PART NUMBER		58101-2AA26		FRIXA CODE
REPRESENTATIVE MODEL	STAREX NEW	INTERCHANGEABLE		STAREX (NEW), LIBERO		FPH09N
PO	SP	WVA	FMSI	HP	TRW	
FRONT	SP1157	23569	D864-7739	HP0024	GDB3244	

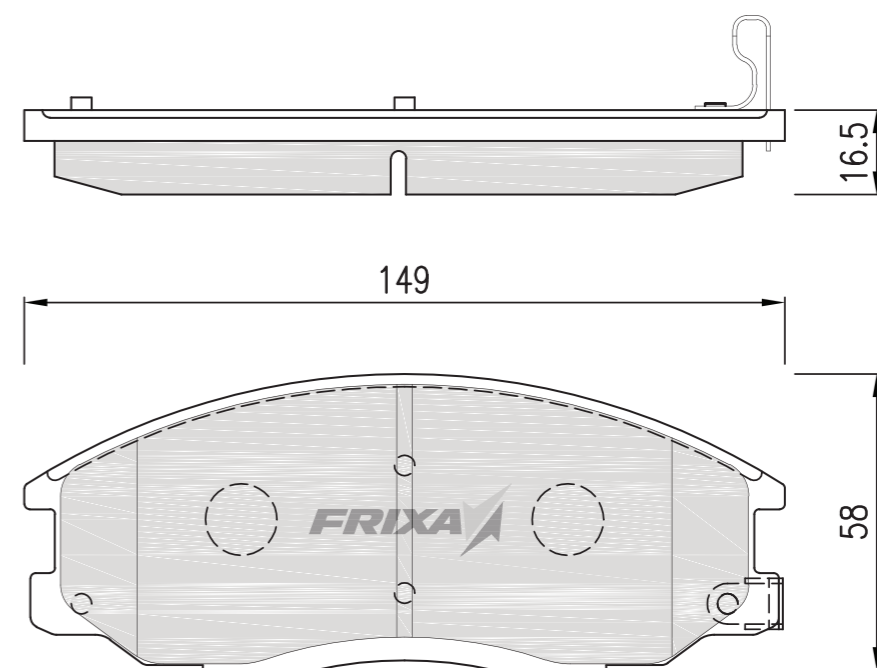

DISC BRAKE PAD

BRAKE SHOE ASSEMBLY

BRAKE LINING

DISC BRAKE PAD

BRAKE SHOE ASSEMBLY

BRAKE LINING

FRIXA CODE	MAKER	HYUNDAI	PART NUMBER		58101-02A00	
FPH10	REPRESENTATIVE MODEL	ATOZ	INTERCHANGEABLE		ATOZ, VISTO	
	PO	SP	WVA	FMSI	HP	TRW
	FRONT	SP1096	23238	D1148-8225	HP0001	GDB3165

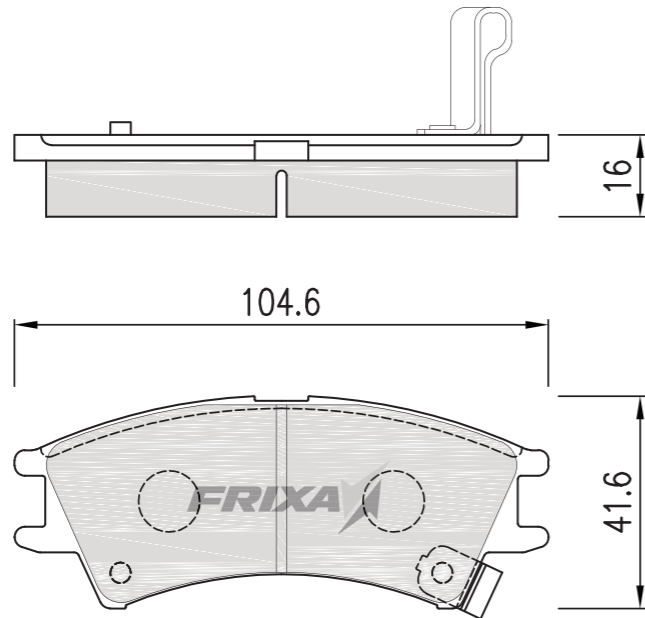

FRIXA CODE	MAKER	HYUNDAI	PART NUMBER		58101-02A10	
FPH10N	REPRESENTATIVE MODEL	ATOZ NEW	INTERCHANGEABLE		ATOZ NEW, VISTO NEW	
	PO	SP	WVA	FMSI	HP	TRW
	FRONT	SP1149	24277	D1142-8253	HP0002	GDB3377

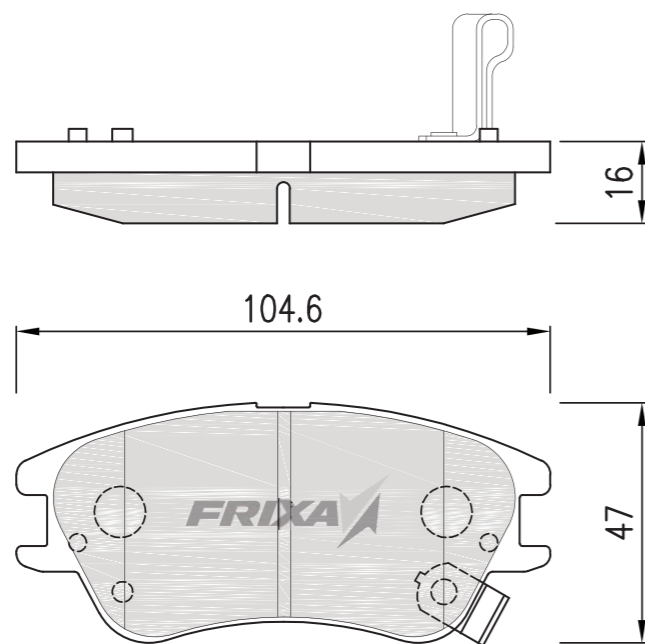

MAKER	HYUNDAI	PART NUMBER		OK52Y-3323Z		FRIXA CODE
REPRESENTATIVE MODEL	SANTAFE	INTERCHANGEABLE		SANTAFE 2WD, TRAGET XG (15"WHEEL) EQUUS3.0/3.5 (15"WHEEL)		FPH11
PO	SP	WVA	FMSI	HP	TRW	
FRONT	SP1115	23569	D864-7739	HP0014	GDB3244	

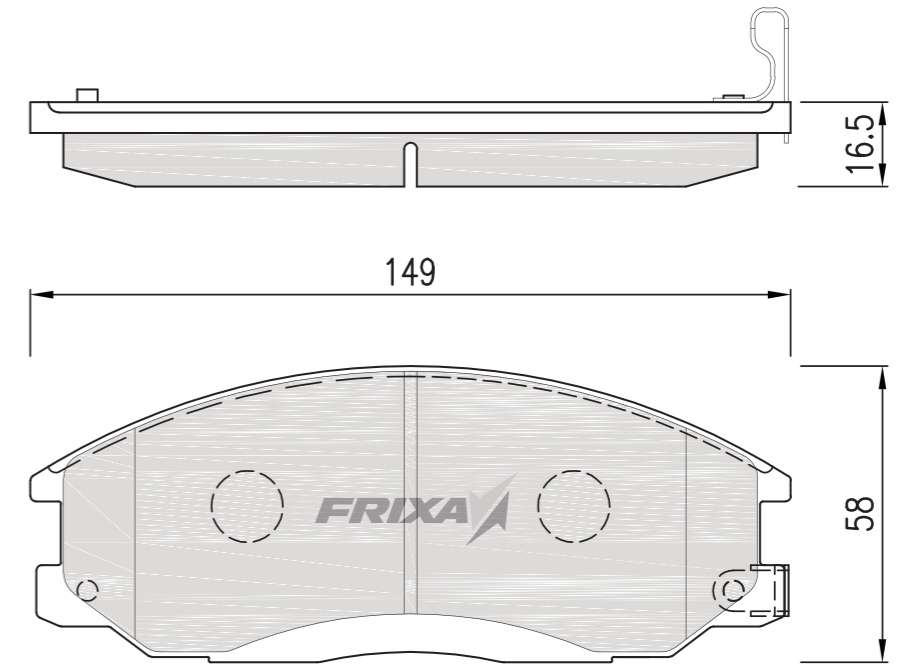

MAKER	HYUNDAI	PART NUMBER		OK52Y-3323Z		FRIXA CODE
REPRESENTATIVE MODEL	SANTAFE 4WD	INTERCHANGEABLE		SANTAFE4WD NEW GRANDEUR XG3.0 (12"DISC)		FPH11N
PO	SP	WVA	FMSI	HP	TRW	
FRONT	SP1115	23569	D864-7739	HP0014	GDB3244	

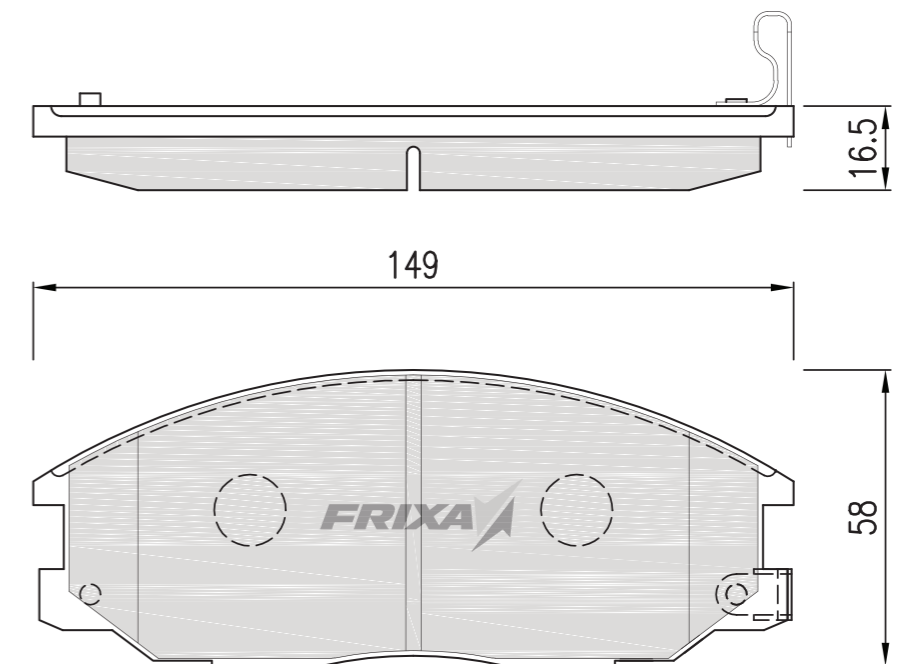

DISC BRAKE PAD

BRAKE SHOE ASSEMBLY

BRAKE LINING

DISC BRAKE PAD

BRAKE SHOE ASSEMBLY

BRAKE LINING

FRIXA CODE	MAKER	HYUNDAI	PART NUMBER		58101-H1A00	
FPH12	REPRESENTATIVE MODEL	TERRACAN	INTERCHANGEABLE		TERRACAN	
	PO	SP	WVA	FMSI	HP	TRW
	FRONT	SP1097	24059		HP0022	GDB3299

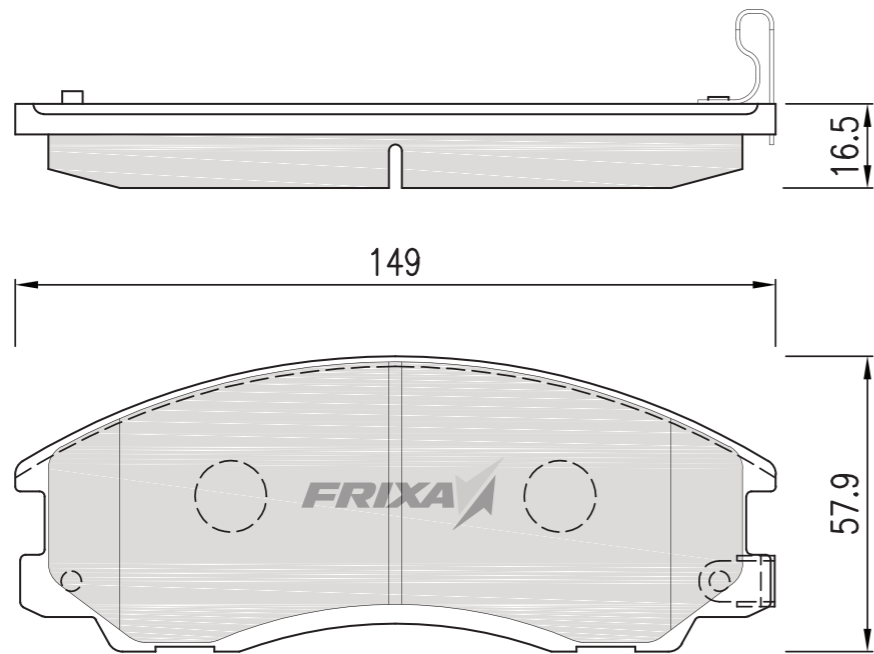

FRIXA CODE	MAKER	HYUNDAI	PART NUMBER		58101-1FA50	
FPH14	REPRESENTATIVE MODEL	TUCSON	INTERCHANGEABLE		TUCSON, NEW SPORTAGE	
	PO	SP	WVA	FMSI	HP	TRW
	FRONT	SP1155	23891	8306-D1125		GDB3352

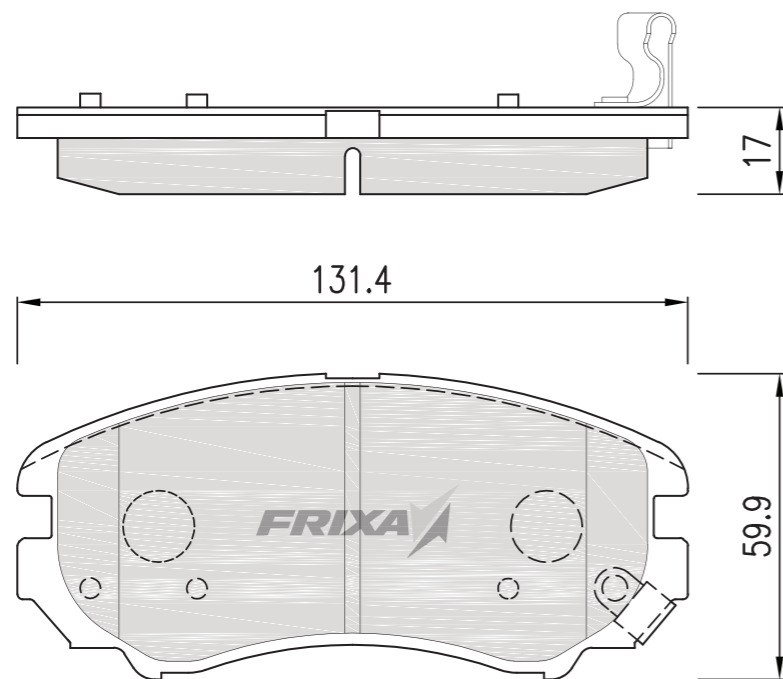

MAKER	HYUNDAI	PART NUMBER		58101-4FA00		FRIXA CODE
REPRESENTATIVE MODEL	PORTER II	INTERCHANGEABLE		PORTER II		FPH15
PO	SP	WVA	FMSI	HP	TRW	
FRONT	SP1174			HP0029		

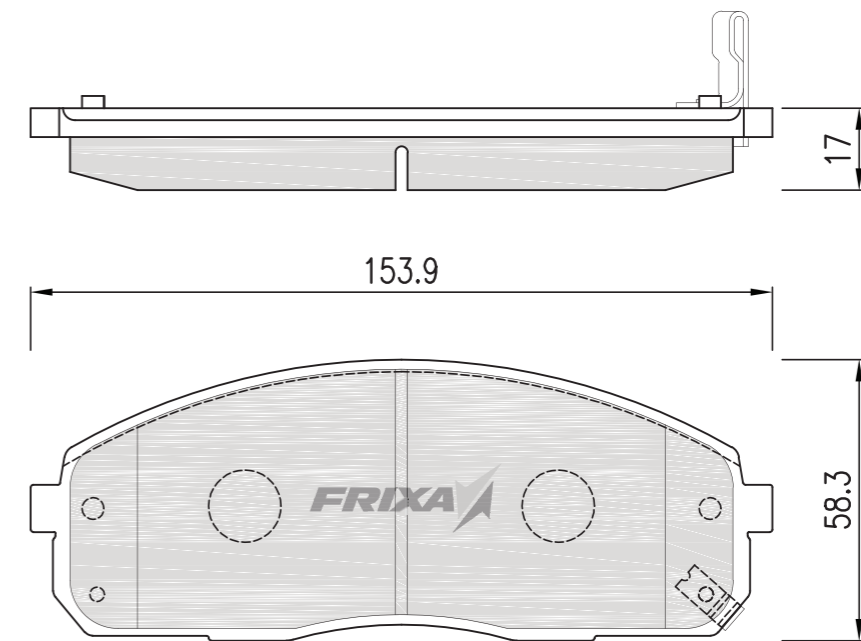

MAKER	HYUNDAI	PART NUMBER		58101-3BA20		FRIXA CODE
REPRESENTATIVE MODEL	EQUUS (NEW)4.5	INTERCHANGEABLE		EQUUS 3.0/3.5/4.5 (17" WHEEL) EQUUS NEW		FPH16
PO	SP	WVA	FMSI	HP	TRW	
FRONT	SP1206					

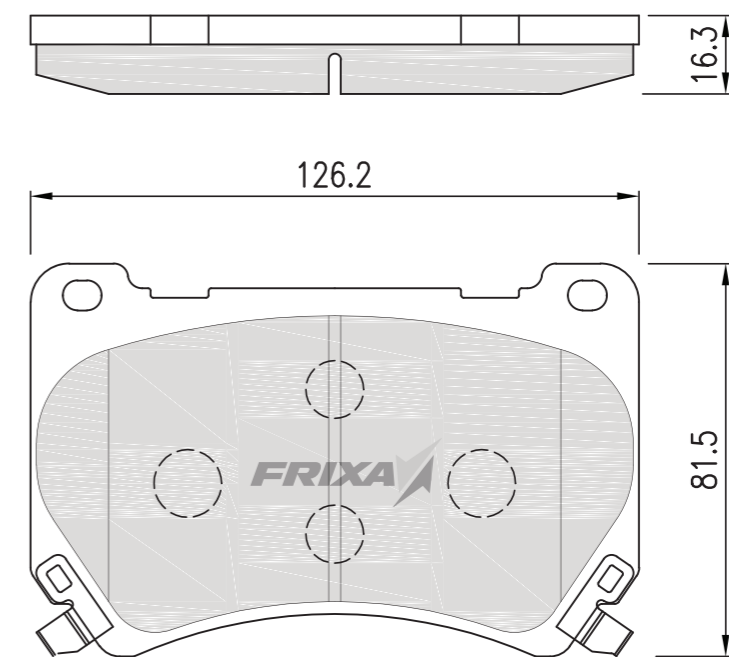

DISC BRAKE PAD

BRAKE SHOE ASSEMBLY

BRAKE LINING

DISC BRAKE PAD

BRAKE SHOE ASSEMBLY

BRAKE LINING

FRIXA CODE	MAKER	HYUNDAI	PART NUMBER		58101-3KA20	
FPH17	REPRESENTATIVE MODEL	GRANDEUR TG	INTERCHANGEABLE		NF SONATA 2.0/2.4 (16" WHEEL), NF TRANSFORM (16" WHEEL), LOTZE (16" WHEEL), LOTZE INNOVATION (16" WHEEL), OPIRUS(NEW), NF SONATA 16"	
	PO	SP	WVA	FMSI	HP	TRW
	FRONT	SP1182	23891	D1125-8233	HP0031	GDB3352

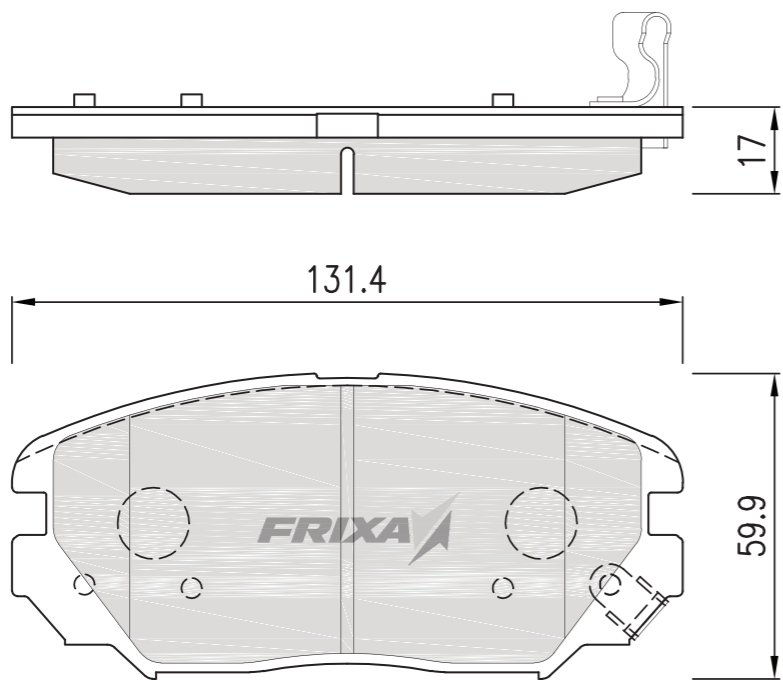

FRIXA CODE	MAKER	HYUNDAI	PART NUMBER		58101-0WA00	
FPH18	REPRESENTATIVE MODEL	SANTA FE CM	INTERCHANGEABLE		SANTA FE 06MY SORENTO R	
	PO	SP	WVA	FMSI	HP	TRW
	FRONT	SP1194	24351	D1202-8322		

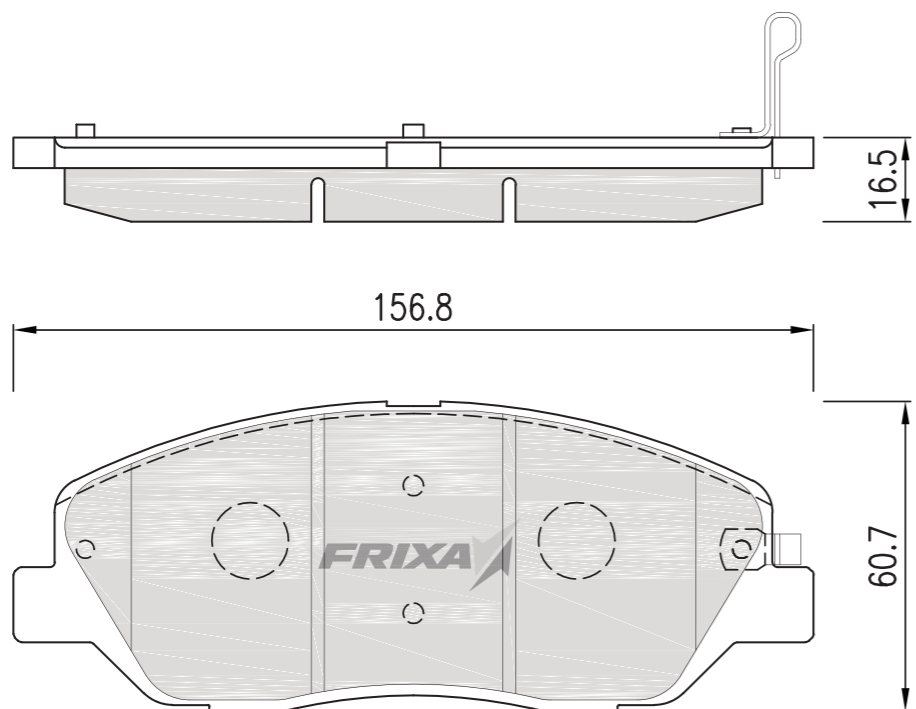

MAKER	HYUNDAI	PART NUMBER		58101-3JA00		FRIXA CODE
REPRESENTATIVE MODEL	VERACRUZ	INTERCHANGEABLE		VERACRUZ		FPH19
PO	SP	WVA	FMSI	HP	TRW	
FRONT	SP1203					

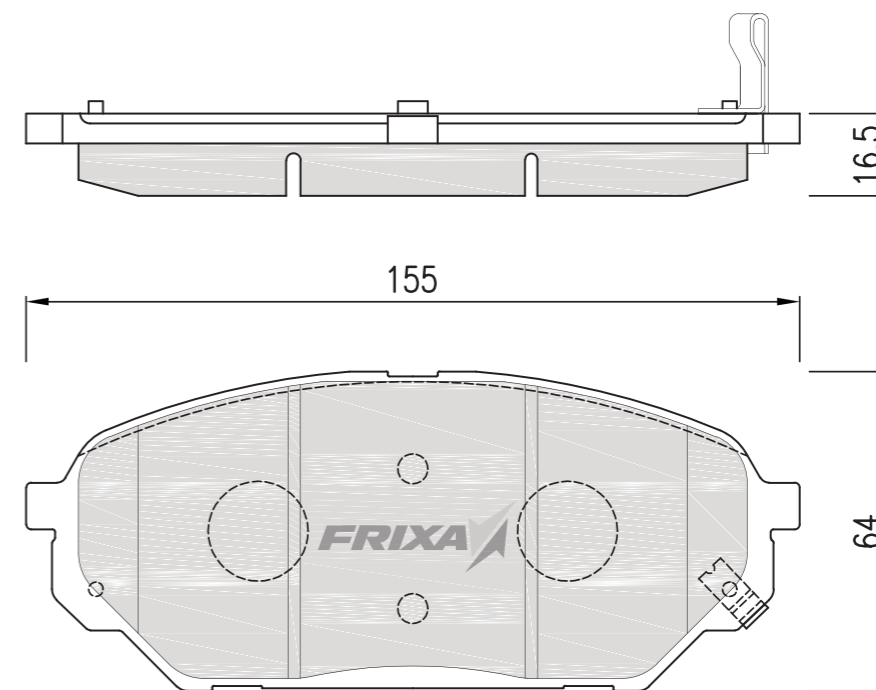

MAKER	HYUNDAI	PART NUMBER		58101-1MA00		FRIXA CODE
REPRESENTATIVE MODEL	i-30	INTERCHANGEABLE		i-30, FORTE		FPH20
PO	SP	WVA	FMSI	HP	TRW	
FRONT	SP1240	23966			GDB3342	

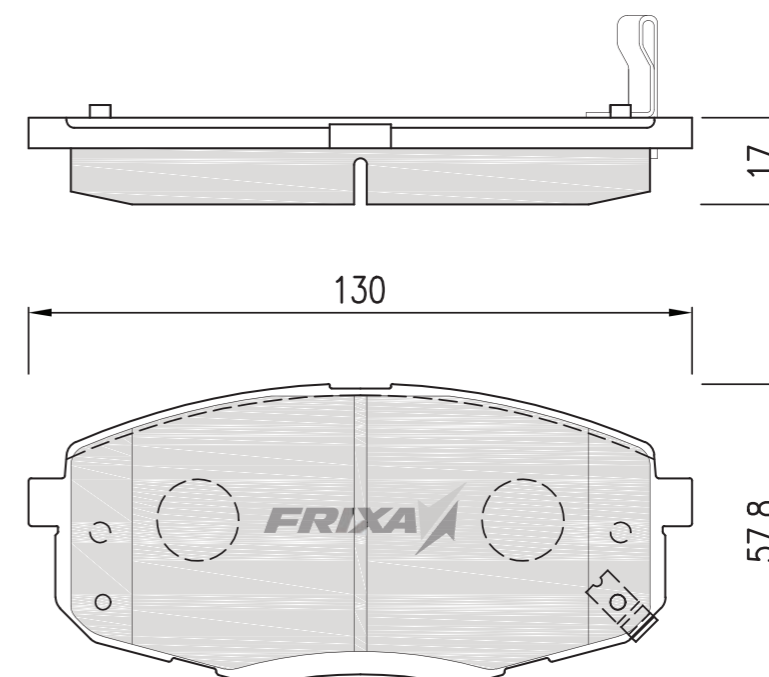

DISC BRAKE PAD

BRAKE SHOE ASSEMBLY

BRAKE LINING

DISC BRAKE PAD

BRAKE SHOE ASSEMBLY

BRAKE LINING

FRIXA CODE	MAKER	HYUNDAI	PART NUMBER		58101-2HA10	
FPH21	REPRESENTATIVE MODEL	AVANTE 06MY	INTERCHANGEABLE		AVANTE 06MY	
	PO	SP	WVA	FMSI	HP	TRW
	FRONT	SP1202	23891	8306-D1125		GDB3352

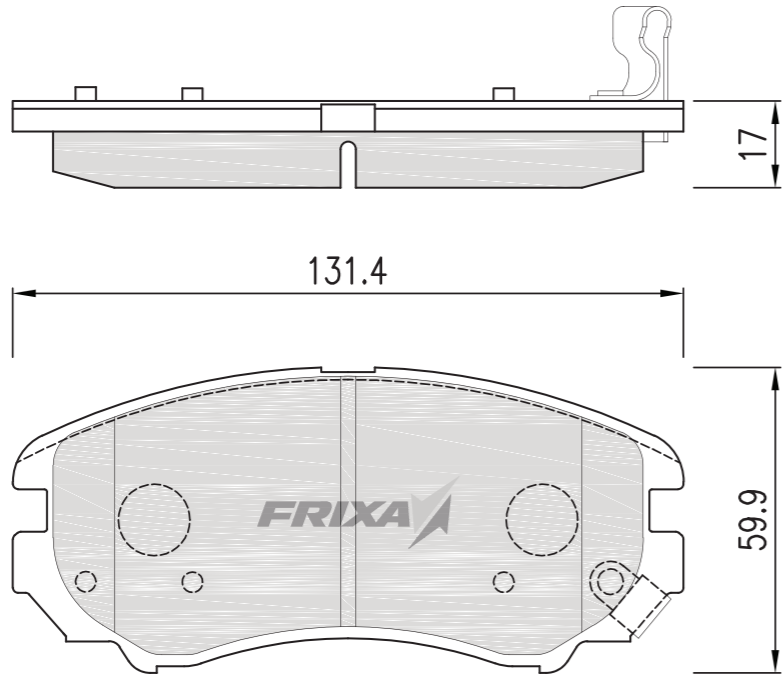

FRIXA CODE	MAKER	HYUNDAI	PART NUMBER		58160-5K300	
FPH22	REPRESENTATIVE MODEL	MIGHTY 06MY	INTERCHANGEABLE		MIGHTY 06MY, COUNTY 06MY	
	PO	SP	WVA	FMSI	HP	TRW
	FRONT	SP1207				

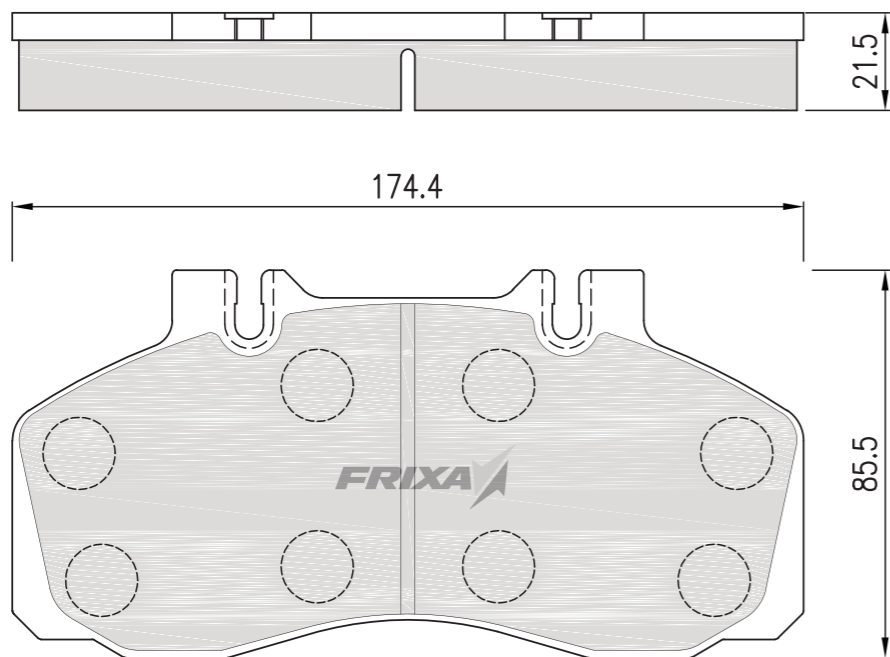

MAKER	HYUNDAI	PART NUMBER		58101-3MA00		FRIXA CODE
REPRESENTATIVE MODEL	GENESIS	INTERCHANGEABLE		GENESIS		FPH23
PO	SP	WVA	FMSI	HP	TRW	
FRONT	SP1246		D1384-8400			

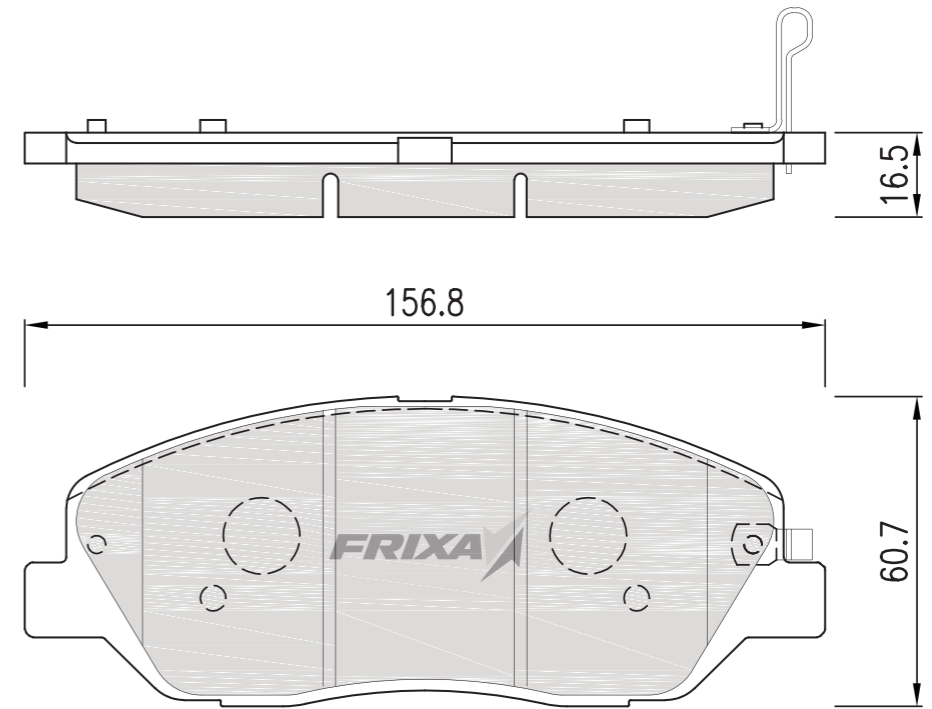

MAKER	HYUNDAI	PART NUMBER		58101-2MA10		FRIXA CODE
REPRESENTATIVE MODEL	GENESIS COUPE	INTERCHANGEABLE		GENESIS COUPE		FPH24
PO	SP	WVA	FMSI	HP	TRW	
FRONT						

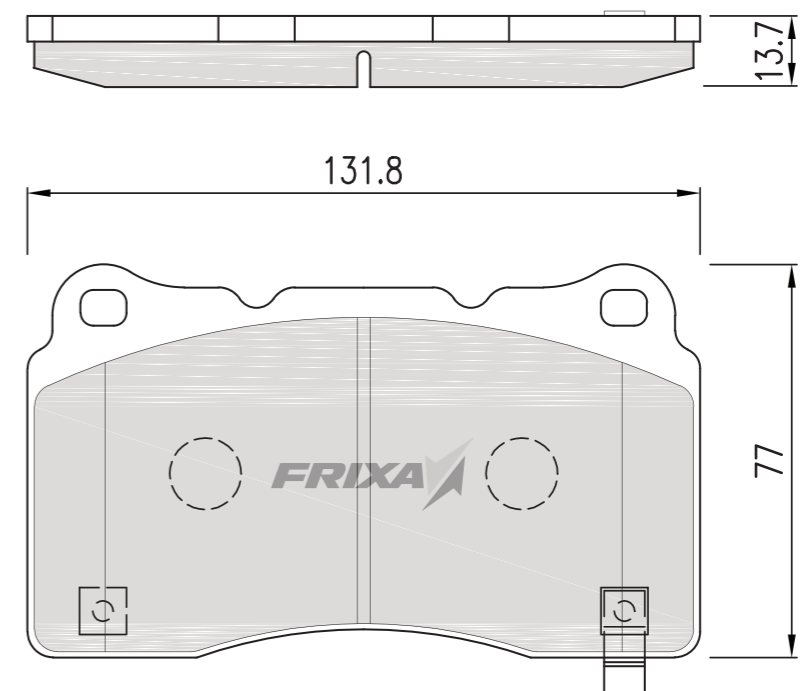

DISC BRAKE PAD

BRAKE SHOE ASSEMBLY

BRAKE LINING

DISC BRAKE PAD

BRAKE SHOE ASSEMBLY

BRAKE LINING

FRIXA CODE	MAKER	HYUNDAI	PART NUMBER		58101-3SA20	
FPH25	REPRESENTATIVE MODEL	YF SONATA	INTERCHANGEABLE		YF SONATA, TUCSON IX 2WD	
	PO	SP	WVA	FMSI	HP	TRW
	FRONT					

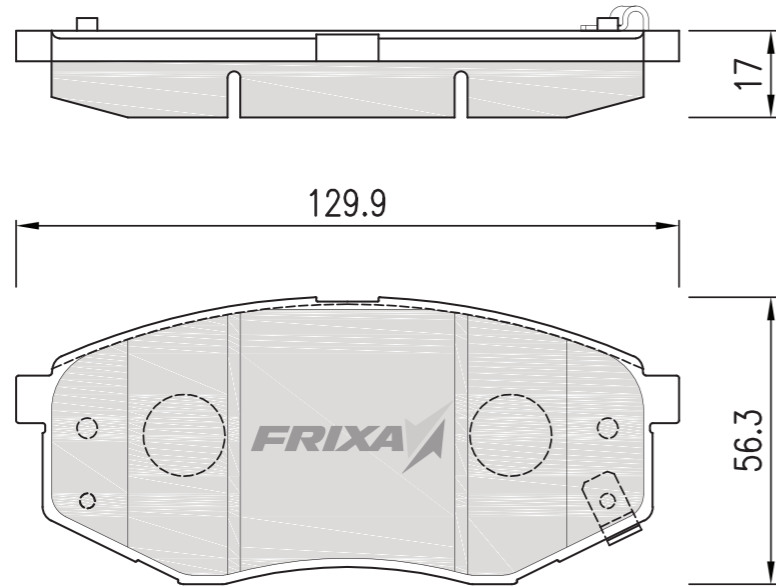

FRIXA CODE	MAKER	HYUNDAI	PART NUMBER		58101-3XA00	
FPH26	REPRESENTATIVE MODEL	AVANTE MD	INTERCHANGEABLE		AVANTE MD	
	PO	SP	WVA	FMSI	HP	TRW
	FRONT					

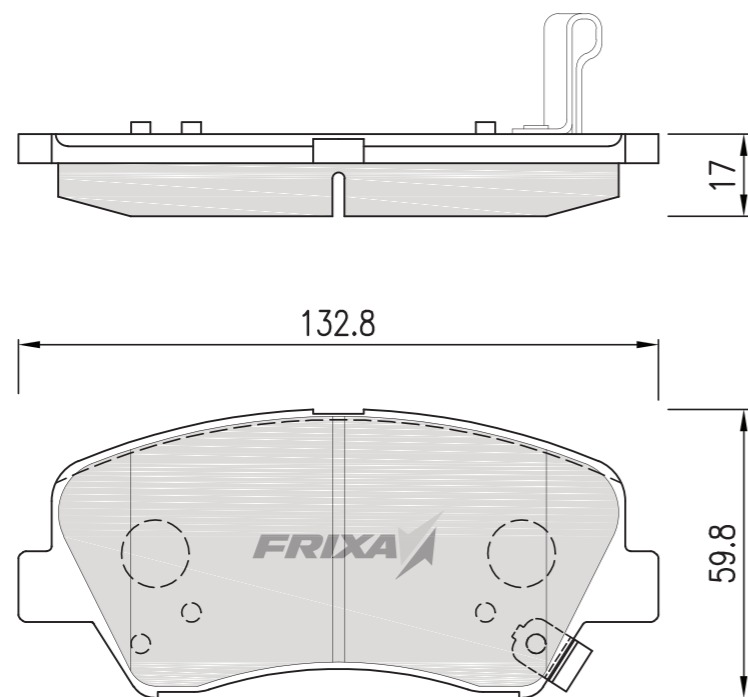

MAKER	HYUNDAI	PART NUMBER		FRIXA CODE	
REPRESENTATIVE MODEL	ACCENT	INTERCHANGEABLE		ACCENT NEW	
PO	SP	WVA	FMSI	HP	TRW
FRONT	SP1399				

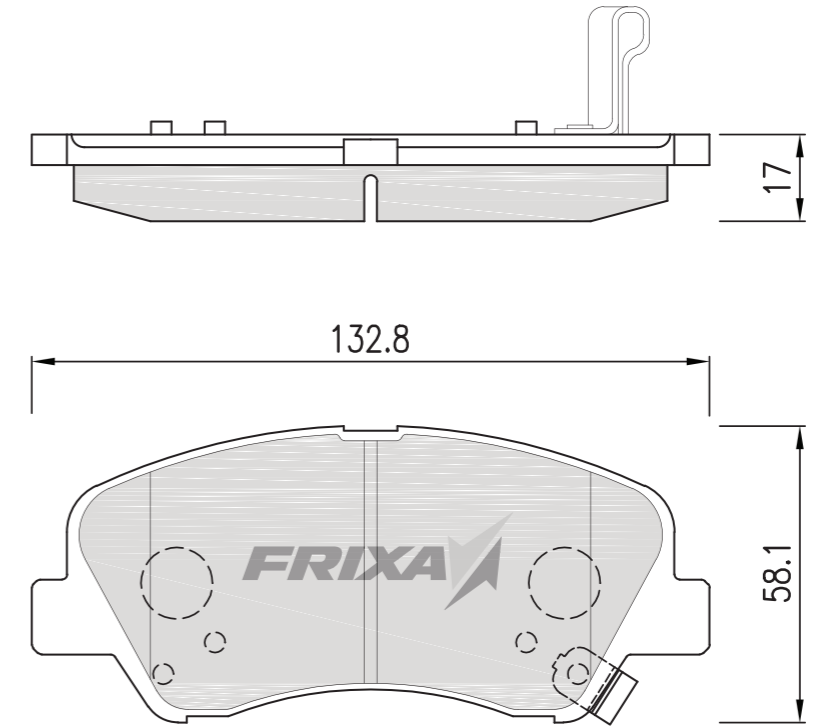

MAKER	HYUNDAI	PART NUMBER		FRIXA CODE	
REPRESENTATIVE MODEL	AVANTE XD	INTERCHANGEABLE		AVANTE XD1.5	
PO	SP	WVA	FMSI	HP	TRW
FRONT	SP1147			HP0020	

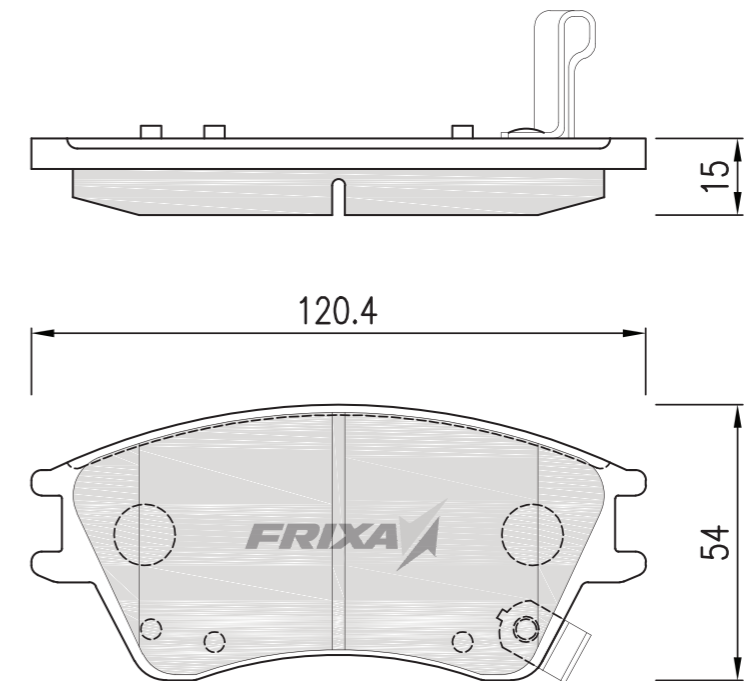

DISC BRAKE PAD

BRAKE SHOE ASSEMBLY

BRAKE LINING

DISC BRAKE PAD

BRAKE SHOE ASSEMBLY

BRAKE LINING

FRIXA CODE	MAKER	HYUNDAI	PART NUMBER		58115-391S0	
FPHXGF	REPRESENTATIVE MODEL	GRANDEUR XG	INTERCHANGEABLE		GRANDEUR XG 2.5/3.0(15"WHEEL) GRANDEUR XG 2.7TAXI(15"WHEEL)	
	PO	SP	WVA	FMSI	HP	TRW
	FRONT	SP1190			HP0015	

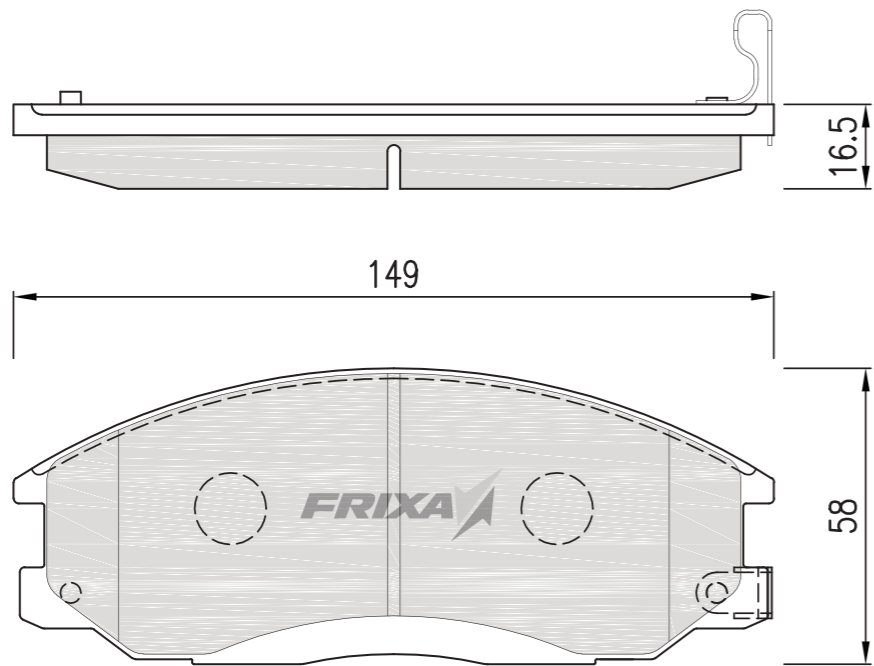

FRIXA CODE	MAKER	HYUNDAI	PART NUMBER		48130-21A00	
FPHXGN	REPRESENTATIVE MODEL	NEW GRANDEUR XG	INTERCHANGEABLE		GRANDEUR XG 2.5/3.0(16"WHEEL), EQUUS 3.0/3.5(16"WHEEL), EQUUS4.5, OPIRUS, RODIUS, NEW TERRACAN, TRAGET XG(16"WHEEL)	
	PO	SP	WVA	FMSI	HP	TRW
	FRONT	SP1161	23726	D1013-7917	HP0016	GDB3257

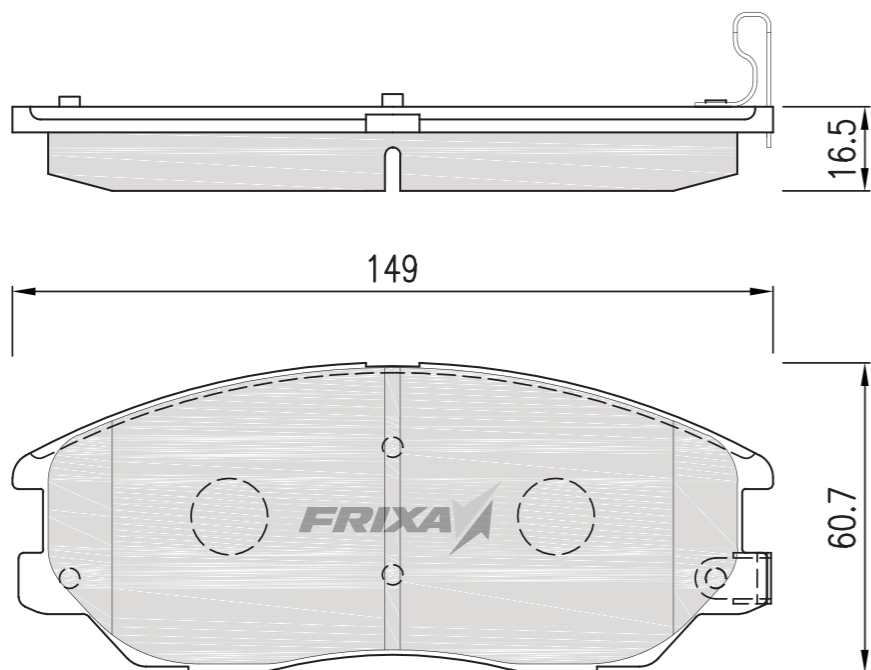

MAKER	HYUNDAI	PART NUMBER		44060-02E90		FRIXA CODE
REPRESENTATIVE MODEL	AVANTE	INTERCHANGEABLE		ELANTRA, TIBURON, TUSCANI 2.0/2.7, AVANTE AVANTE XD, NEW AVANTE XD1.6, CERATO		FPH01R
PO	SP	WVA	FMSI	HP	TRW	
REAR	SP1062	21553	D323-7146	HP0021	GDB1010	

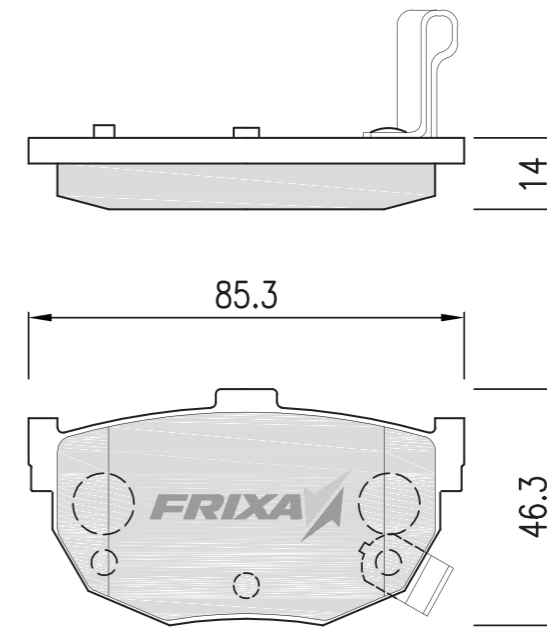

MAKER	HYUNDAI	PART NUMBER		43022-SD4000		FRIXA CODE
REPRESENTATIVE MODEL	SONATA	INTERCHANGEABLE		SONATA II/III, MARCIA		FPH02NR
PO	SP	WVA	FMSI	HP	TRW	
REAR	SP1074	20029	D342-7236	HP0005	GDB994	

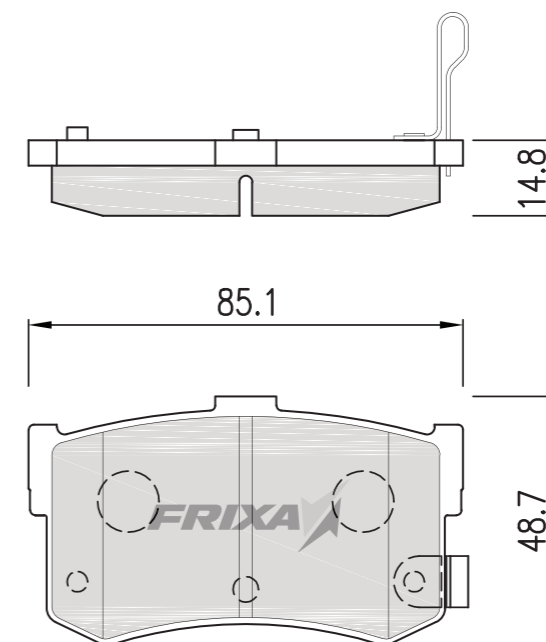

DISC BRAKE PAD

BRAKE SHOE ASSEMBLY

BRAKE LINING

DISC BRAKE PAD

BRAKE SHOE ASSEMBLY

BRAKE LINING

FRIXA CODE	MAKER	HYUNDAI	PART NUMBER		58215-375A0	
FPH04R	REPRESENTATIVE MODEL	NEW GRANDEUR 2.0	INTERCHANGEABLE		NEW GRANDEUR 2.0, CARSTAR NEW GRANDEUR 2.5, SANTAMO	
	PO	SP	WVA	FMSI	HP	TRW
	REAR	SP1054-R	23608		HP0011	

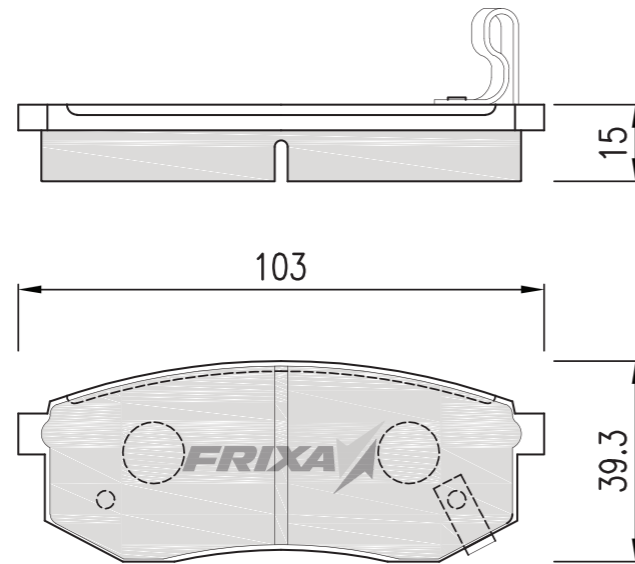

FRIXA CODE	MAKER	HYUNDAI	PART NUMBER		58215-375A0	
FPH05R	REPRESENTATIVE MODEL	NEW GRANDEUR 3.0	INTERCHANGEABLE		NEW GRANDEUR 2.5, DYNASTY NEW GRANDEUR 3.0/3.5, EQUUS	
	PO	SP	WVA	FMSI	HP	TRW
	REAR	SP1082			HP0013	

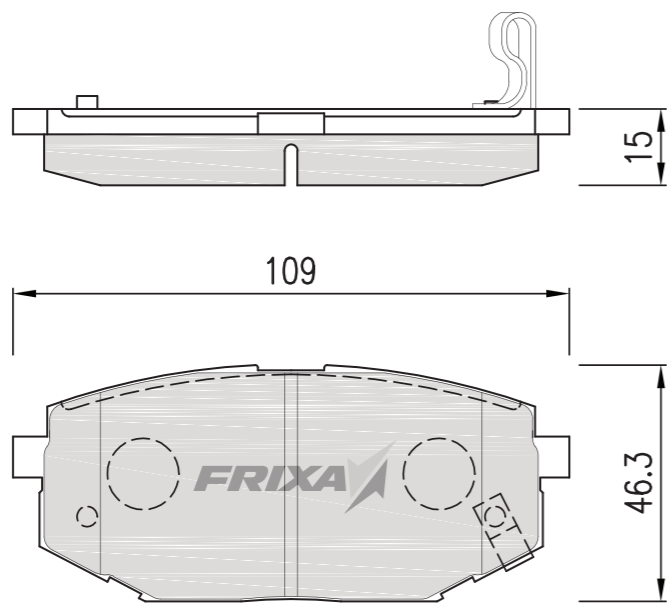

MAKER	HYUNDAI	PART NUMBER		58302-2BA00		FRIXA CODE
REPRESENTATIVE MODEL	STAREX	INTERCHANGEABLE		STAREX(NEW), SANTA FE 06MY		FPH09R
PO	SP	WVA	FMSI	HP	TRW	
REAR	SP1178	24464	D1297-8414			

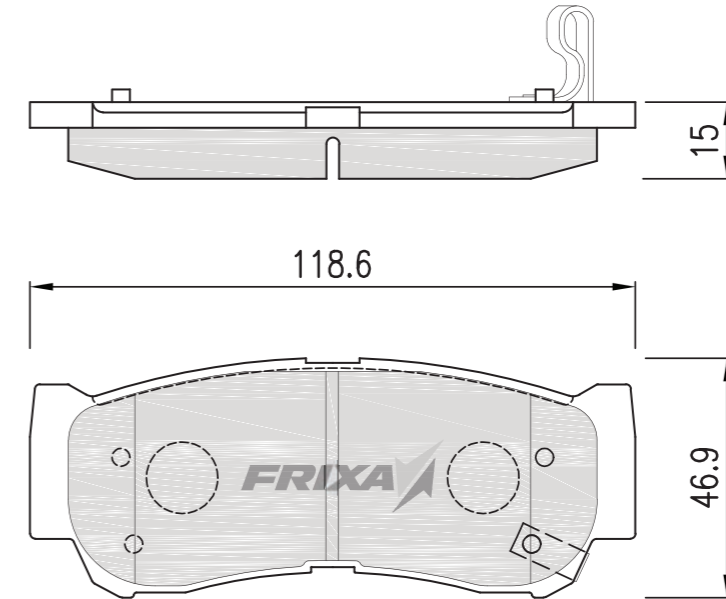

MAKER	HYUNDAI	PART NUMBER		58302-H1A00		FRIXA CODE
REPRESENTATIVE MODEL	TERRACAN	INTERCHANGEABLE		TERRACAN, TERRACAN NEW		FPH12R
PO	SP	WVA	FMSI	HP	TRW	
REAR	SP1098	23813		HP0023	GDB3296	

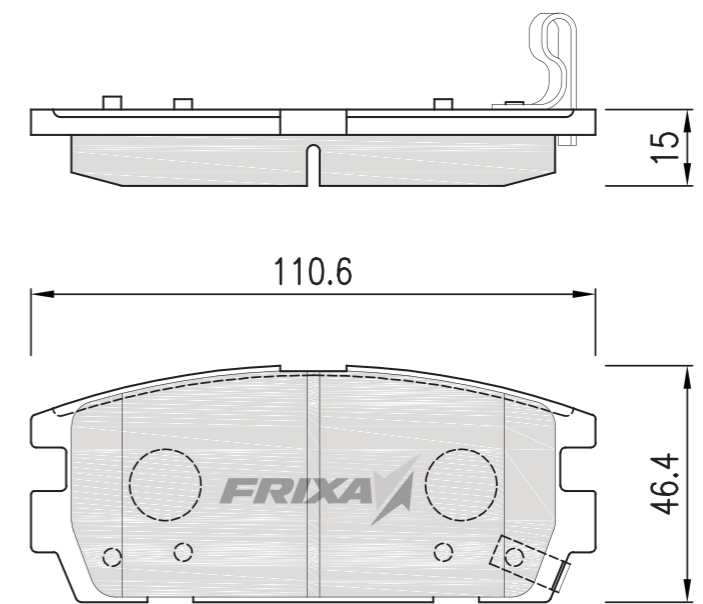

DISC BRAKE PAD

DISC BRAKE PAD

DISC BRAKE PAD

DISC BRAKE PAD

DISC BRAKE PAD

DISC BRAKE PAD

FRIXA CODE	MAKER	HYUNDAI	PART NUMBER		58302-2EA31	
FPH17R	REPRESENTATIVE MODEL	NF TRANSFORM	INTERCHANGEABLE		NF TRANSFORM, OPIRUS 06MY SOUL, LOTZE INNOVATION	
	PO	SP	WVA	FMSI	HP	TRW
	REAR	SP1239		D1313-8428		

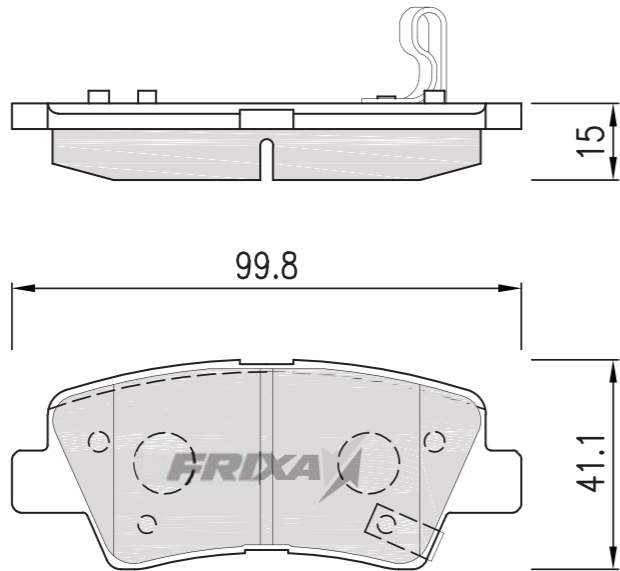

FRIXA CODE	MAKER	HYUNDAI	PART NUMBER		58302-3JA00	
FPH19R	REPRESENTATIVE MODEL	VERACRUZ	INTERCHANGEABLE		VERACRUZ, GRAND STAREX GRAND CARNIVAL	
	PO	SP	WVA	FMSI	HP	TRW
	REAR	SP1192	24599	D1302-8418		GDB3449

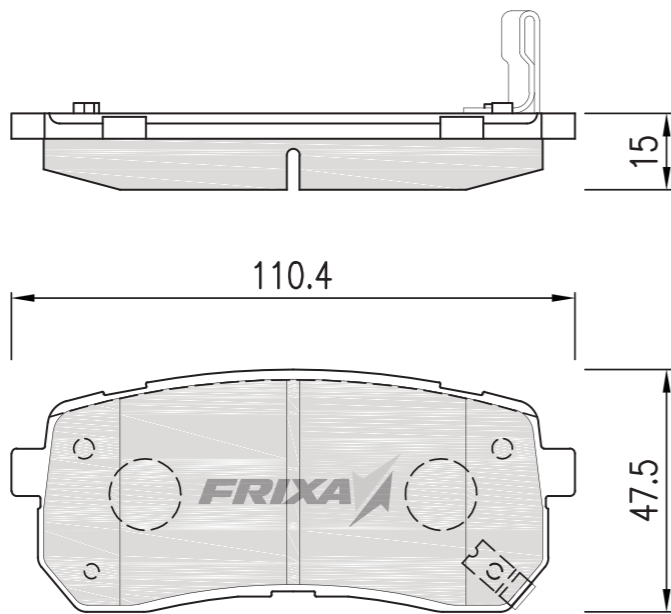

MAKER	HYUNDAI	PART NUMBER		58302-2MA10		FRIXA CODE
REPRESENTATIVE MODEL	GENESIS COUPE	INTERCHANGEABLE		GENESIS COUPE		FPH24R
PO	SP	WVA	FMSI	HP	TRW	
REAR						

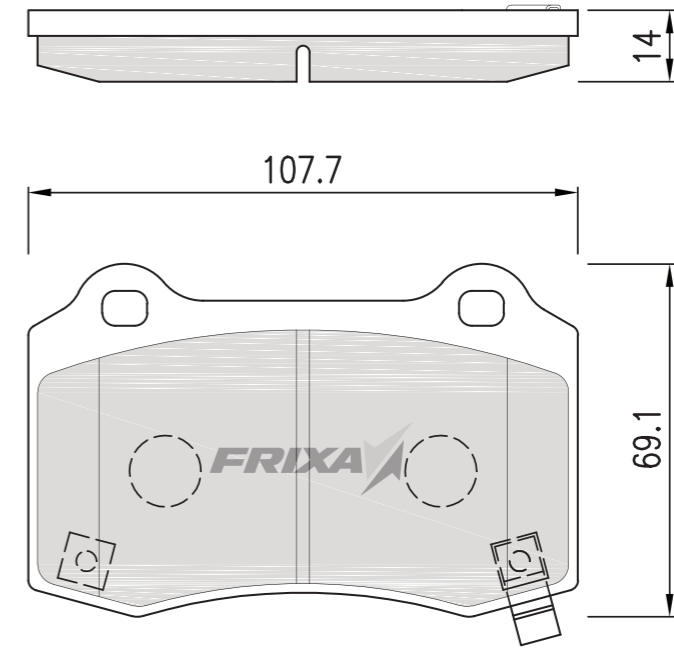

MAKER	HYUNDAI	PART NUMBER		58302-1GA00		FRIXA CODE
REPRESENTATIVE MODEL	YF SONATA	INTERCHANGEABLE		PRIDE 05MY, VERNA 05MY, i-30 YF SONATA, TUCSON IX		FPH25R
PO	SP	WVA	FMSI	HP	TRW	
REAR	SP1187	24320	D1157-8267		GDB3421	

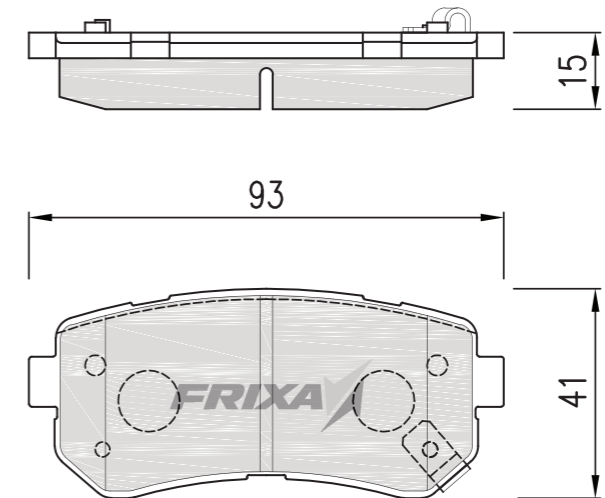

DISC BRAKE PAD

BRAKE SHOE ASSEMBLY

BRAKE LINING

DISC BRAKE PAD

BRAKE SHOE ASSEMBLY

BRAKE LINING

FRIXA CODE	MAKER	HYUNDAI	PART NUMBER		58302-3XA30, 58302-1RA30	
FPH26R	REPRESENTATIVE MODEL	AVANTE MD	INTERCHANGEABLE		AVANTE MD(10.08~) ACCENT 11MY R	
	PO	SP	WVA	FMSI	HP	TRW
	REAR	SP1401				

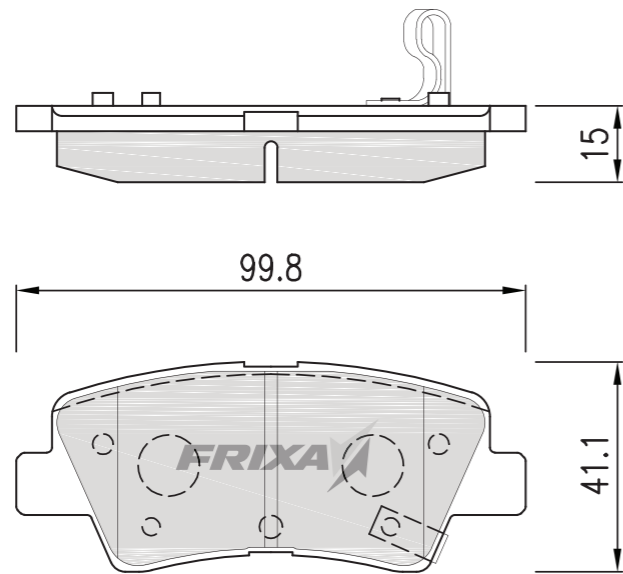

FRIXA CODE	MAKER	HYUNDAI	PART NUMBER		58215-383S0	
FPHXGR	REPRESENTATIVE MODEL	GRANDEUR XG	INTERCHANGEABLE		EF SONATA, NEW EFSONATA, GRANDEUR XG, NEW GRANDEUR XG, NF SONATA, LOTZE, OPIRUS, OPTIMA/OPTIMA REGAL, GFANDEUR TG.	
	PO	SP	WVA	FMSI	HP	TRW
	REAR	SP1117	23543	D813-7688	HP0008	GDB3282

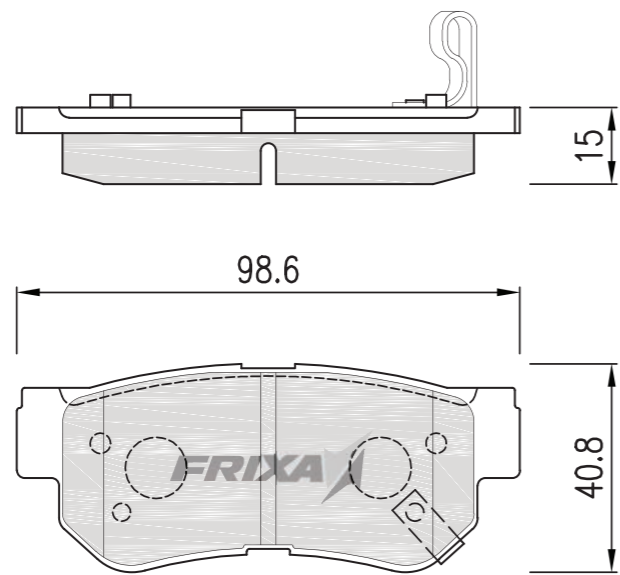

MAKER	KIA	PART NUMBER		B5Y8-3323Z		FRIXA CODE
REPRESENTATIVE MODEL	PRIDE	INTERCHANGEABLE		PRIDE/PRIDE BETA		FPK01
PO	SP	WVA	FMSI	HP	TRW	
FRONT	SP1049	21355	D402-7291	HP1001	GDB773	

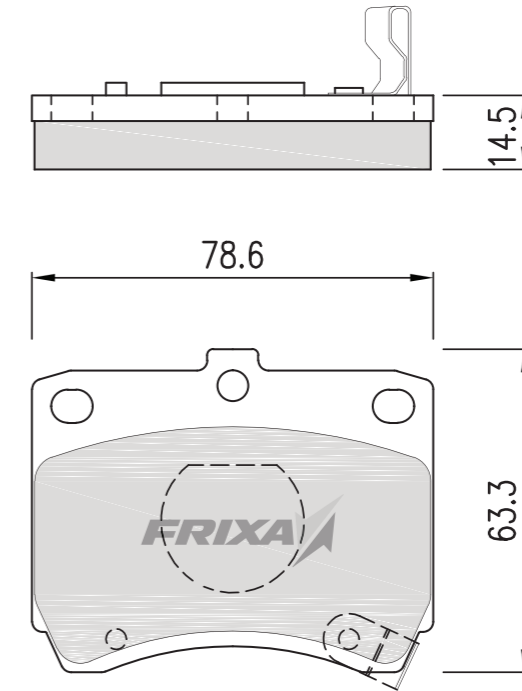

MAKER	KIA	PART NUMBER		58101-1G000		FRIXA CODE
REPRESENTATIVE MODEL	PRIDE(NEW)	INTERCHANGEABLE		PRIDE 05MY, VERNA 05MY		FPK01N
PO	SP	WVA	FMSI	HP	TRW	
FRONT	SP1186	24317	D1156-8266		GDB3420	

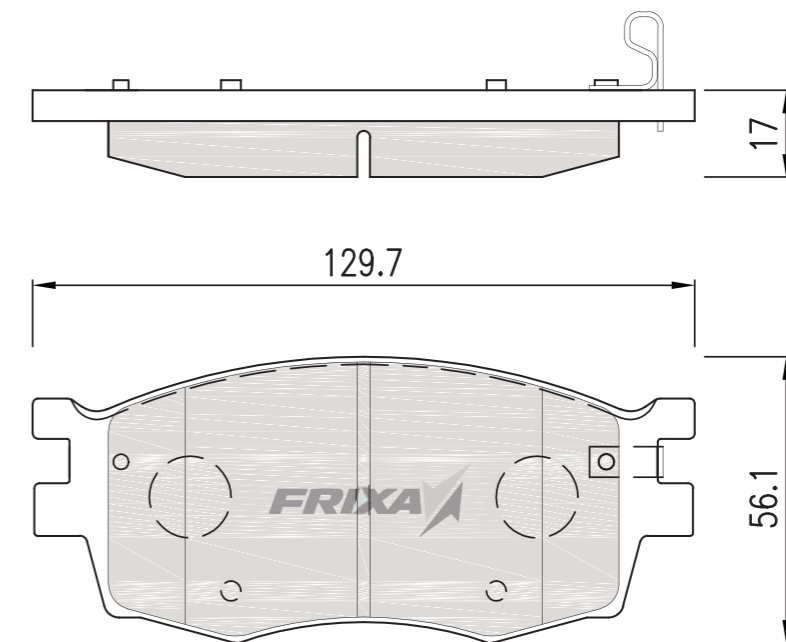

DISC BRAKE PAD

BRAKE SHOE ASSEMBLY

BRAKE LINING

DISC BRAKE PAD

BRAKE SHOE ASSEMBLY

BRAKE LINING

FRIXA CODE	MAKER	KIA	PART NUMBER		OK20A-3323Z	
FPK03	REPRESENTATIVE MODEL	SEPHIA	INTERCHANGEABLE		SEPHIA I / II, SHUMA	
	PO	SP	WVA	FMSI	HP	TRW
	FRONT	SP1063	23384	D649-7529	HP1003	GDB3096

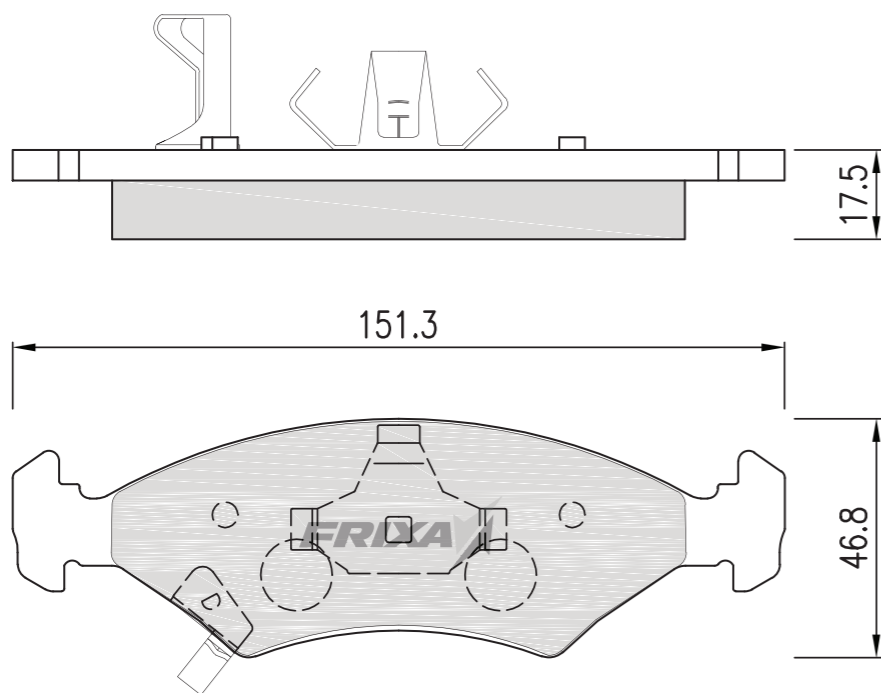

FRIXA CODE	MAKER	KIA	PART NUMBER		OK9A0-3328Z	
FPK04	REPRESENTATIVE MODEL	CREDOS	INTERCHANGEABLE		CREDOS	
	PO	SP	WVA	FMSI	HP	TRW
	FRONT	SP1079-F	23450		HP1007	GDB3173

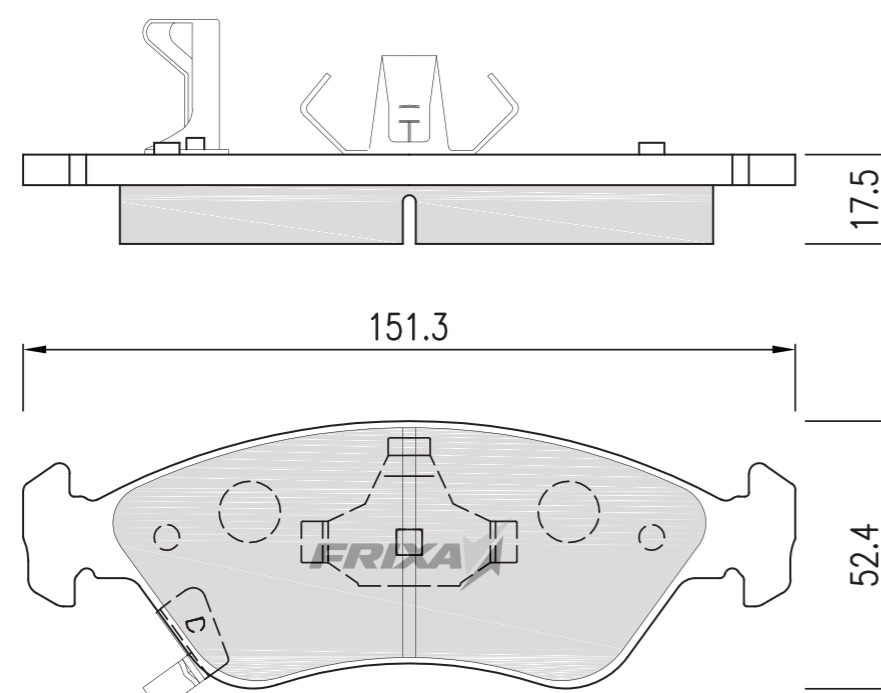

MAKER	KIA	PART NUMBER		OK2N1-3328Z		FRIXA CODE
REPRESENTATIVE MODEL	CREDOSII	INTERCHANGEABLE		CREDOSII, CARENS RIO SF1.5 (14"WHEEL), SPECTRA		FPK04N
PO	SP	WVA	FMSI	HP	TRW	
FRONT	SP1113	23873	D889-7767	HP1008	GDB3245	

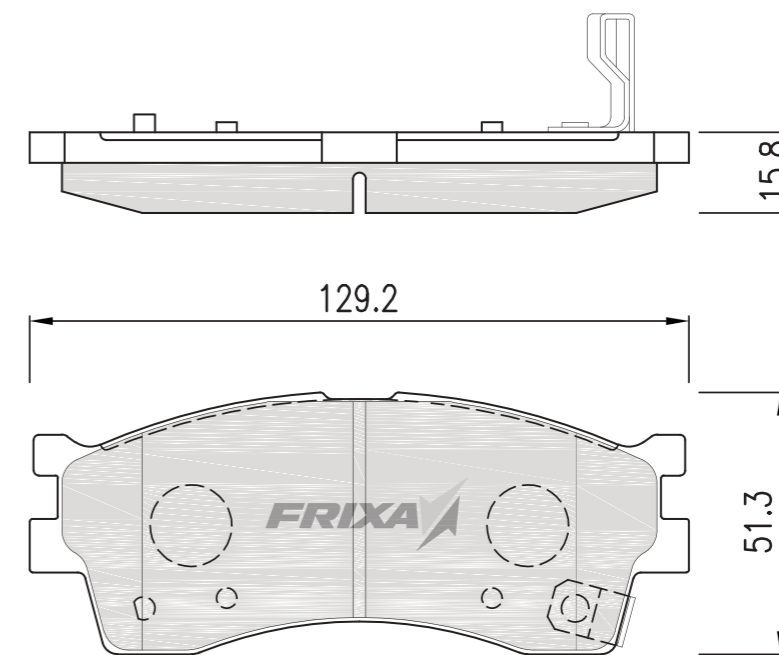

MAKER	KIA	PART NUMBER		OK30A-3328Z		FRIXA CODE
REPRESENTATIVE MODEL	AVELLA	INTERCHANGEABLE		AVELLA, ELAN, RIO		FPK05
PO	SP	WVA	FMSI	HP	TRW	
FRONT	SP1067	21654	D466-7219	HP1002	GDB1024	

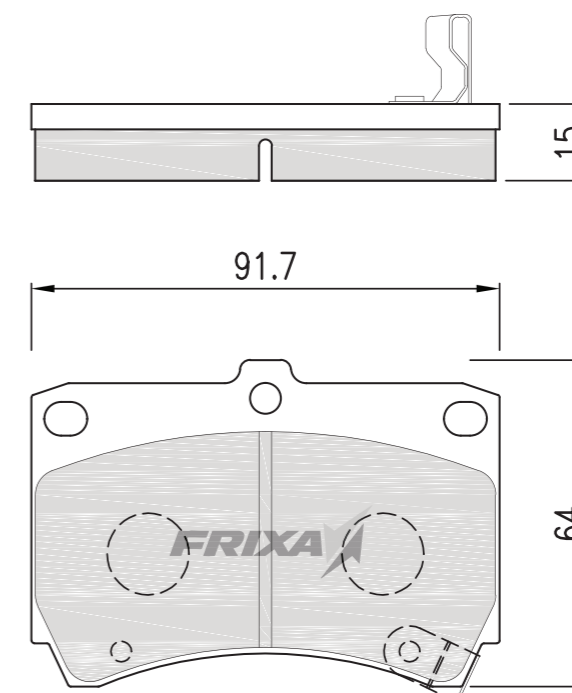

DISC BRAKE PAD

BRAKE SHOE ASSEMBLY

BRAKE LINING

DISC BRAKE PAD

BRAKE SHOE ASSEMBLY

BRAKE LINING

FRIXA CODE	MAKER	KIA		PART NUMBER		
FPK06	REPRESENTATIVE MODEL	POTENSIA	INTERCHANGEABLE	POTENSIA		
	PO	SP	WVA	FMSI	HP	TRW
	FRONT	SP1060-F	21318	7276-D389	HP1005	

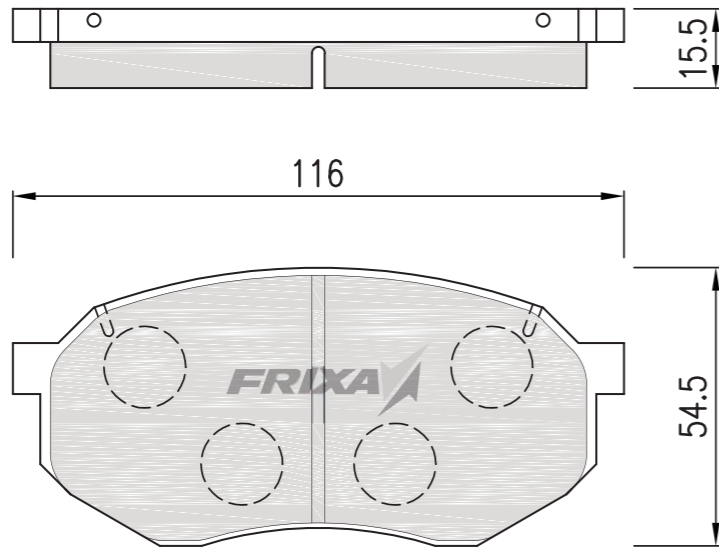

FRIXA CODE	MAKER	KIA (FRONT)		PART NUMBER		
FPK07	REPRESENTATIVE MODEL	SPORTAGE	INTERCHANGEABLE	SPORTAGE OLD		
	PO	SP	WVA	FMSI	HP	TRW
	FRONT	SP1070	21892	D670-7550	HP1028	GDB3123

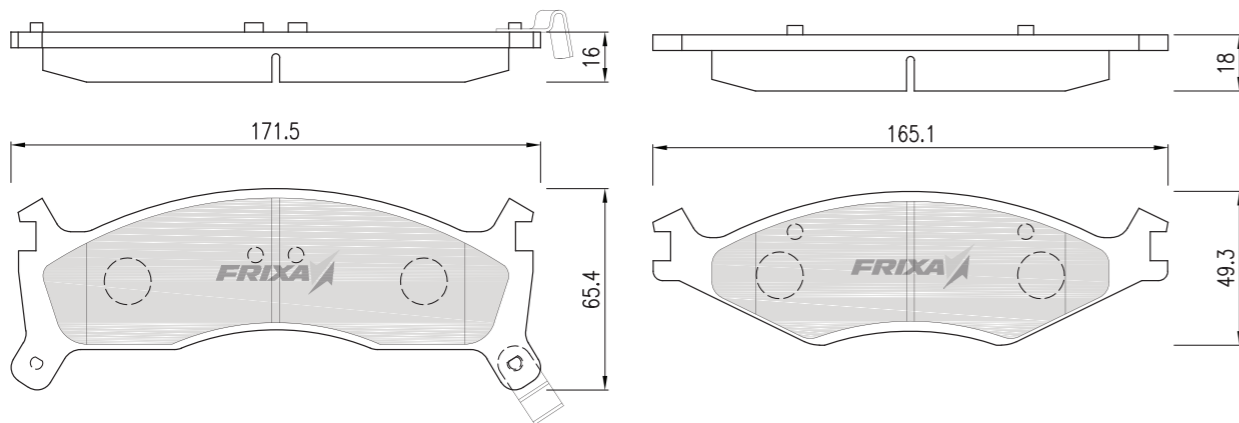

MAKER	KIA		PART NUMBER		FRIXA CODE
REPRESENTATIVE MODEL	NEW SPORTAGE	INTERCHANGEABLE	NEW SPORTAGE, RETONA		FPK07N
PO	SP	WVA	FMSI	HP	
FRONT	SP1118	23442	D774-7641	HP1015	

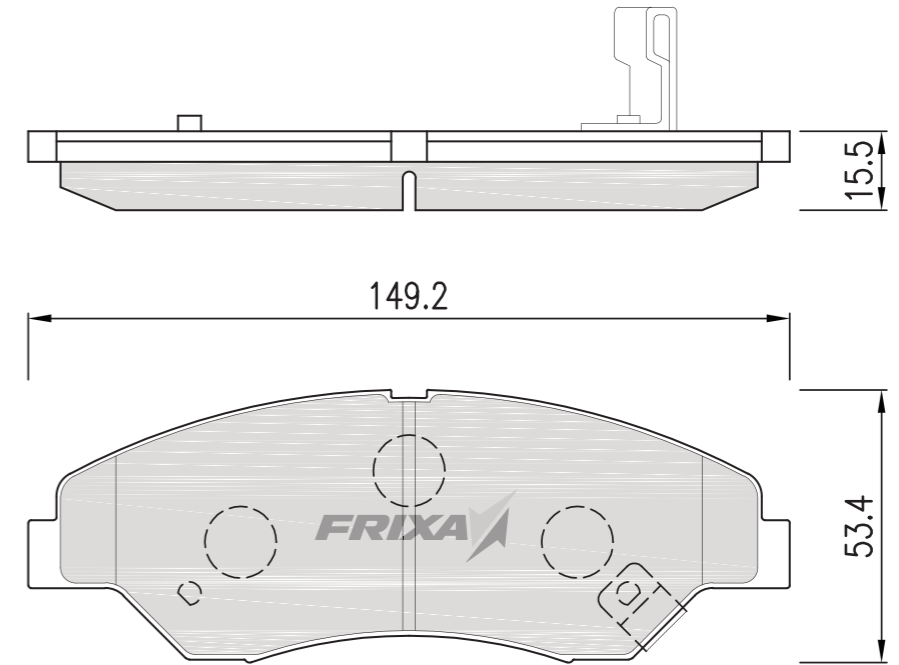

MAKER	KIA		PART NUMBER		FRIXA CODE
REPRESENTATIVE MODEL	BESTA	INTERCHANGEABLE	BESTA, WIDE BONGO, FRONTIER OLD		FPK08
PO	SP	WVA	FMSI	HP	
FRONT	SP1044	20002	D1199-8319	HP1010	

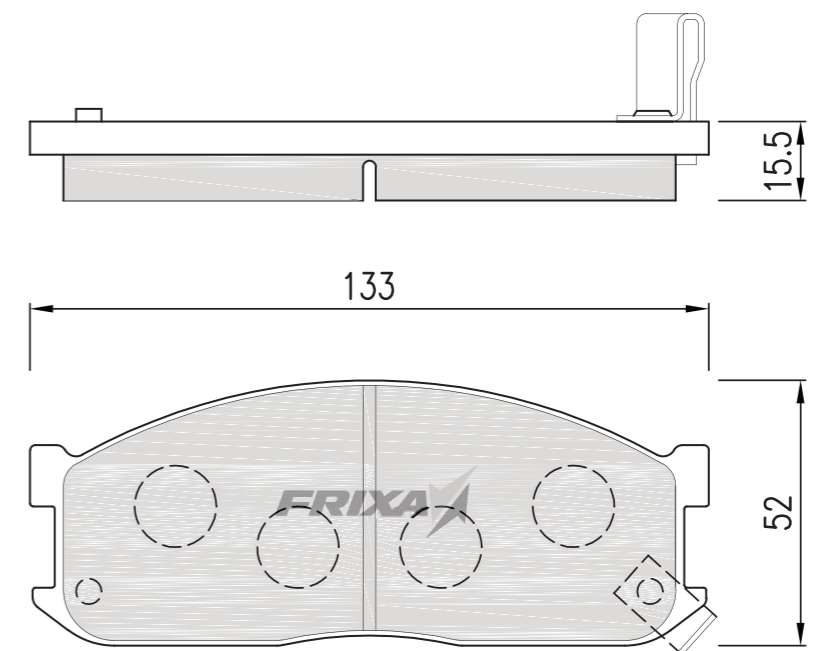

DISC BRAKE PAD

BRAKE SHOE ASSEMBLY

BRAKE LINING

DISC BRAKE PAD

BRAKE SHOE ASSEMBLY

BRAKE LINING

FRIXA CODE	MAKER	KIA		PART NUMBER		
FPK09	REPRESENTATIVE MODEL	NEW FRONTIER	INTERCHANGEABLE	OK60A-3328ZA		
	PO	SP	WVA	FMSI	HP	TRW
	FRONT	SP1056	23784		HP1014	GDB3145

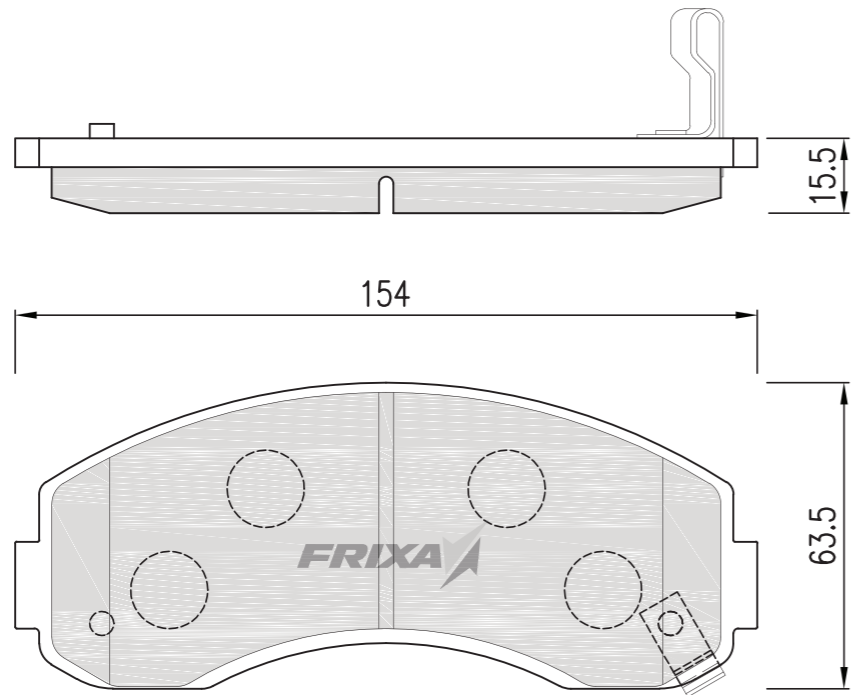

FRIXA CODE	MAKER	KIA		PART NUMBER		
FPK10	REPRESENTATIVE MODEL	PREGIO	INTERCHANGEABLE	OK72A-3328Z		
	PO	SP	WVA	FMSI	HP	TRW
	FRONT	SP1091	23484		HP1013	GDB3263

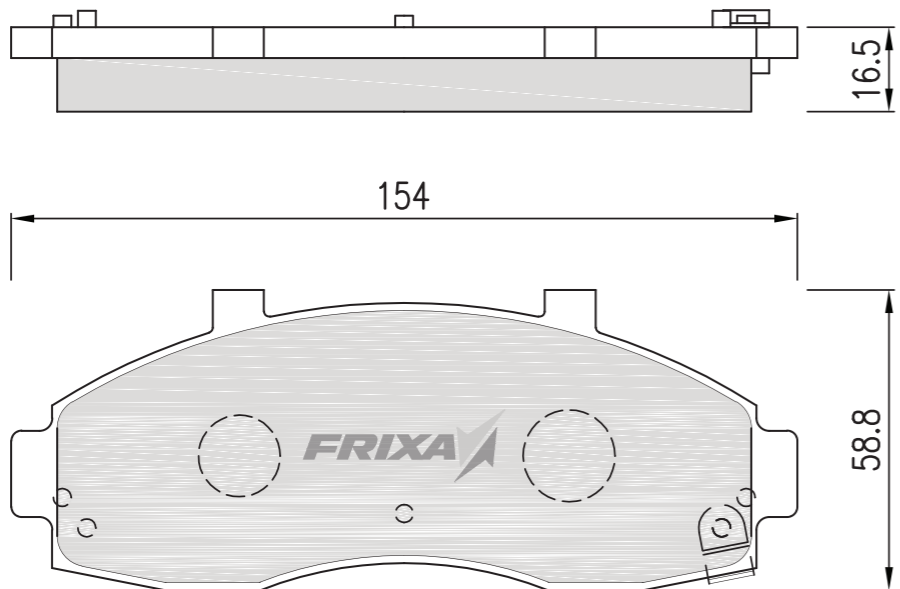

MAKER	KIA		PART NUMBER		FRIXA CODE	
REPRESENTATIVE MODEL	PREGIO NEW	INTERCHANGEABLE	OK56A-3323Z		FPK10N	
PO	SP	WVA	FMSI	HP		TRW
FRONT	SP1116	23649		HP1012		GDB3261

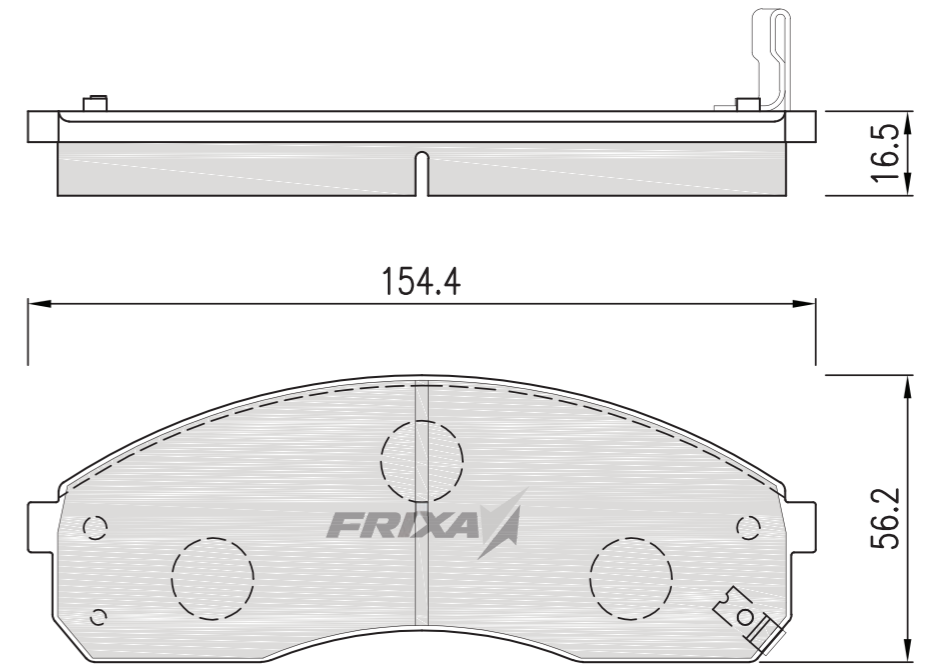

MAKER	KIA		PART NUMBER		FRIXA CODE	
REPRESENTATIVE MODEL	TOWNER	INTERCHANGEABLE	AA100-33625		FPK11	
PO	SP	WVA	FMSI	HP		TRW
FRONT	SP1073	20780		HP1019		

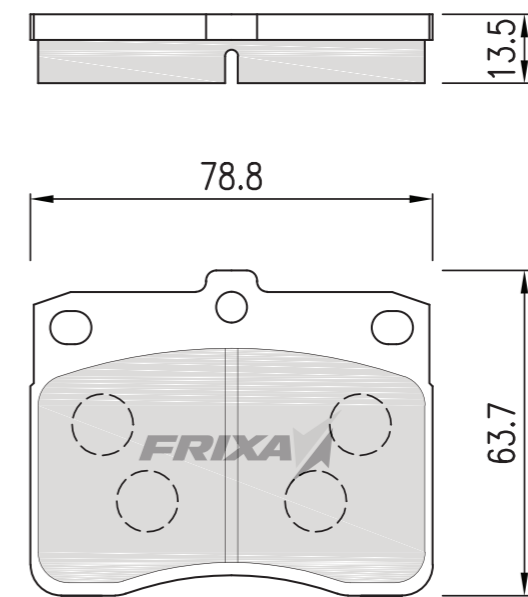

DISC BRAKE PAD

BRAKE SHOE ASSEMBLY

BRAKE LINING

DISC BRAKE PAD

BRAKE SHOE ASSEMBLY

BRAKE LINING

FRIXA CODE	MAKER	KIA	PART NUMBER		OK552-3323Z	
FPK13	REPRESENTATIVE MODEL	CARNIVAL	INTERCHANGEABLE		CARNIVAL OLD	
	PO	SP	WVA	FMSI	HP	TRW
	FRONT	SP1112	21822	D477-7338A	HP1011	GDB1153

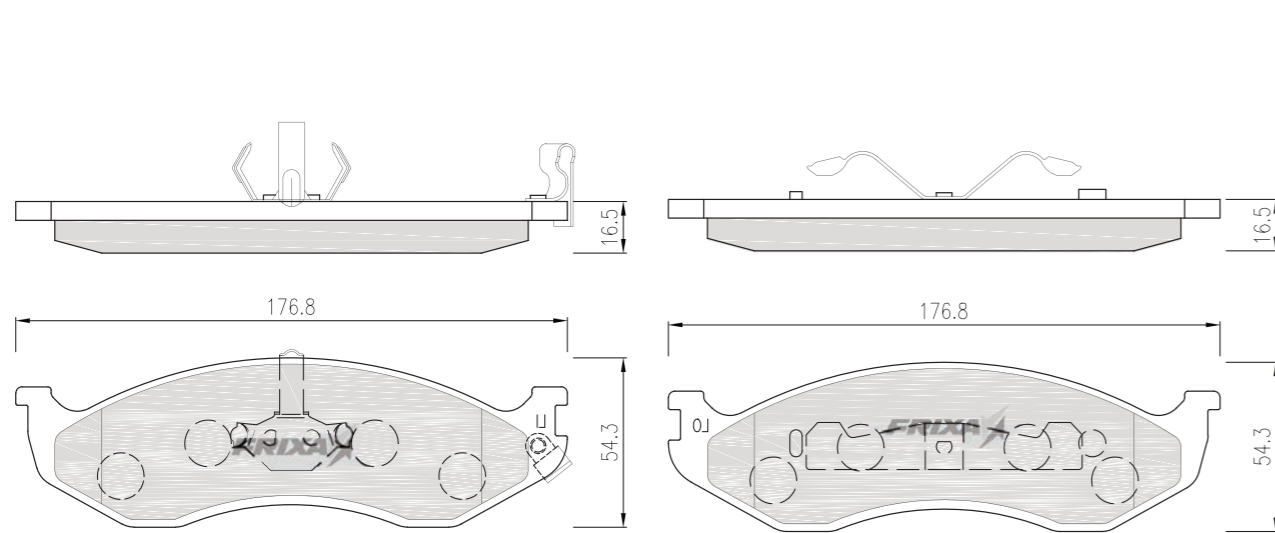

FRIXA CODE	MAKER	KIA	PART NUMBER		OK2FA-3328Z	
FPK14N	REPRESENTATIVE MODEL	CARENSII	INTERCHANGEABLE		CARENSII, X-TRECK	
	PO	SP	WVA	FMSI	HP	TRW
	FRONT	SP1162	23966		HP1020	GDB3342

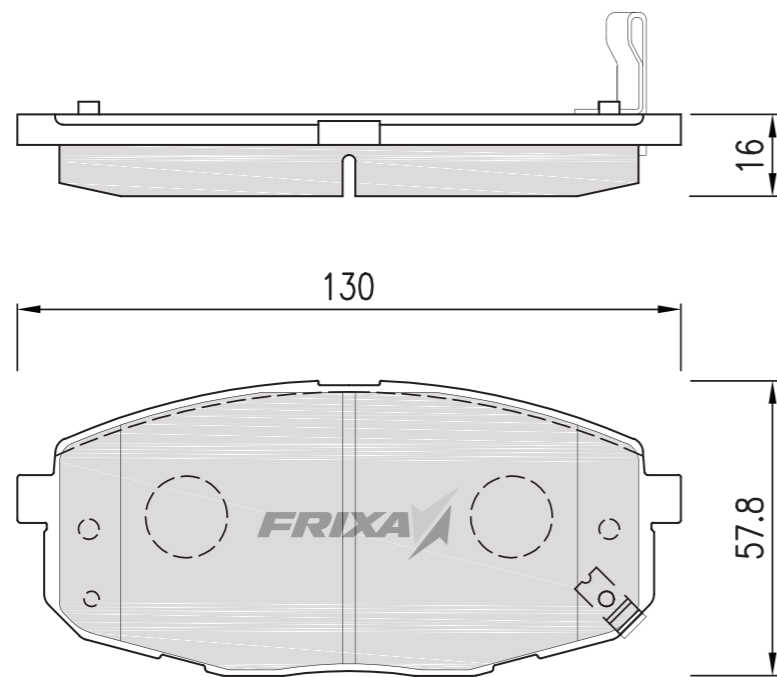

MAKER	KIA	PART NUMBER		58101-3ED00		FRIXA CODE
REPRESENTATIVE MODEL	SORENTO	INTERCHANGEABLE		SORENTO, FRONTIER 1.3		FPK15
PO	SP	WVA	FMSI	HP	TRW	
FRONT	SP1153	24092	D1301-8417	HP1017	GDB3452	

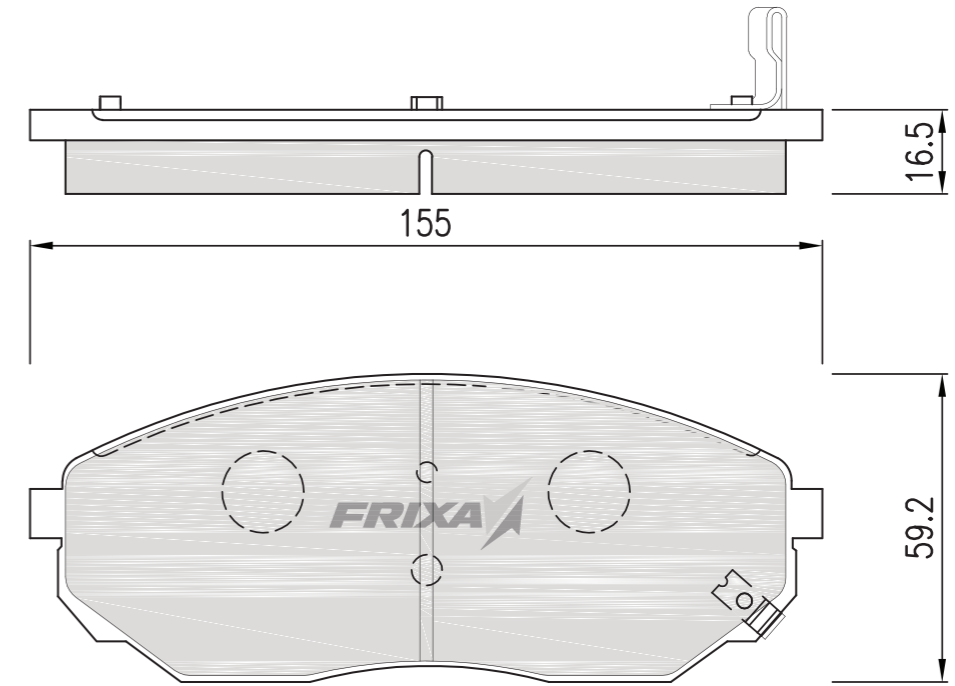

MAKER	KIA	PART NUMBER		OK40D-3328Z		FRIXA CODE
REPRESENTATIVE MODEL	FRONTIER 1.3	INTERCHANGEABLE		BONGO III 1.4TON PAMAX 1.4TON~3.5TON		FPK16
PO	SP	WVA	FMSI	HP	TRW	
FRONT	SP1148			HP1016		

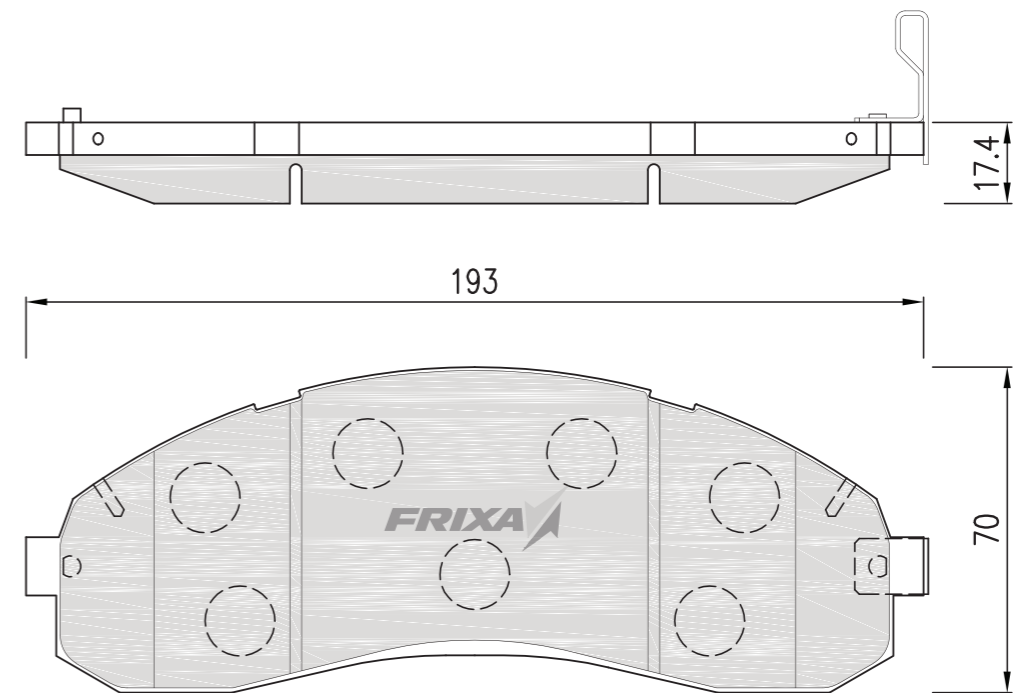

DISC BRAKE PAD

DISC BRAKE PAD

BRAKE SHOE ASSEMBLY

BRAKE SHOE ASSEMBLY

BRAKE LINING

BRAKE LINING

FRIXA CODE	MAKER	KIA	PART NUMBER		58101-17A10	
FPK17	REPRESENTATIVE MODEL	CERATO	INTERCHANGEABLE		CERATO 1.5(14"WHEEL), LAVITA NEW AVANTE XD1.5(ABS), AVANTE XD2.0 NEW AVANTE XD1.6	
	PO	SP	WVA	FMSI	HP	TRW
	FRONT	SP1152	24031	D941-7843	HP0027	GDB3378

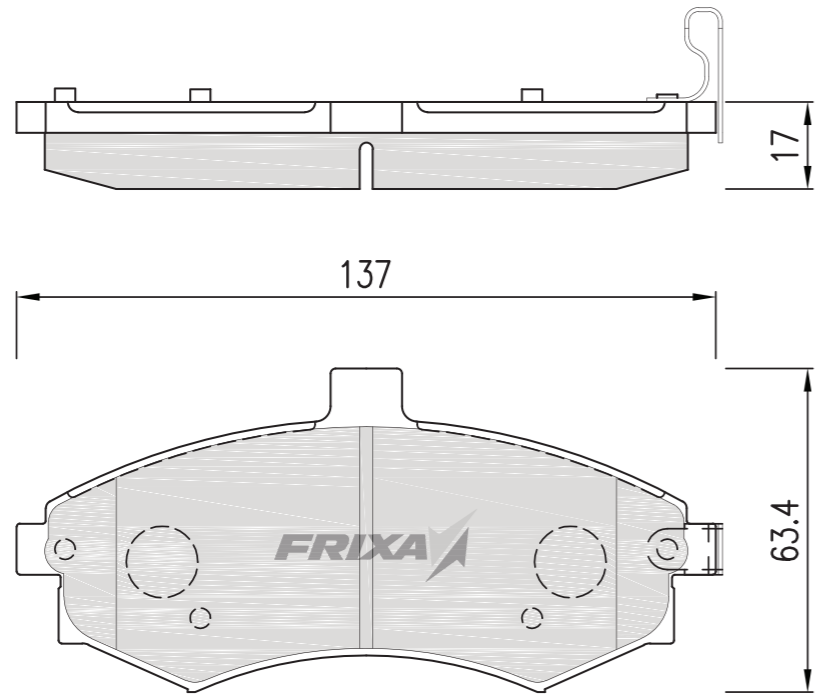

FRIXA CODE	MAKER	KIA	PART NUMBER		58101-2FA10	
FPK17N	REPRESENTATIVE MODEL	CERATO 15"	INTERCHANGEABLE		CERATO 2.0(15"WHEEL) NEW CERATO1.5(15"WHEEL)	
	PO	SP	WVA	FMSI	HP	TRW
	FRONT	SP1167	24218	D1074-7979	HP1031	GDB3367

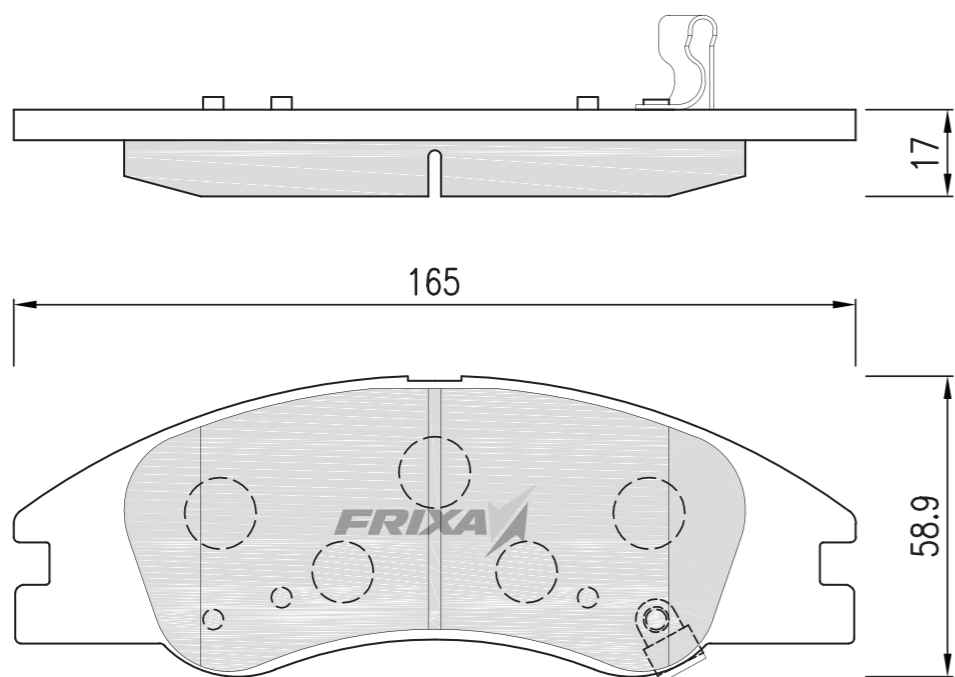

MAKER	KIA	PART NUMBER		58101-4EA00		FRIXA CODE
REPRESENTATIVE MODEL	BONGO III TRUCK	INTERCHANGEABLE		TRUCK		FPK18
PO	SP	WVA	FMSI	HP	TRW	
FRONT	SP1175			HP1023		

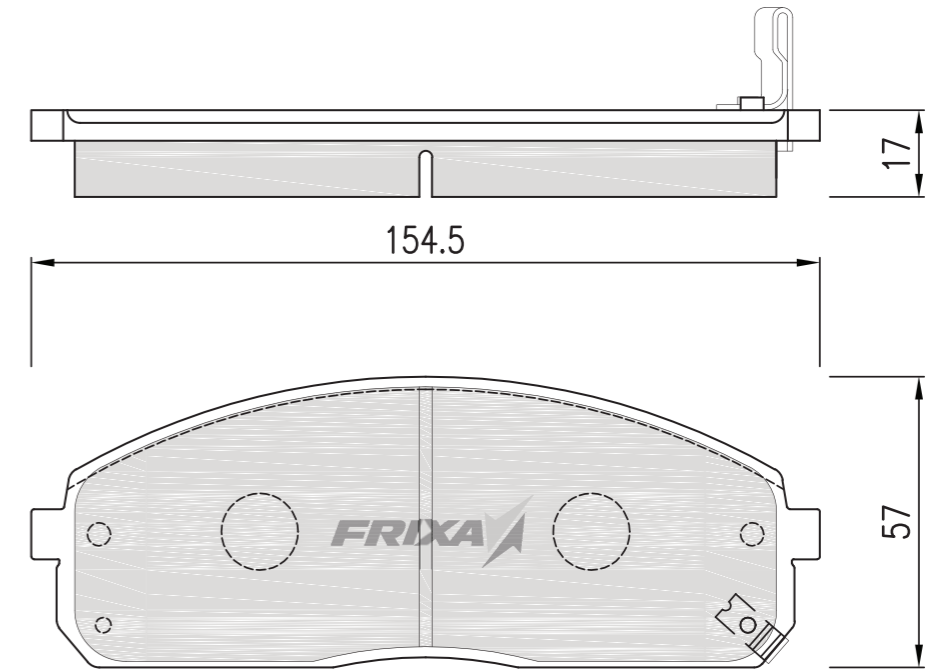

MAKER	KIA	PART NUMBER		58101-4EB00		FRIXA CODE
REPRESENTATIVE MODEL	BONGO III VAN	INTERCHANGEABLE		BONGO III COACH VAN		FPK19
PO	SP	WVA	FMSI	HP	TRW	
FRONT	SP1176			HP1024		

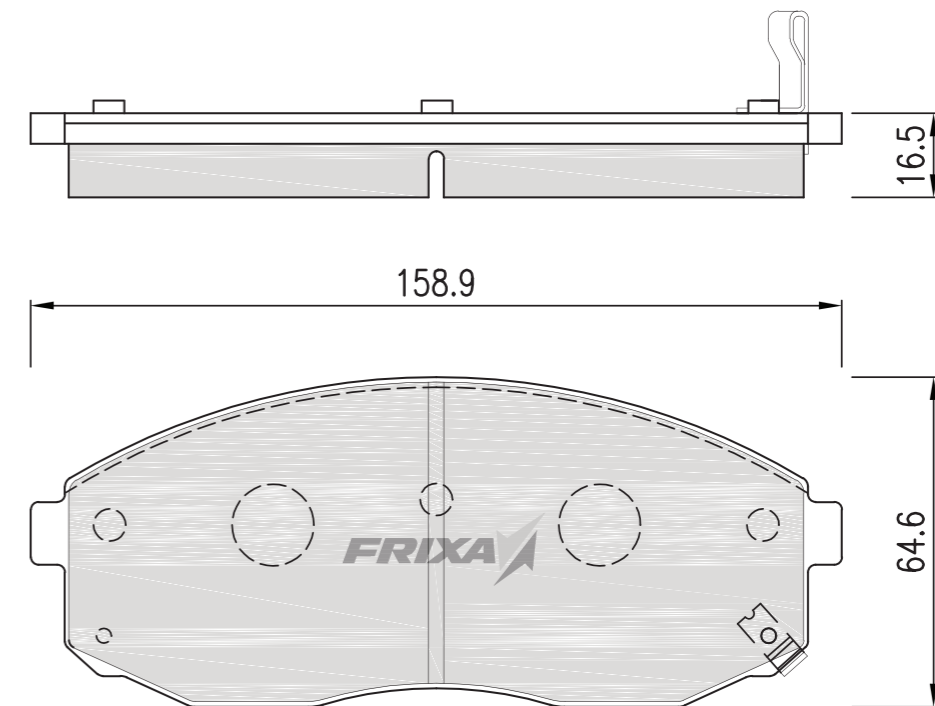

DISC BRAKE PAD

BRAKE SHOE ASSEMBLY

BRAKE LINING

DISC BRAKE PAD

BRAKE SHOE ASSEMBLY

BRAKE LINING

FRIXA CODE	MAKER	KIA	PART NUMBER		58101-07A00	
FPK20	REPRESENTATIVE MODEL	MORNING	INTERCHANGEABLE	MORNING		
	PO	SP	WVA	FMSI	HP	TRW
	FRONT	SP1172	24275		HP1025	

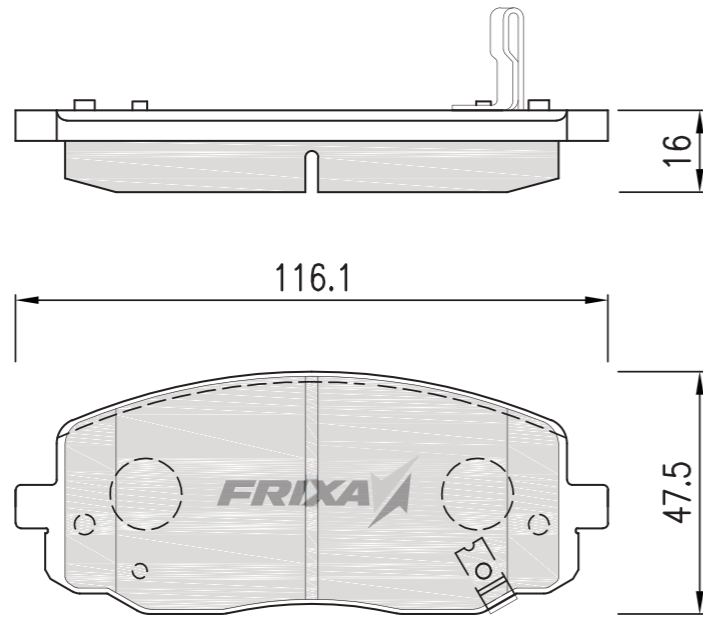

FRIXA CODE	MAKER	KIA	PART NUMBER		58101-4DE00	
FPK21	REPRESENTATIVE MODEL	NEW CARNIVAL	INTERCHANGEABLE	GRAND CARNIVAL(16"WHEEL) GRAND STAREX		
	PO	SP	WVA	FMSI	HP	TRW
	FRONT	SP1238	24598			GDB3448

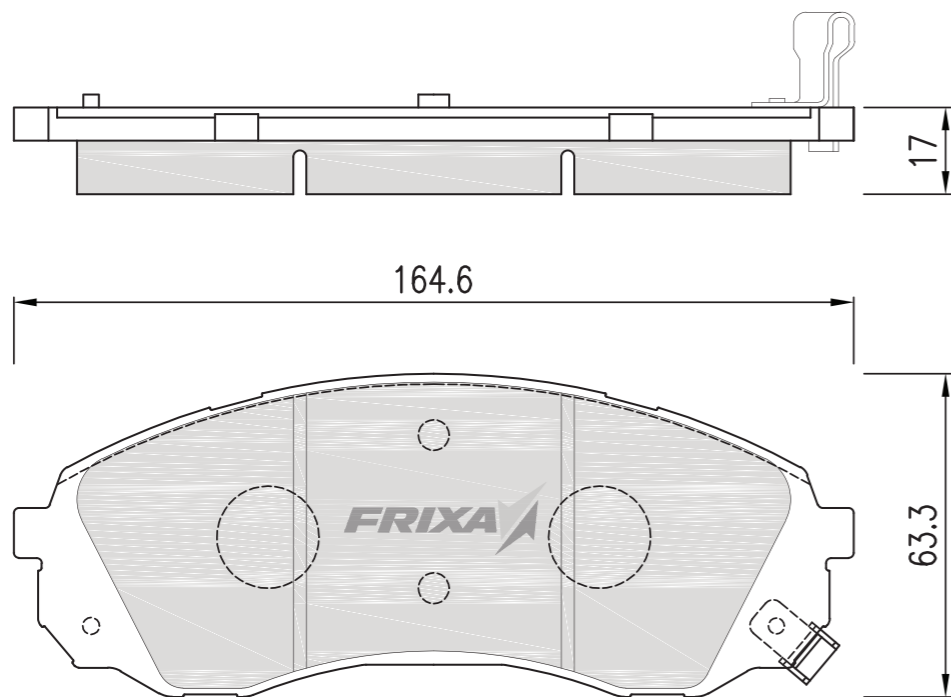

MAKER	KIA	PART NUMBER		58101-4DA00		FRIXA CODE
REPRESENTATIVE MODEL	GRAND CARNIVAL	INTERCHANGEABLE	GRAND CARNIVAL17"			FPK22
PO	SP	WVA	FMSI	HP	TRW	
FRONT	SP1191					

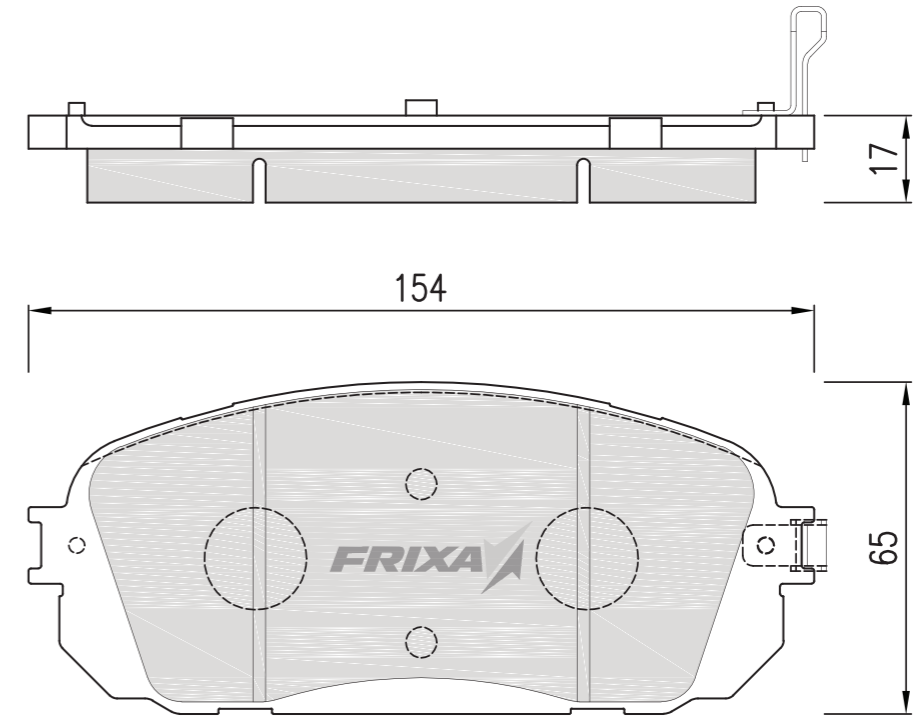

MAKER	KIA	PART NUMBER		0K95B-3328Z		FRIXA CODE
REPRESENTATIVE MODEL	ENTERPRISES	INTERCHANGEABLE	ENTERPRISES			FPK23
PO	SP	WVA	FMSI	HP	TRW	
FRONT	SP1145			HP1030		

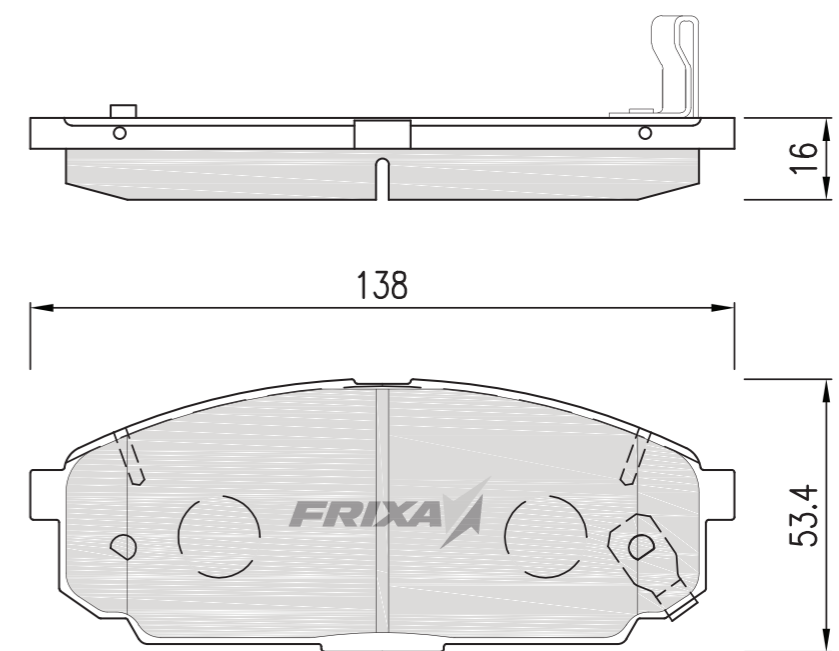

DISC BRAKE PAD

BRAKE SHOE ASSEMBLY

BRAKE LINING

DISC BRAKE PAD

BRAKE SHOE ASSEMBLY

BRAKE LINING

FRIXA CODE	MAKER	KIA	PART NUMBER		58115-FDA00	
FPK24	REPRESENTATIVE MODEL	RIO SF 1.3	INTERCHANGEABLE		RIO SF 1.3(13"WHEEL)	
	PO	SP	WVA	FMSI	HP	TRW
	FRONT	SP1164			HP1022	

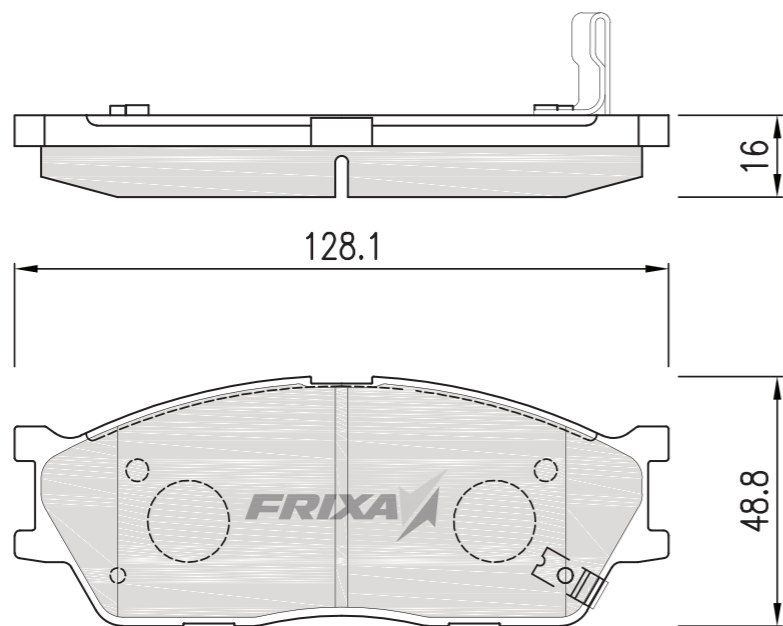

FRIXA CODE	MAKER	KIA	PART NUMBER		58101-1DA00	
FPK25	REPRESENTATIVE MODEL	NEW CARENS 06MY	INTERCHANGEABLE		NEWCARENS, TUCSON IX 2WD	
	PO	SP	WVA	FMSI	HP	TRW
	FRONT	SP1196	24501	D1295-8614		

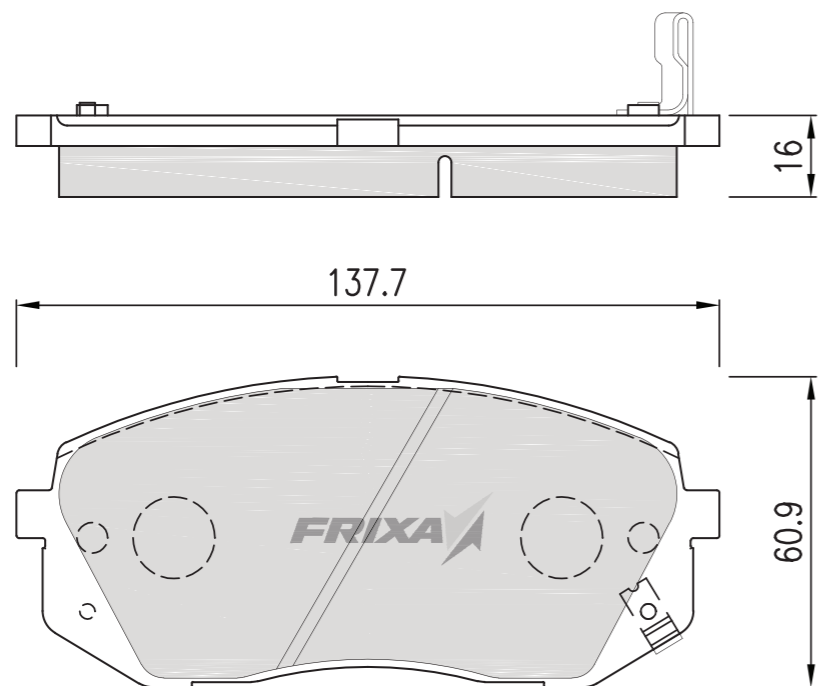

MAKER	KIA	PART NUMBER		58101-2JA00		FRIXA CODE
REPRESENTATIVE MODEL	MOHAVE	INTERCHANGEABLE		MOHAVE		FPK26
PO	SP	WVA	FMSI	HP	TRW	
FRONT	SP1248					

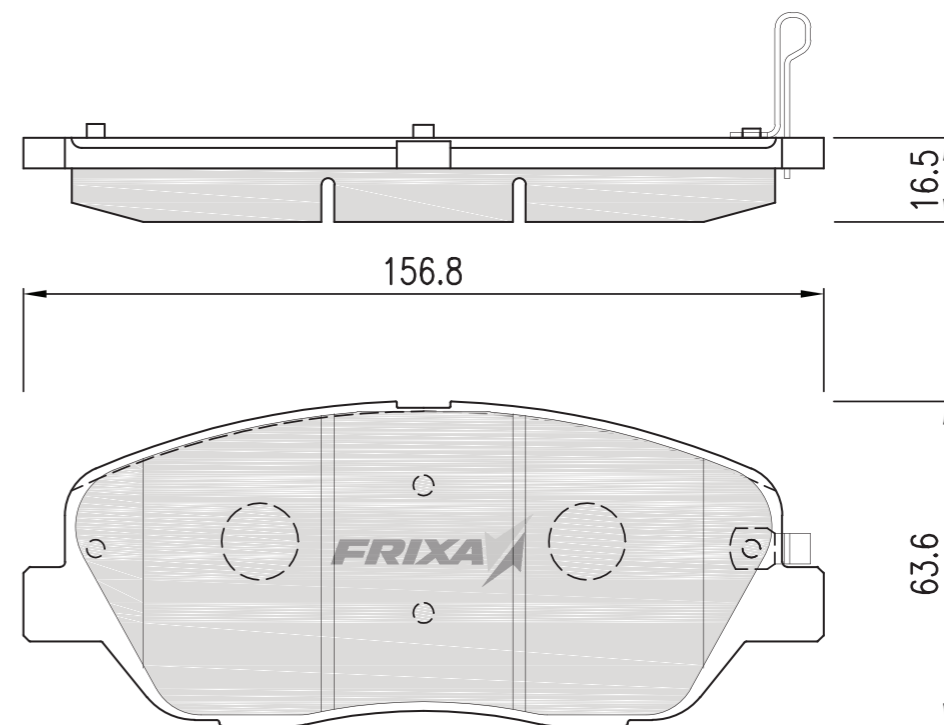

MAKER	KIA	PART NUMBER		58101-2TA00		FRIXA CODE
REPRESENTATIVE MODEL	K5 2.0	INTERCHANGEABLE		K5 2.0		FPK27
PO	SP	WVA	FMSI	HP	TRW	
FRONT						

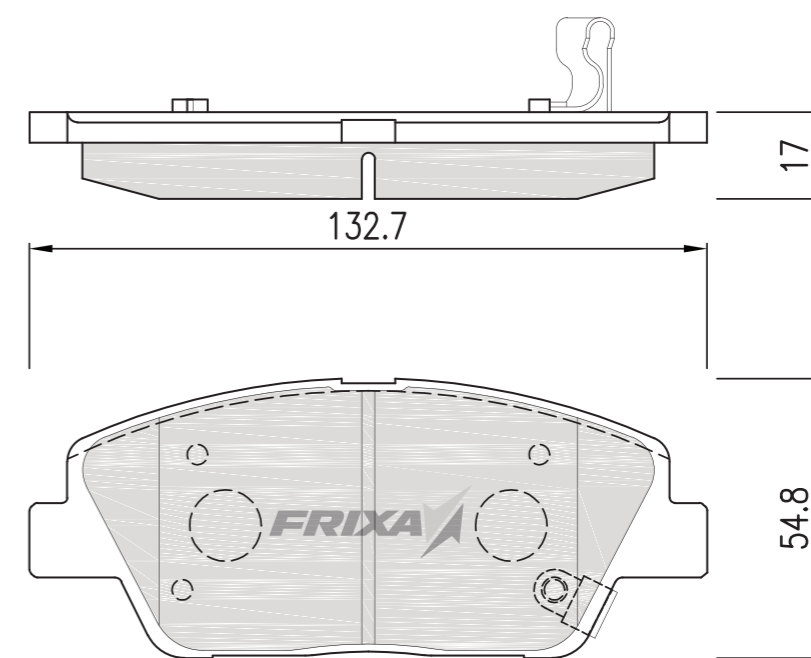

DISC BRAKE PAD

BRAKE SHOE ASSEMBLY

BRAKE LINING

DISC BRAKE PAD

BRAKE SHOE ASSEMBLY

BRAKE LINING

FRIXA CODE	MAKER	KIA	PART NUMBER		58101-3QA10	
FPK28	REPRESENTATIVE MODEL	K5 2.4	INTERCHANGEABLE		K5 2.4	
	PO	SP	WVA	FMSI	HP	TRW
	FRONT					

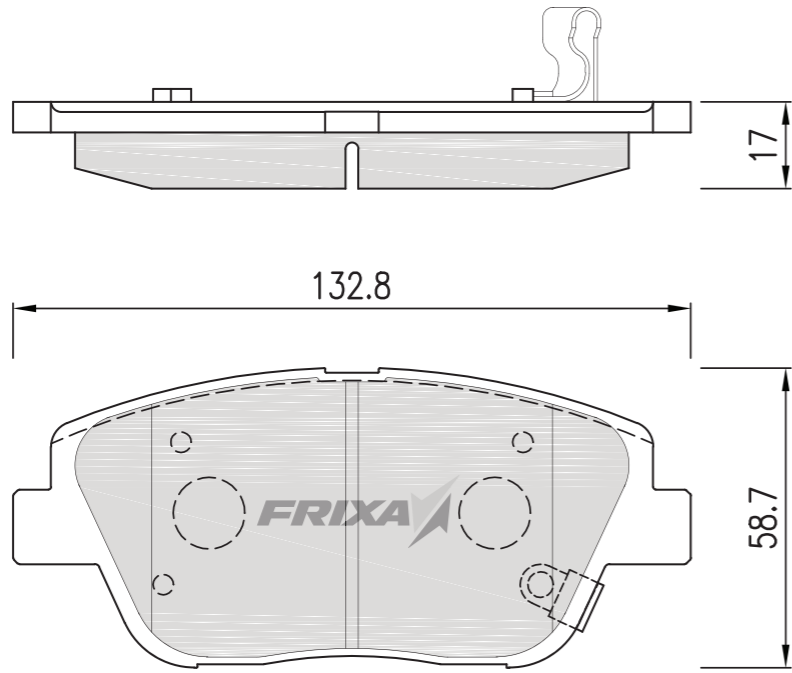

FRIXA CODE	MAKER	KIA	PART NUMBER		58302-1GA00	
FPK01NR	REPRESENTATIVE MODEL	PRIDE(NEW)	INTERCHANGEABLE		PRIDE 05MY, VERNA 05MY i-30, YF SONATA, TUCSON IX	
	PO	SP	WVA	FMSI	HP	TRW
	REAR	SP1187	24320	D1157-8267		GDB3421

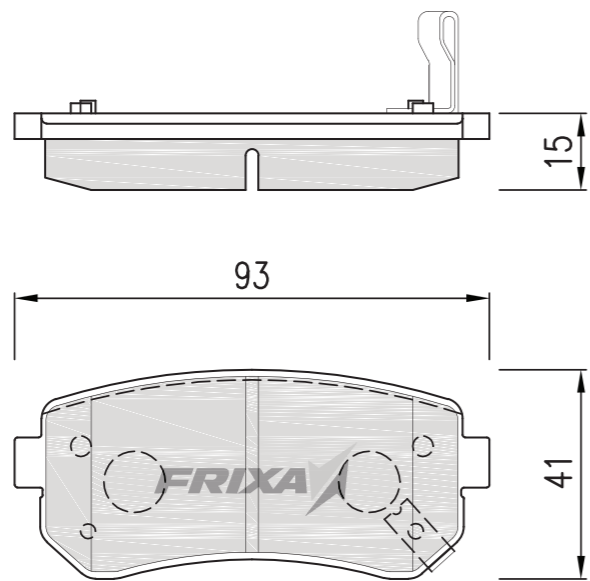

MAKER	KIA	PART NUMBER		OK2FA-2628Z		FRIXA CODE
REPRESENTATIVE MODEL	CREDOS	INTERCHANGEABLE		SEPHIA II, SHUMA, CREDOS I / II SPECTRA, CARENS I / II		FPK04R
PO	SP	WVA	FMSI	HP	TRW	
REAR	SP1079-R	23455	D775-7642	HP1009	GDB3203	

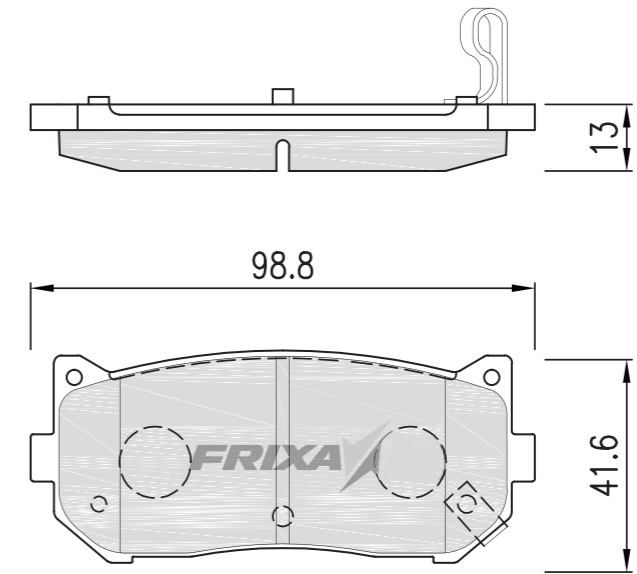

MAKER	KIA	PART NUMBER		0HF39-2648Z		FRIXA CODE
REPRESENTATIVE MODEL	POTENSIA	INTERCHANGEABLE		POTENSIA(NEW)		FPK06R
PO	SP	WVA	FMSI	HP	TRW	
REAR	SP1084			HP1006		

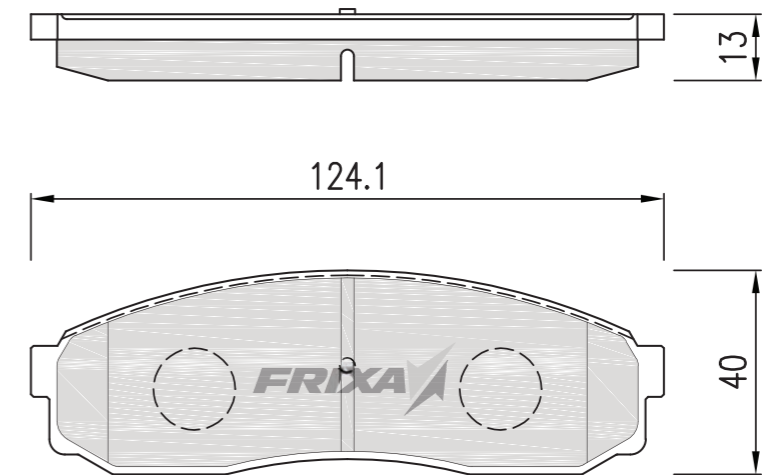

DISC BRAKE PAD

BRAKE SHOE ASSEMBLY

BRAKE LINING

DISC BRAKE PAD

BRAKE SHOE ASSEMBLY

BRAKE LINING

FRIXA CODE	MAKER	KIA	PART NUMBER		58302-3ED00	
REPRESENTATIVE MODEL	SORENTO	INTERCHANGEABLE		SORENTO		
FPK15R	PO	SP	WVA	FMSI	HP	TRW
	REAR	SP1154	23997	D1261-8379	HP1018	GDB3344

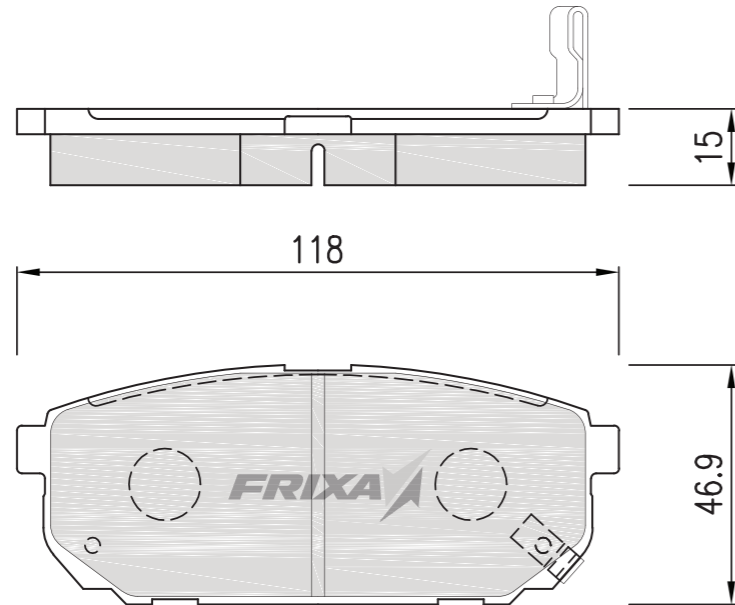

FRIXA CODE	MAKER	KIA	PART NUMBER		58302-07A00	
REPRESENTATIVE MODEL	MORNING	INTERCHANGEABLE		MORNING		
FPK20R	PO	SP	WVA	FMSI	HP	TRW
	REAR	SP1189	24276			

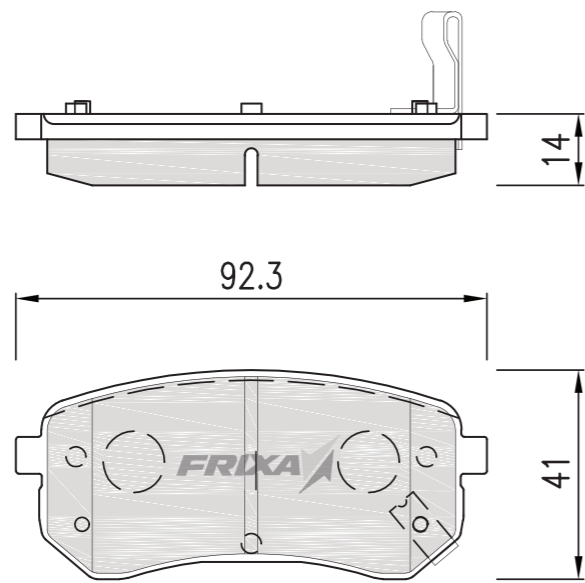

MAKER	KIA	PART NUMBER		58302-1DA00		FRIXA CODE
REPRESENTATIVE MODEL	NEW CARENS	INTERCHANGEABLE		NEW CARENS		
FPK25R	PO	SP	WVA	FMSI	HP	TRW
	REAR	SP1197	24491	D1296-8413		

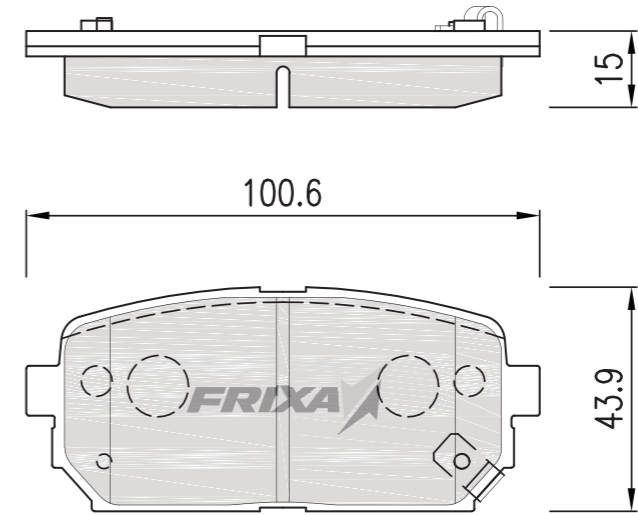

MAKER	KIA	PART NUMBER		58302-2JA00		FRIXA CODE
REPRESENTATIVE MODEL	MOHAVE	INTERCHANGEABLE		MOHAVE, GENESIS, CHAIRMAN W EQUUS NEW, SORENTO R		
FPK26R	PO	SP	WVA	FMSI	HP	TRW
	REAR	SP1247		D1387-8496		

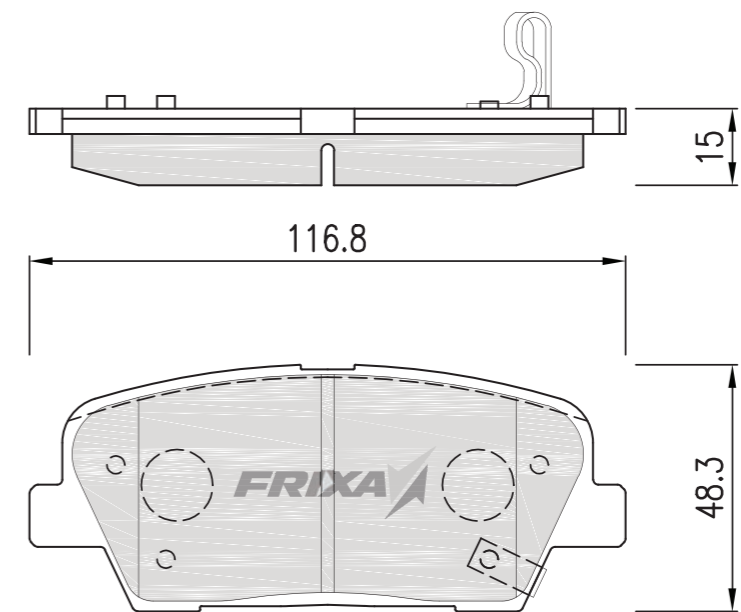

DISC BRAKE PAD

BRAKE SHOE ASSEMBLY

BRAKE LINING

DISC BRAKE PAD

BRAKE SHOE ASSEMBLY

BRAKE LINING

FRIXA CODE	MAKER	KIA	PART NUMBER		K5 2.0	
FPK27R	REPRESENTATIVE MODEL	K5 2.0	INTERCHANGEABLE		K5 2.0	
	PO	SP	WVA	FMSI	HP	TRW
	REAR	SP1239		D1313-8428		

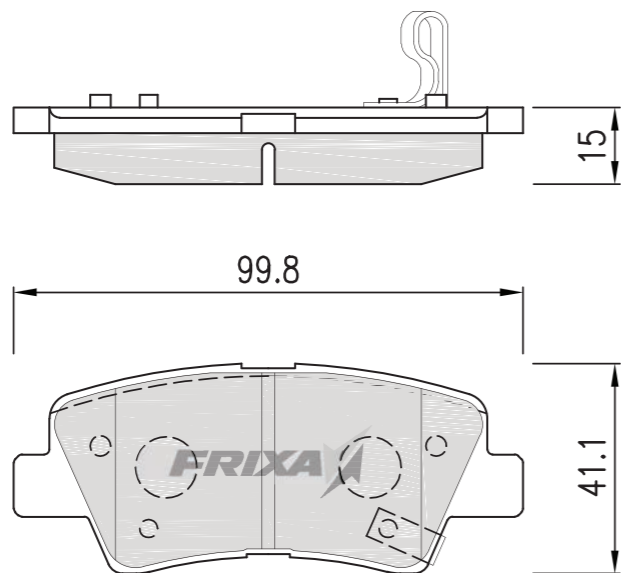

FRIXA CODE	MAKER	CHEVROLET (GM-DAEWOO)	PART NUMBER		52210-70B00	
FPD01	REPRESENTATIVE MODEL	TICO	INTERCHANGEABLE		TICO	
	PO	SP	WVA	FMSI	HP	TRW
	FRONT	SP1050	23061		HP2001	GDB3108

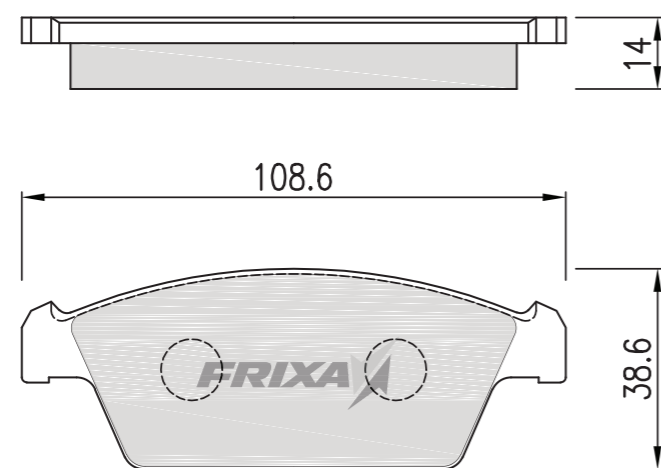

MAKER	CHEVROLET (GM-DAEWOO)	PART NUMBER		90297552		FRIXA CODE
REPRESENTATIVE MODEL	LEMANS	INTERCHANGEABLE		LEMANS, ROYAL PRINCE BROUGHAM		FPD02
PO	SP	WVA	FMSI	HP	TRW	
FRONT	SP1055	20939	D378-7267	HP2003	GDB199	

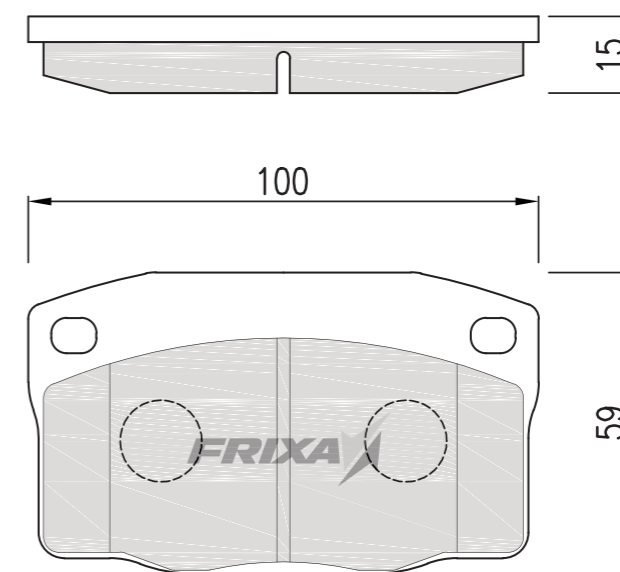

MAKER	CHEVROLET (GM-DAEWOO)	PART NUMBER		90297552		FRIXA CODE
REPRESENTATIVE MODEL	ESPERO1.5	INTERCHANGEABLE		ESPERO1.5, CIELO, NEXIA		FPD03
PO	SP	WVA	FMSI	HP	TRW	
FRONT	SP1055	20939	D378-7267	HP2003	GDB199	

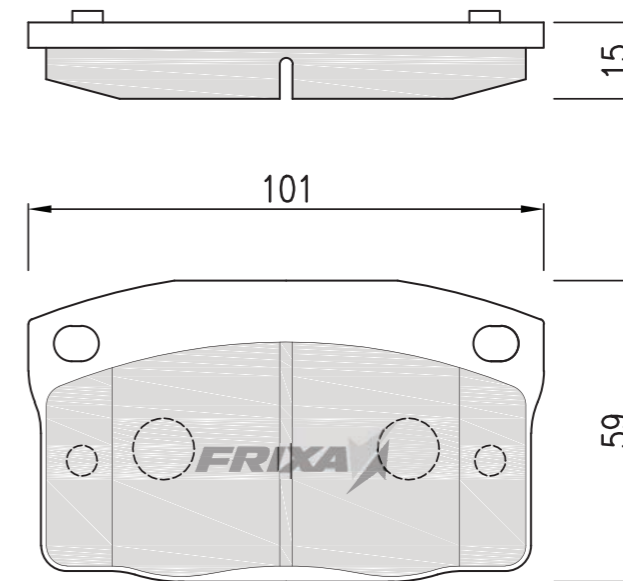

DISC BRAKE PAD

BRAKE SHOE ASSEMBLY

BRAKE LINING

DISC BRAKE PAD

BRAKE SHOE ASSEMBLY

BRAKE LINING

FRIXA CODE	MAKER	CHEVROLET (GM-DAEWOO)	PART NUMBER	11046952012		
FPD05	REPRESENTATIVE MODEL	ESPERO2.0	INTERCHANGEABLE	ESPERO2.0(TEVESE) PRINCE(TEVESE)		
	PO	SP	WVA	FMSI	HP	TRW
	FRONT	SP1078	21190	D796-7666	HP2004	GDB951

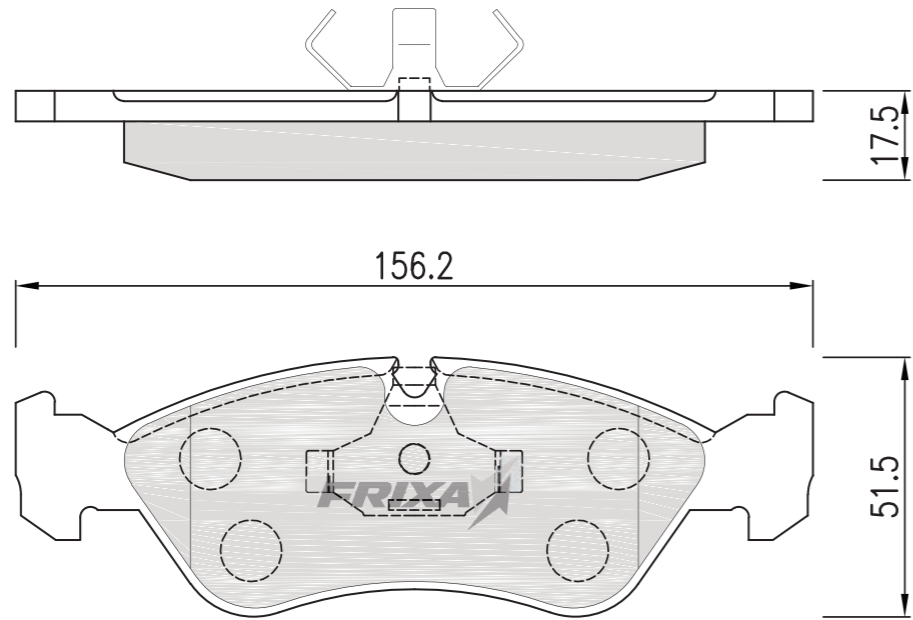

FRIXA CODE	MAKER	CHEVROLET (GM-DAEWOO)	PART NUMBER	96245178		
FPD06	REPRESENTATIVE MODEL	NEW PRINCE	INTERCHANGEABLE	NEW PRINCE, LANOS DOHC BROUGHAM NEW		
	PO	SP	WVA	FMSI	HP	TRW
	FRONT	SP1077			HP2005	GDB7583

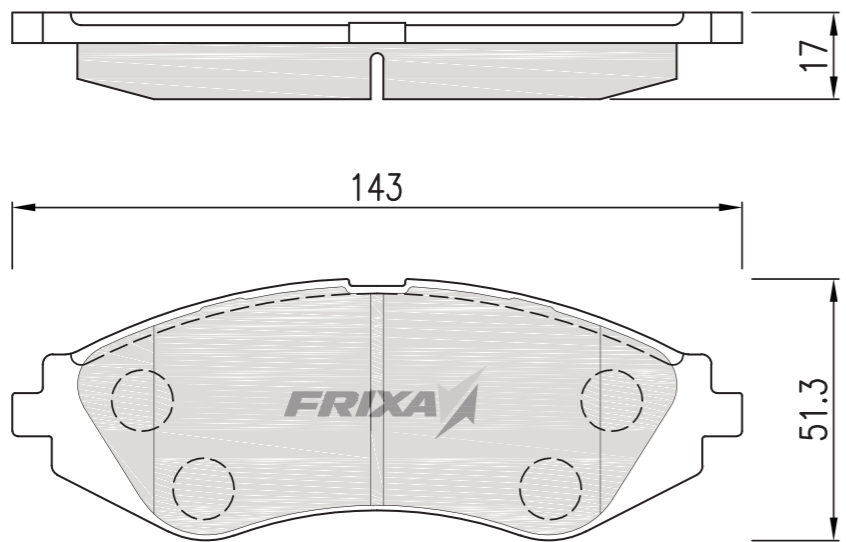

MAKER	CHEVROLET (GM-DAEWOO)	PART NUMBER	45022-SA0N50			FRIXA CODE
REPRESENTATIVE MODEL	DAMAS	INTERCHANGEABLE	DAMAS, DAMAS II, LABO			FPD07
PO	SP	WVA	FMSI	HP	TRW	
FRONT	SP1059	20731	D177-7104	HP2013	GDB254	

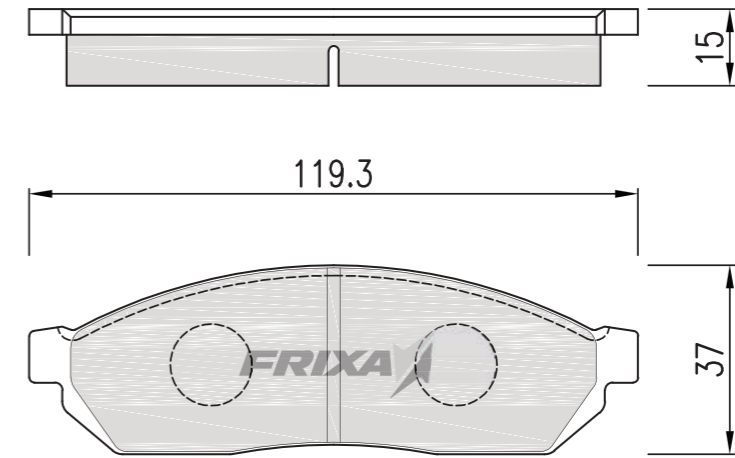

MAKER	CHEVROLET (GM-DAEWOO)	PART NUMBER	96245178			FRIXA CODE
REPRESENTATIVE MODEL	LEGANZA	INTERCHANGEABLE	LEGANZA, NUBIRA DOHC NUBIRA II			FPD08
PO	SP	WVA	FMSI	HP	TRW	
FRONT	SP1102	23234	7667-D797	HP2006	GDB3216	

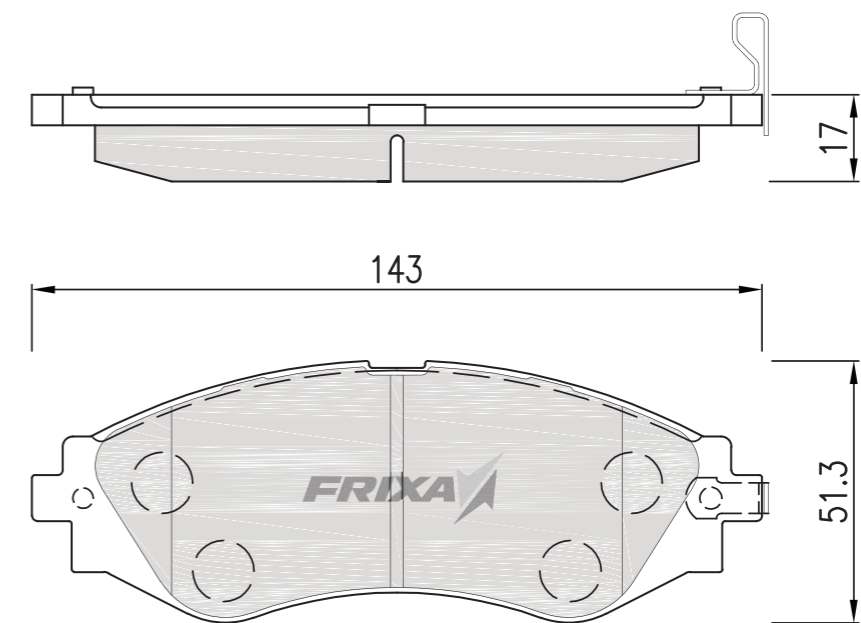

DISC BRAKE PAD

BRAKE SHOE ASSEMBLY

BRAKE LINING

DISC BRAKE PAD

BRAKE SHOE ASSEMBLY

BRAKE LINING

FRIXA CODE	MAKER	CHEVROLET (GM-DAEWOO)	PART NUMBER	96273708		
FPD09	REPRESENTATIVE MODEL	LANOS	INTERCHANGEABLE	LANOS SOHC, MATIZ I /II/III		
	PO	SP	WVA	FMSI	HP	TRW
	FRONT	SP1086	23241	8433-D1321	HP2002	GDB3195

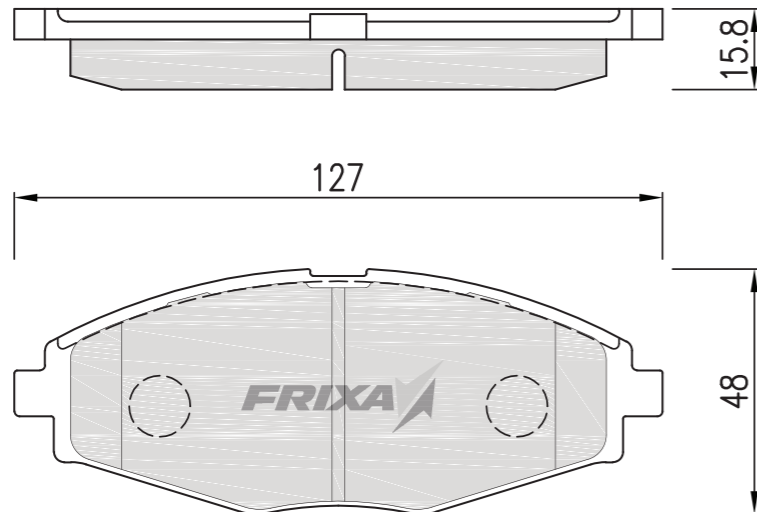

FRIXA CODE	MAKER	CHEVROLET (GM-DAEWOO)	PART NUMBER	96349059		
FPD10	REPRESENTATIVE MODEL	MAGNUS	INTERCHANGEABLE	MAGNUS, MAGNUS L6 2.0 REZZO		
	PO	SP	WVA	FMSI	HP	TRW
	FRONT	SP1103	24062		HP2008	GDB3345

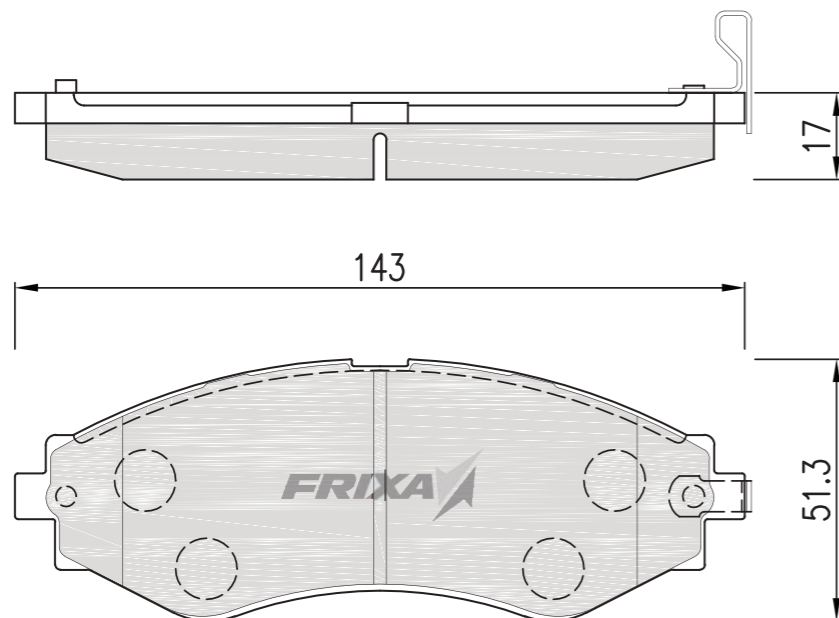

MAKER	CHEVROLET (GM-DAEWOO)	PART NUMBER	55200-85Z00			FRIXA CODE
REPRESENTATIVE MODEL	LACETTI	INTERCHANGEABLE	LACETTI, GENTRA X (14" WHEEL)			FPD12
PO	SP	WVA	FMSI	HP	TRW	
FRONT	SP1159	23234	D902-7779	HP2012	GDB3171	

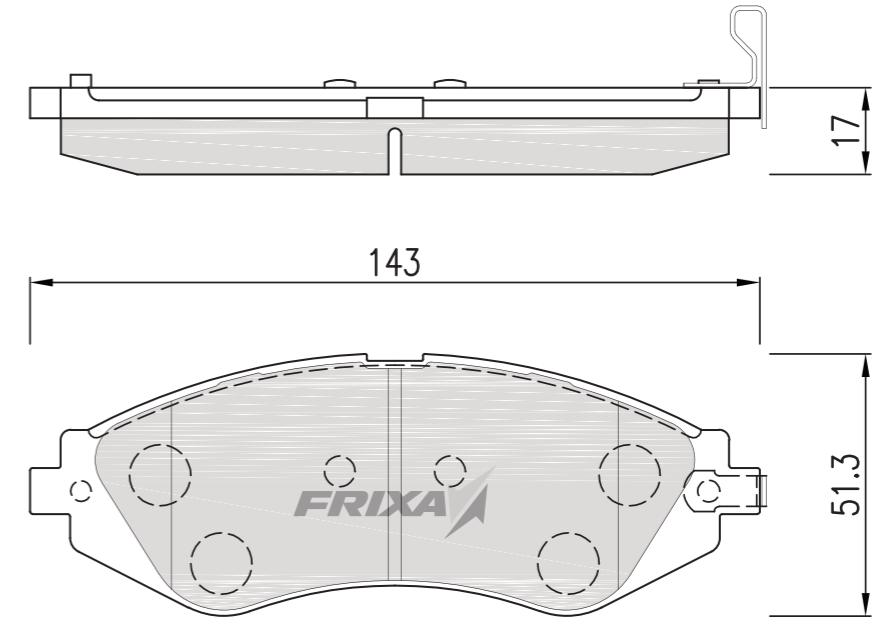

MAKER	CHEVROLET (GM-DAEWOO)	PART NUMBER	94566892			FRIXA CODE
REPRESENTATIVE MODEL	KALOS	INTERCHANGEABLE	KALOS, GENTRA X (13" WHEEL) GENTRA, NUBIRA SOHC			FPD13
PO	SP	WVA	FMSI	HP	TRW	
FRONT	SP1158	23974	D1269-8385	HP2011	GDB3330	

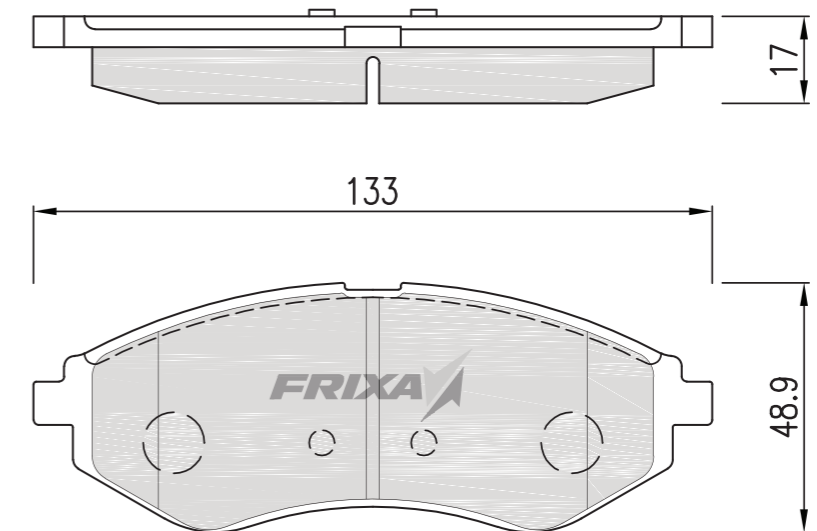

DISC BRAKE PAD

BRAKE SHOE ASSEMBLY

BRAKE LINING

DISC BRAKE PAD

BRAKE SHOE ASSEMBLY

BRAKE LINING

FRIXA CODE	MAKER	CHEVROLET (GM-DAEWOO)	PART NUMBER	96475026		
FPD14	REPRESENTATIVE MODEL	TOSCA	INTERCHANGEABLE	TOSCA, MAGNUS L6 2.5		
	PO	SP	WVA	FMSI	HP	TRW
	FRONT	SP1193		D1031-7936		

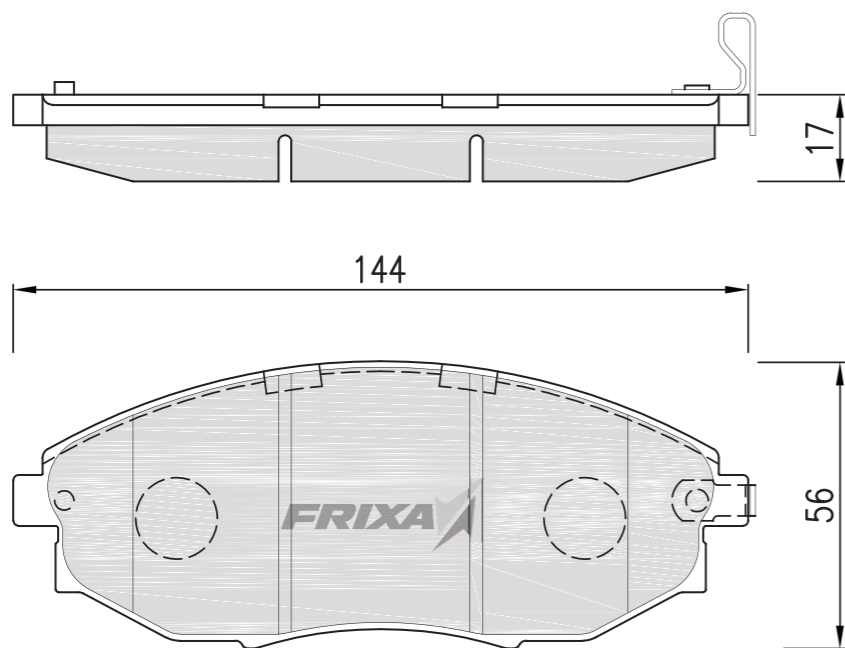

FRIXA CODE	MAKER	CHEVROLET (GM-DAEWOO)	PART NUMBER	45022-S10A00		
FPD15	REPRESENTATIVE MODEL	ACARDIA	INTERCHANGEABLE	ACARDIA		
	PO	SP	WVA	FMSI	HP	TRW
	FRONT	SP1076-F	21651	D503-7382	HP2010	GDB995

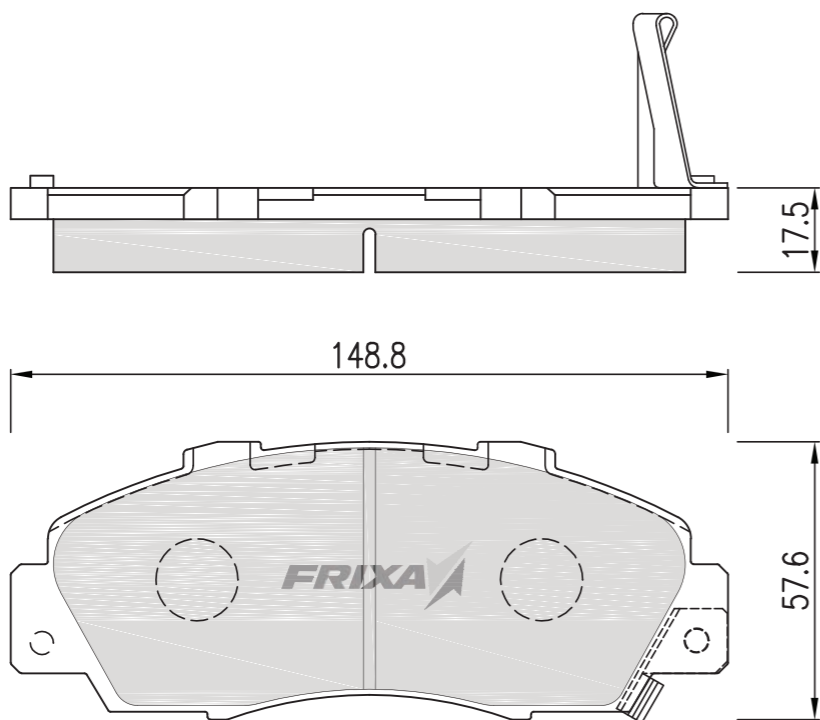

MAKER	CHEVROLET (GM-DAEWOO)	PART NUMBER	96626069			FRIXA CODE
REPRESENTATIVE MODEL	WINSTORM	INTERCHANGEABLE	WINSTORM			FPD16
PO	SP	WVA	FMSI	HP	TRW	
FRONT	SP1204	24510	8381-D1264		GDB1715	

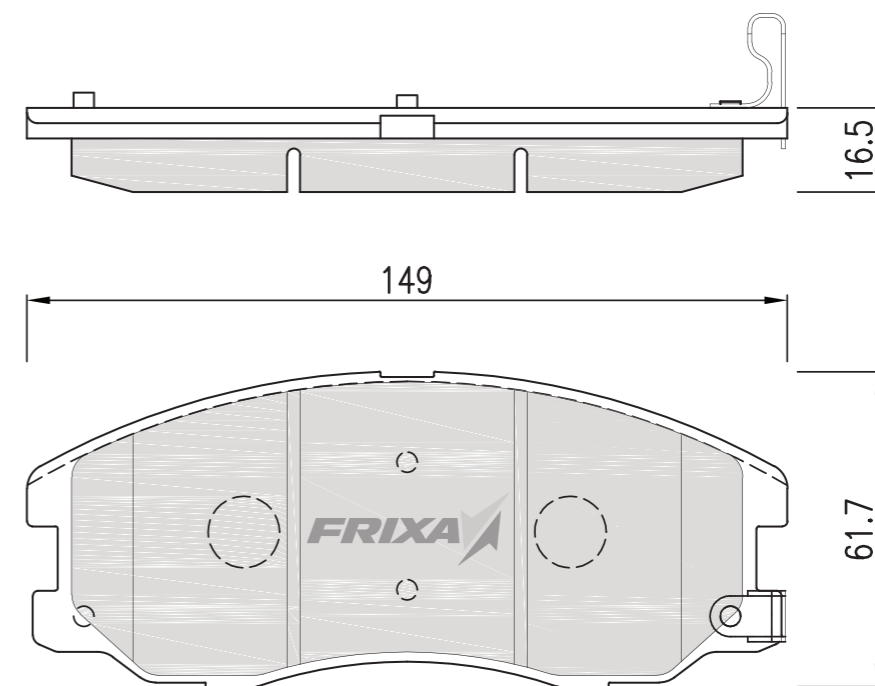

MAKER	CHEVROLET (GM-DAEWOO)	PART NUMBER	13301208			FRIXA CODE
REPRESENTATIVE MODEL	LACETTI PREMIERE	INTERCHANGEABLE	LACETTI PREMIERE			FPD17
PO	SP	WVA	FMSI	HP	TRW	
FRONT	SP1362					

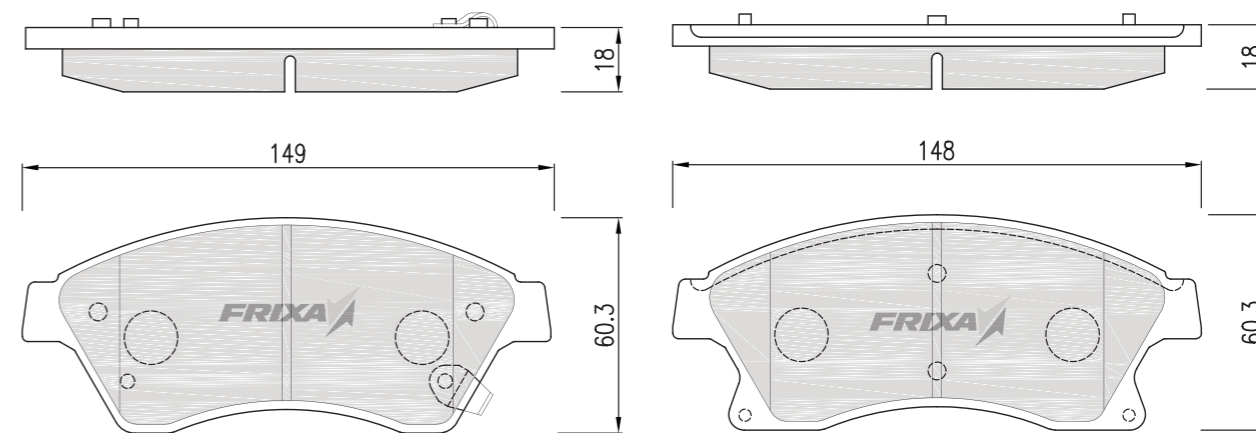

DISC BRAKE PAD

DISC BRAKE PAD

BRAKE SHOE ASSEMBLY

BRAKE SHOE ASSEMBLY

BRAKE LINING

BRAKE LINING

FRIXA CODE	MAKER	CHEVROLET (GM-DAEWOO)	PART NUMBER	P94564512		
FPD18	REPRESENTATIVE MODEL	MATIZ CREATIVE	INTERCHANGEABLE	MATIZ CREATIVE		
	PO	SP	WVA	FMSI	HP	TRW
	FRONT					

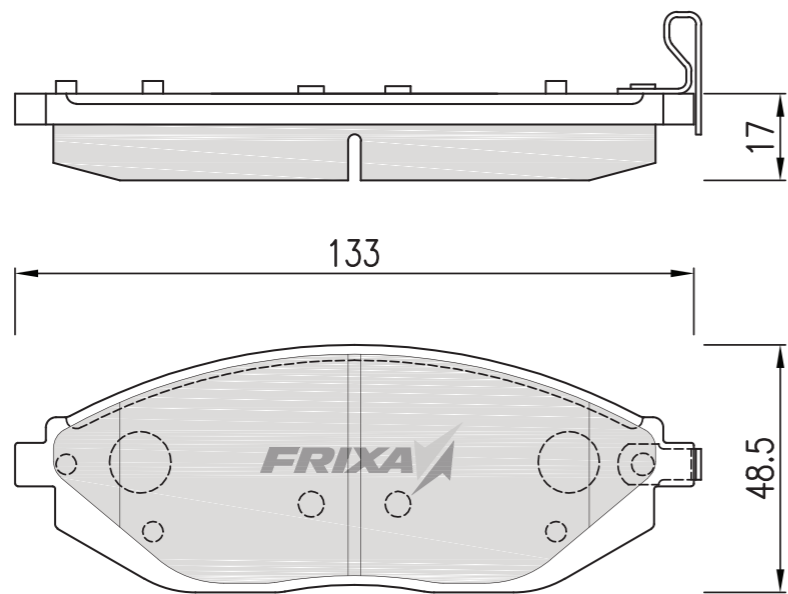

FRIXA CODE	MAKER	CHEVROLET (GM-DAEWOO)	PART NUMBER	96245179		
FPD08R	REPRESENTATIVE MODEL	LEGANZA	INTERCHANGEABLE	LEGANZA, NUBIRA		
	PO	SP	WVA	FMSI	HP	TRW
	REAR	SP1114	23237	D724-7591	HP2007	GDB3172

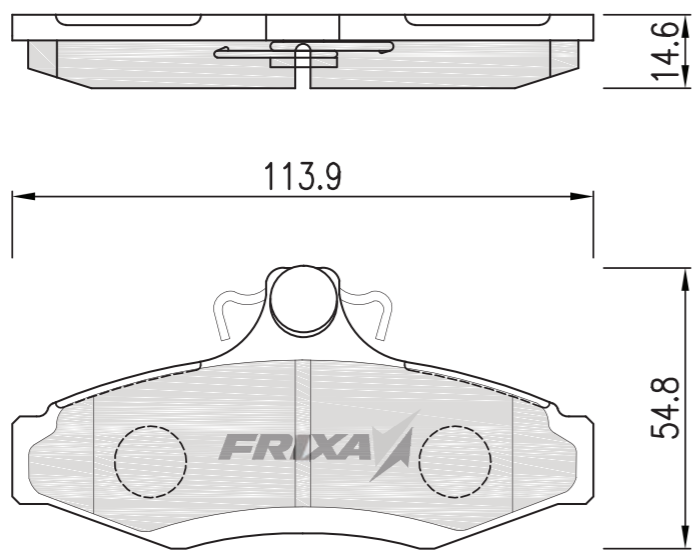

MAKER	CHEVROLET (GM-DAEWOO)	PART NUMBER	55500-86Z00			FRIXA CODE
REPRESENTATIVE MODEL	MAGNUS	INTERCHANGEABLE	MAGNUS, TOSCA			FPD10R
PO	SP	WVA	FMSI	HP	TRW	
REAR	SP1252	23994	D1030-7935	HP2009	GDB3346	

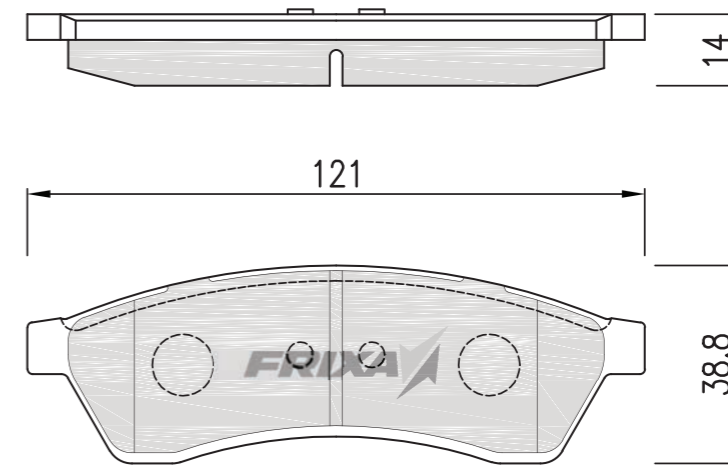

MAKER	CHEVROLET (GM-DAEWOO)	PART NUMBER	55500-85Z00			FRIXA CODE
REPRESENTATIVE MODEL	LACETTI	INTERCHANGEABLE	LACETTI			FPD12R
PO	SP	WVA	FMSI	HP	TRW	
REAR	SP1160	24071	D1036-7939	HP1024	GDB3348	

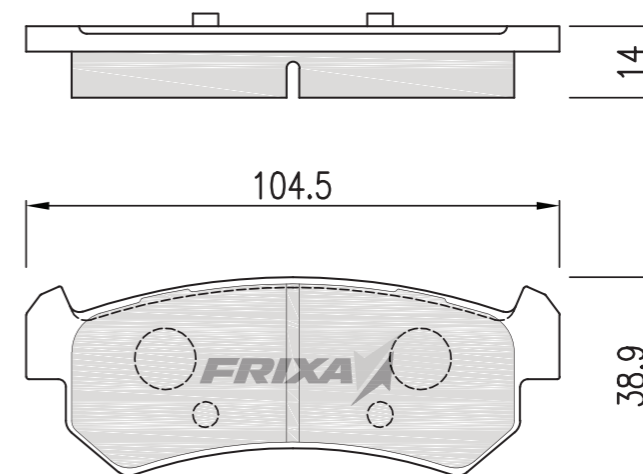

DISC BRAKE PAD

BRAKE SHOE ASSEMBLY

BRAKE LINING

DISC BRAKE PAD

BRAKE SHOE ASSEMBLY

BRAKE LINING

FRIXA CODE	MAKER	CHEVROLET (GM-DAEWOO)	PART NUMBER	55500-85Z10		
FPD12NR	REPRESENTATIVE MODEL	LACETTI 06MY	INTERCHANGEABLE	LACETTI 06MY		
	PO	SP	WVA	FMSI	HP	TRW
	REAR	SP1257				

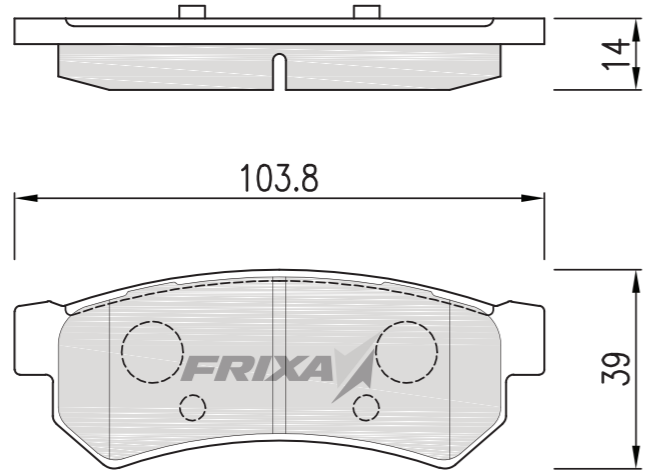

FRIXA CODE	MAKER	CHEVROLET (GM-DAEWOO)	PART NUMBER	19149904		
FPD16R	REPRESENTATIVE MODEL	WINSTORM R	INTERCHANGEABLE			
	PO	SP	WVA	FMSI	HP	TRW
	REAR	SP1205	24498	D1275-8391		GDB1716

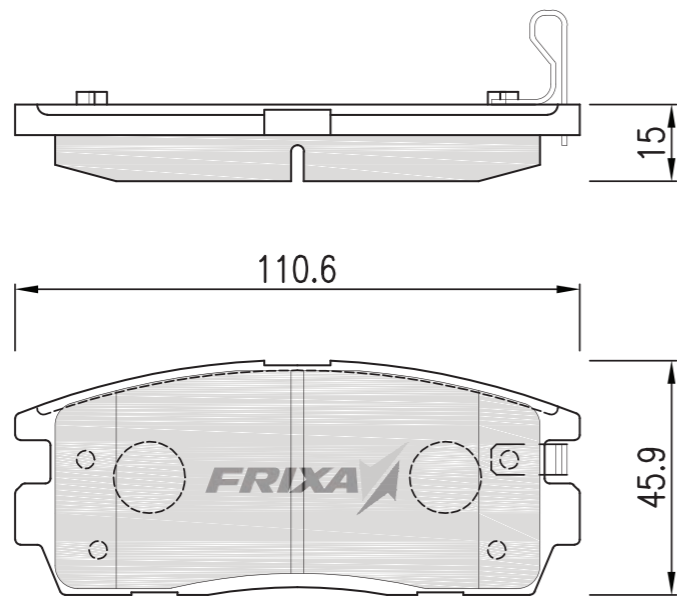

MAKER	SSANGYONG	PART NUMBER	66142-03021			FRIXA CODE
REPRESENTATIVE MODEL	ISTANA	INTERCHANGEABLE	ISTANA			FPY01
PO	SP	WVA	FMSI	HP	TRW	
FRONT	SP1083		D092	HP4003	GDB7614	

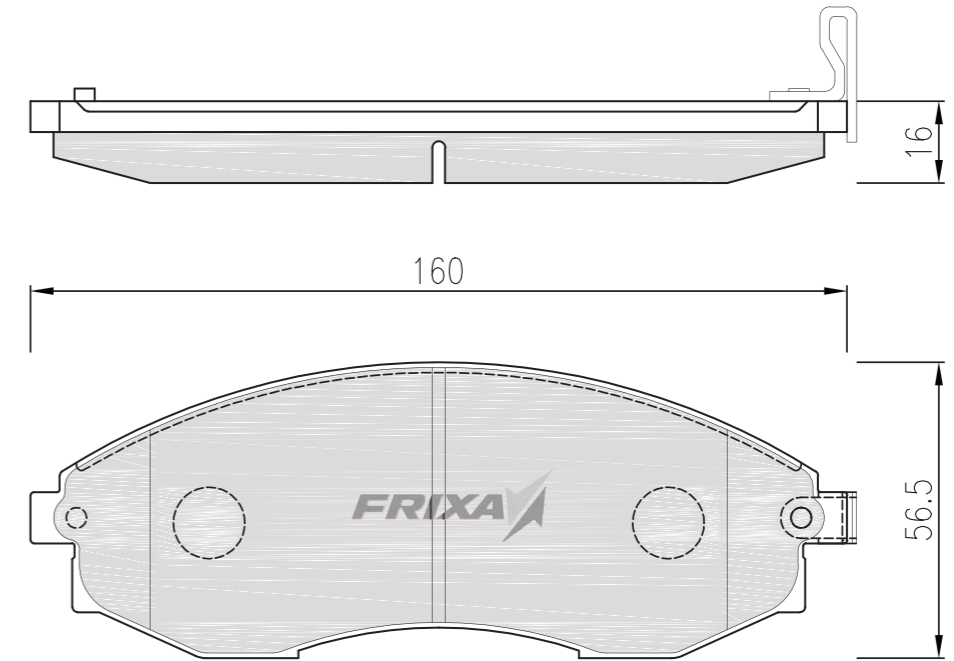

MAKER	SSANGYONG	PART NUMBER	48130-05000			FRIXA CODE
REPRESENTATIVE MODEL	MUSSO	INTERCHANGEABLE	MUSSO, MUSSO SPORTS KORANDO FAMILY, NEW KORANDO			FPY02
PO	SP	WVA	FMSI	HP	TRW	
FRONT	SP1065	21725	D449-7329	HP4001	GDB3101	

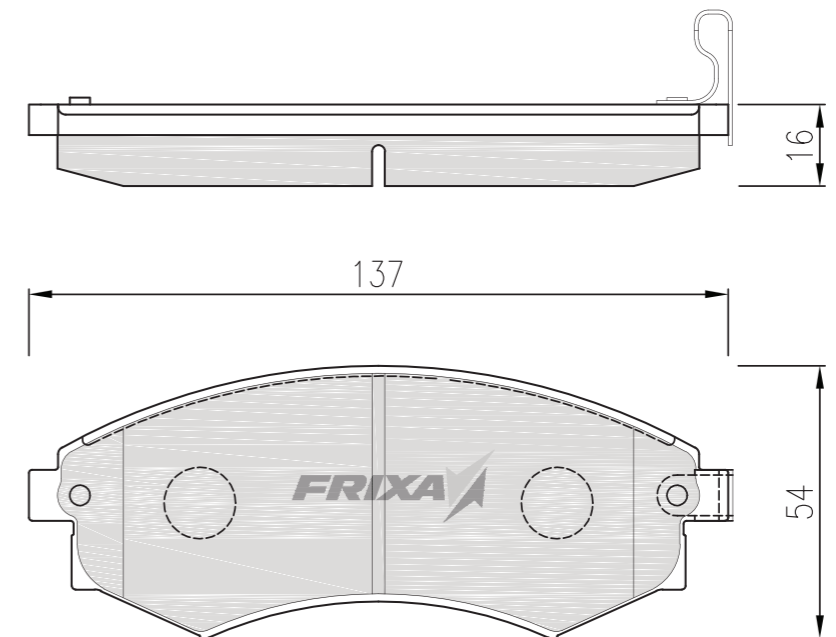

DISC BRAKE PAD

BRAKE SHOE ASSEMBLY

BRAKE LINING

DISC BRAKE PAD

BRAKE SHOE ASSEMBLY

BRAKE LINING

FRIXA CODE	MAKER	SSANGYONG		PART NUMBER 48130-08050		
FPY03	REPRESENTATIVE MODEL	REXTON	INTERCHANGEABLE		REXTON	
	PO	SP	WVA	FMSI	HP	TRW
	FRONT	SP1144	21725		HP4004	

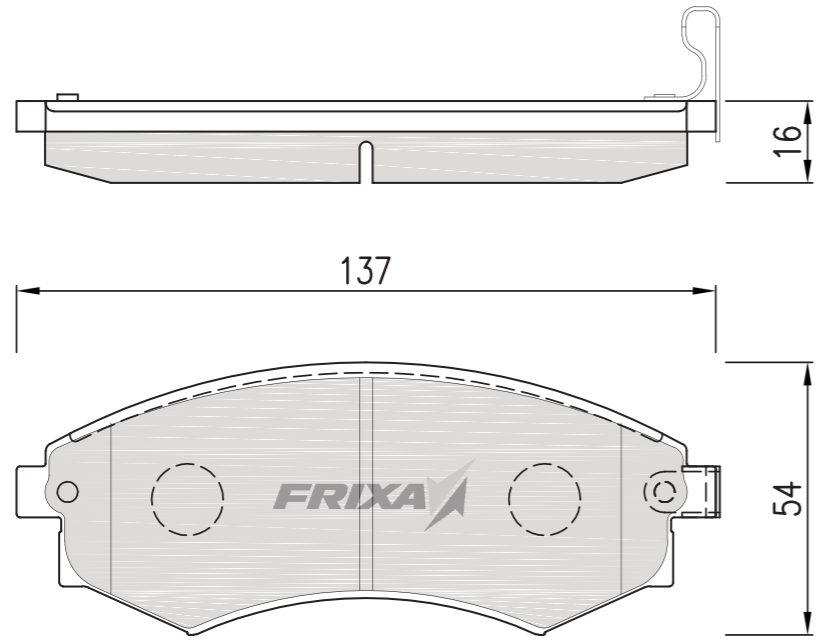

FRIXA CODE	MAKER	SSANGYONG		PART NUMBER 48150-110A2		
FPY04	REPRESENTATIVE MODEL	CHAIRMAN	INTERCHANGEABLE		CHAIRMAN, NEW CHAIRMAN	
	PO	SP	WVA	FMSI	HP	TRW
	FRONT	SP1088			HP4005	

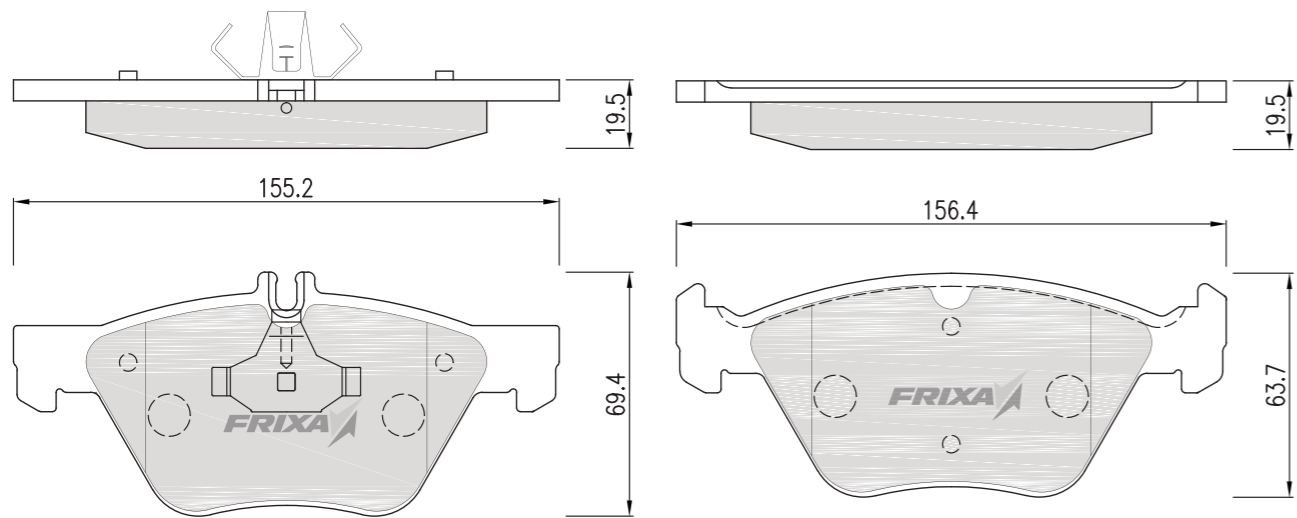

MAKER	SSANGYONG		PART NUMBER 48130-08250		FRIXA CODE
REPRESENTATIVE MODEL	KYRON	INTERCHANGEABLE		KYRON, NEW REXTON, ACTYON	
PO	SP	WVA	FMSI	HP	TRW
FRONT	SP1171	23569	D864-7739	HP4007	GDB3244

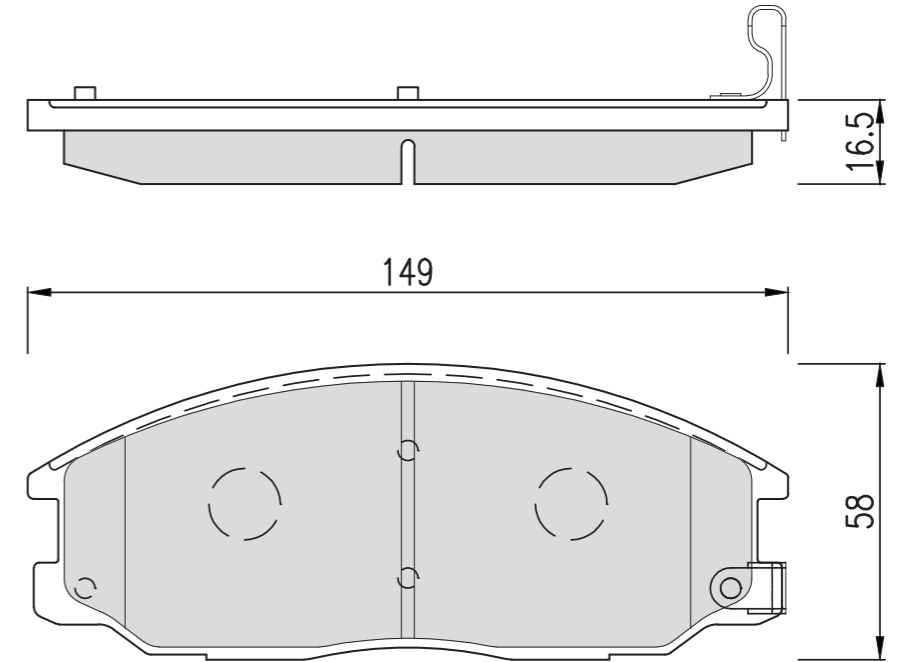

MAKER	SSANGYONG		PART NUMBER 48413-05100		FRIXA CODE
REPRESENTATIVE MODEL	REXTON	INTERCHANGEABLE		MUSSO, NEW KORANDO KYRON, ACTYON, REXTON	
PO	SP	WVA	FMSI	HP	TRW
REAR	SP1151	23673		HP4002	GDB3382

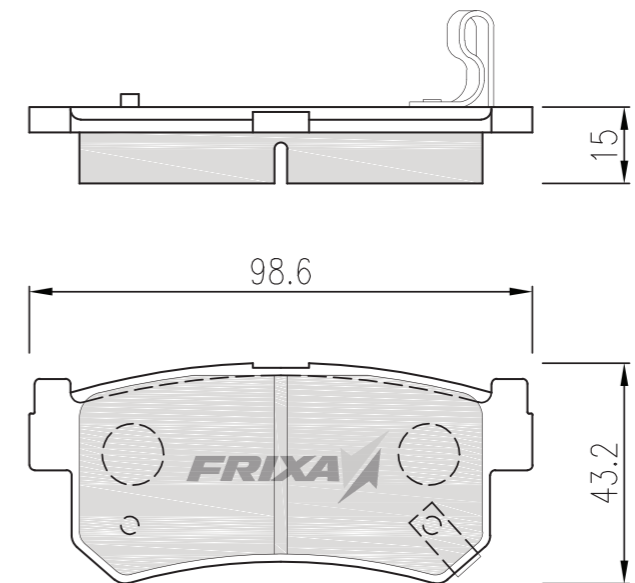

DISC BRAKE PAD

BRAKE SHOE ASSEMBLY

BRAKE LINING

DISC BRAKE PAD

BRAKE SHOE ASSEMBLY

BRAKE LINING

FRIXA CODE	MAKER	SSANGYONG	PART NUMBER	48450-110A0		
FPY04R	REPRESENTATIVE MODEL	CHARIMAN	INTERCHANGEABLE	CHARIMAN		
	PO	SP	WVA	FMSI	HP	TRW
	REAR	SP1089				

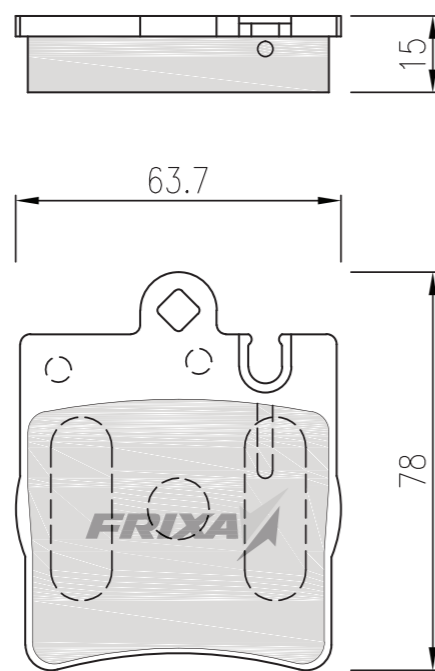

FRIXA CODE	MAKER	SSANGYONG	PART NUMBER	48413-091A0		
FPY05R	REPRESENTATIVE MODEL	RODIUS	INTERCHANGEABLE	RODIUS, KYRON IRS ACTYON IRS		
	PO	SP	WVA	FMSI	HP	TRW
	REAR	SP1173	23931	D954-7853		GDB3413

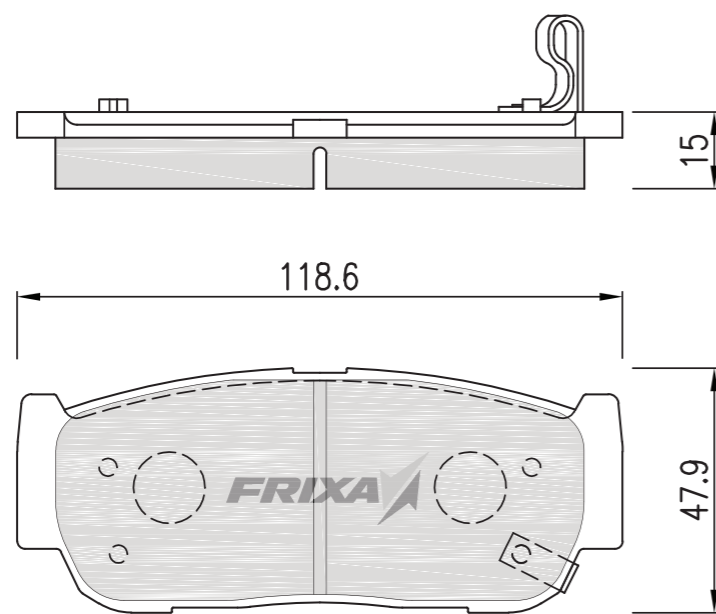

MAKER	SAMSUNG	PART NUMBER	41060-2Y090			FRIXA CODE
REPRESENTATIVE MODEL	SM-5	INTERCHANGEABLE	518 / 520 / 525			FPS01
PO	SP	WVA	FMSI	HP	TRW	
FRONT	SP1107-F	21561	D430-7832	HP3001	GDB1003	

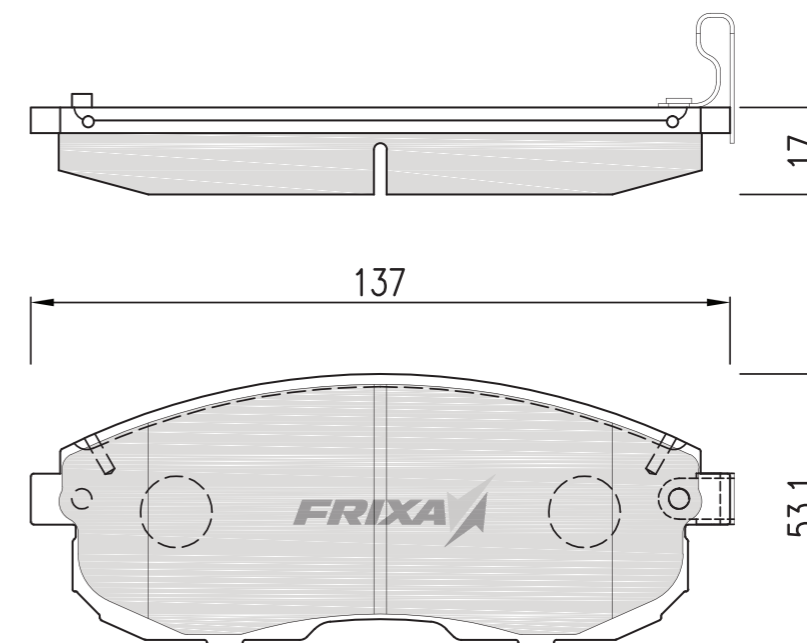

MAKER	SAMSUNG	PART NUMBER	41060-4M490			FRIXA CODE
REPRESENTATIVE MODEL	SM-3	INTERCHANGEABLE	SM-3			FPS02
PO	SP	WVA	FMSI	HP	TRW	
FRONT	SP1156	24647	D1193-8311	HP3004	GDB7043	

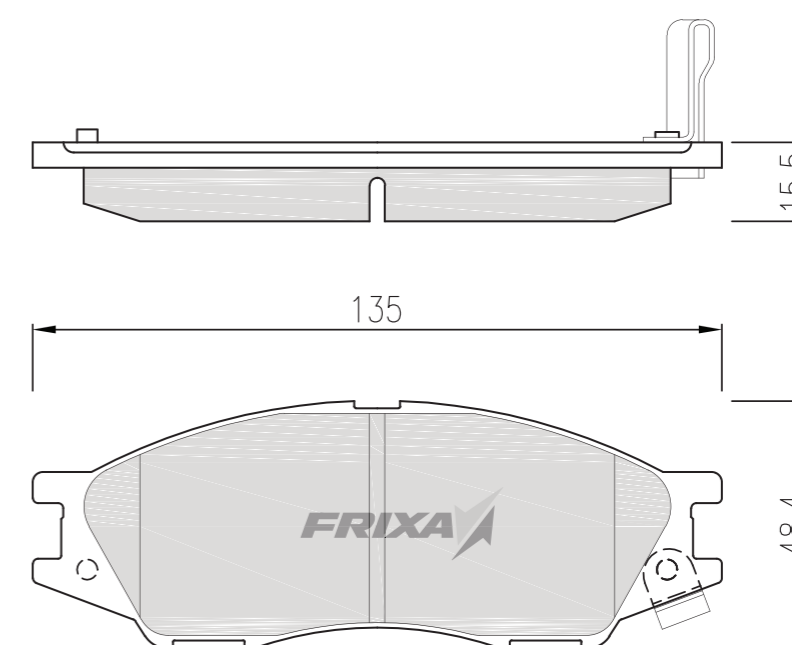

DISC BRAKE PAD

BRAKE SHOE ASSEMBLY

BRAKE LINING

DISC BRAKE PAD

BRAKE SHOE ASSEMBLY

BRAKE LINING

FRIXA CODE	MAKER	SAMSUNG		PART NUMBER		48111-52100K0
FPS03	REPRESENTATIVE MODEL	SM-7	INTERCHANGEABLE		NEWSM-5, SM-7	
	PO	SP	WVA	FMSI	HP	TRW
	FRONT	SP1183			HP3005	

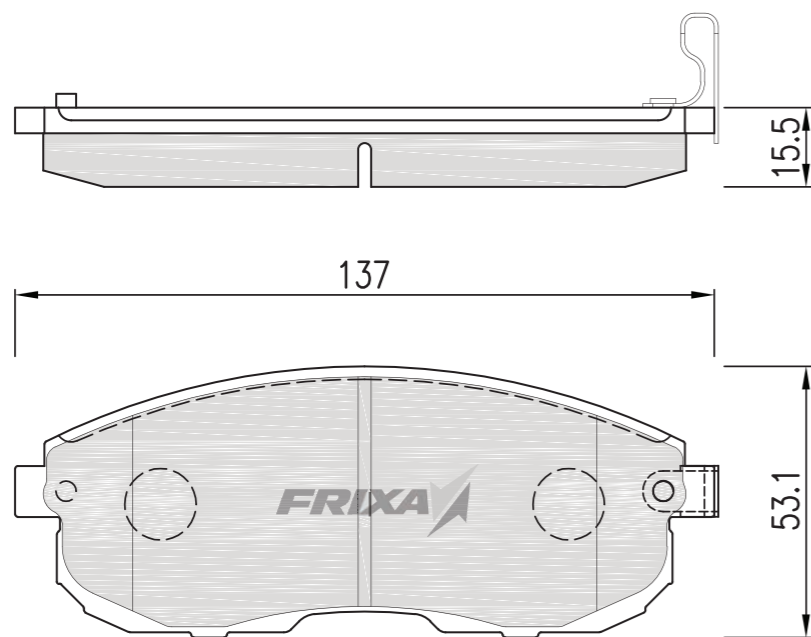

FRIXA CODE	MAKER	SAMSUNG		PART NUMBER		41060-0013R
FPS04	REPRESENTATIVE MODEL	QM-5	INTERCHANGEABLE		QM-5	
	PO	SP	WVA	FMSI	HP	TRW
	FRONT	SP1249	23698	D888-7766		

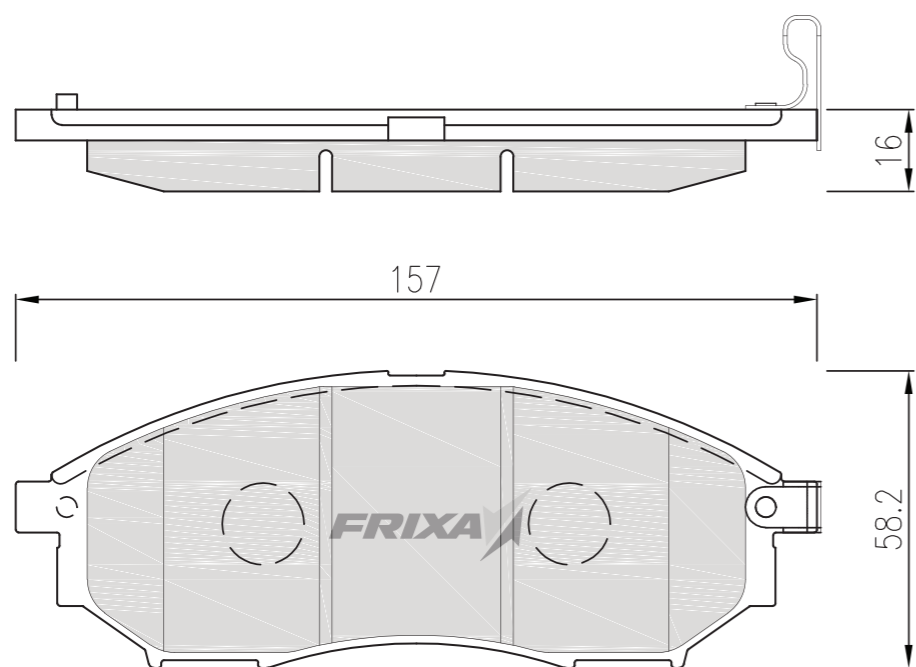

MAKER	SAMSUNG		PART NUMBER		41 06 083 64R	FRIXA CODE
REPRESENTATIVE MODEL	NEW SM-3	INTERCHANGEABLE		NEW SM-3		FPS05
PO	SP	WVA	FMSI	HP	TRW	
FRONT						

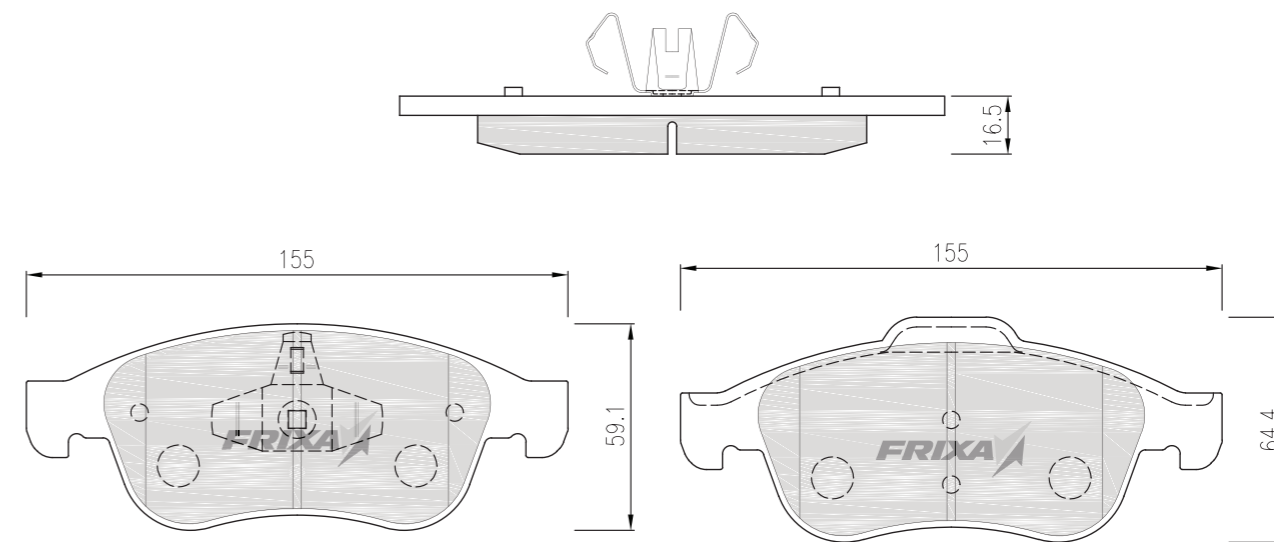

MAKER	SAMSUNG		PART NUMBER		48311-51110K0	FRIXA CODE
REPRESENTATIVE MODEL	SM-5R	INTERCHANGEABLE		518 / 520 / 525		FPS01R
PO	SP	WVA	FMSI	HP	TRW	
REAR	SP1107-R	21713	D540-7533	HP3002	GDB1172	

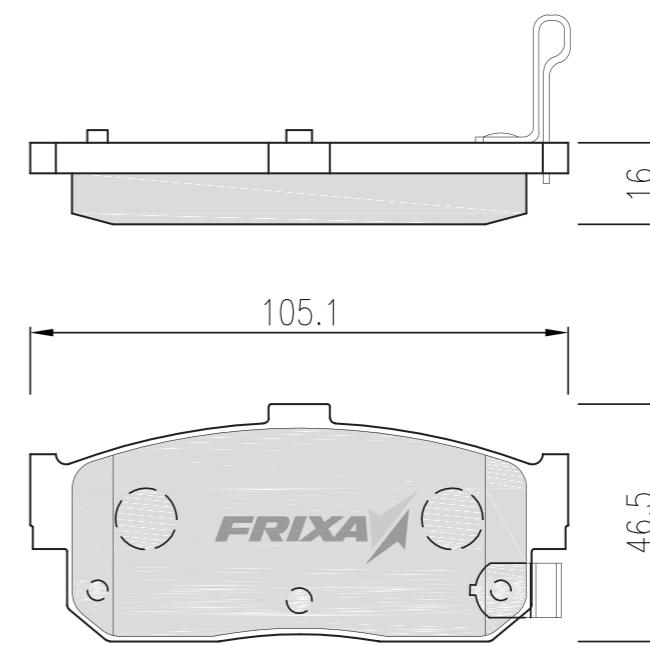

DISC BRAKE PAD

BRAKE SHOE ASSEMBLY

BRAKE LINING

DISC BRAKE PAD

BRAKE SHOE ASSEMBLY

BRAKE LINING

FRIXA CODE	MAKER	SAMSUNG		PART NUMBER	44060-4U092	
FPS01NR	REPRESENTATIVE MODEL	SM-5R(NEW)	INTERCHANGEABLE	SM-5 02MY		
	PO	SP	WVA	FMSI	HP	TRW
	REAR	SP1163	24039	D900-7777	HP3003	

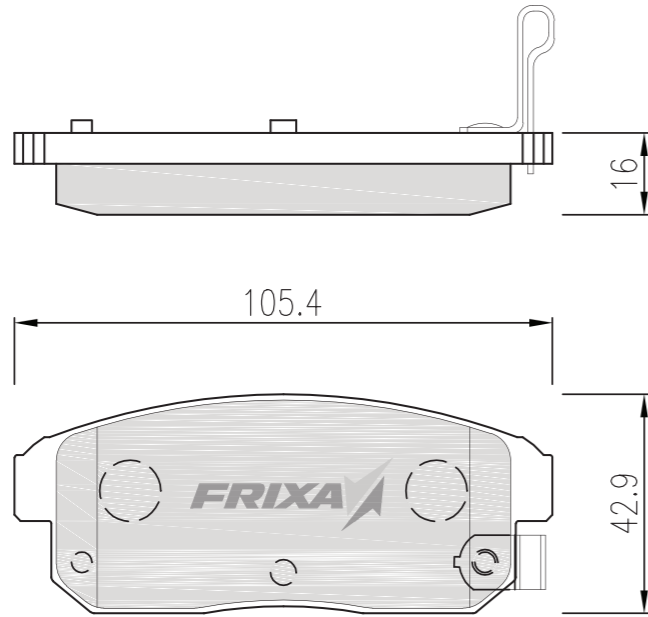

FRIXA CODE	MAKER	SAMSUNG		PART NUMBER	44060-8H385	
FPS03R	REPRESENTATIVE MODEL	SM-7R	INTERCHANGEABLE	NEW SM-5, SM-7		
	PO	SP	WVA	FMSI	HP	TRW
	REAR	SP1184	23814	D1393-8501		GDB3294

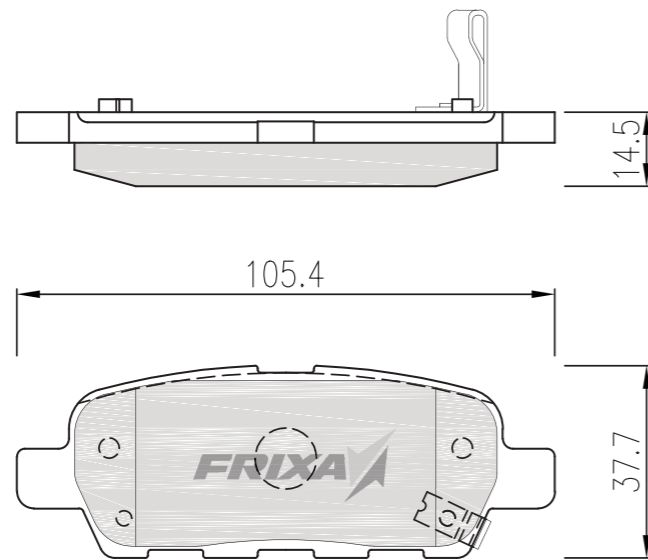

MAKER	SAMSUNG		PART NUMBER	44 06 020 70R		FRIXA CODE
REPRESENTATIVE MODEL	NEW SM-3	INTERCHANGEABLE	NEW SM-3			FPS05R
PO	SP	WVA	FMSI	HP	TRW	
REAR	SP1173					

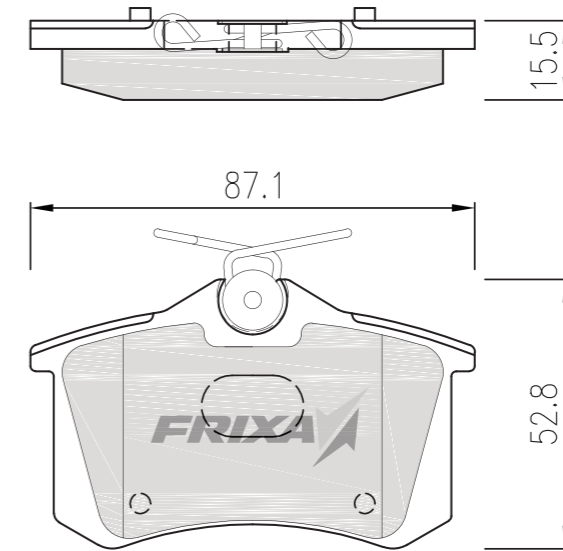

MAKER	TOYOTA		PART NUMBER	04465-22040		FRIXA CODE
REPRESENTATIVE MODEL	CROWN	INTERCHANGEABLE	COMFORT GXS10, YXS10, YXS11 97~ SXS13Y, YXS11Y 01~			FPE011
PO	SP	WVA	FMSI	HP	TRW	
FRONT			7320-D433		GDB1026	

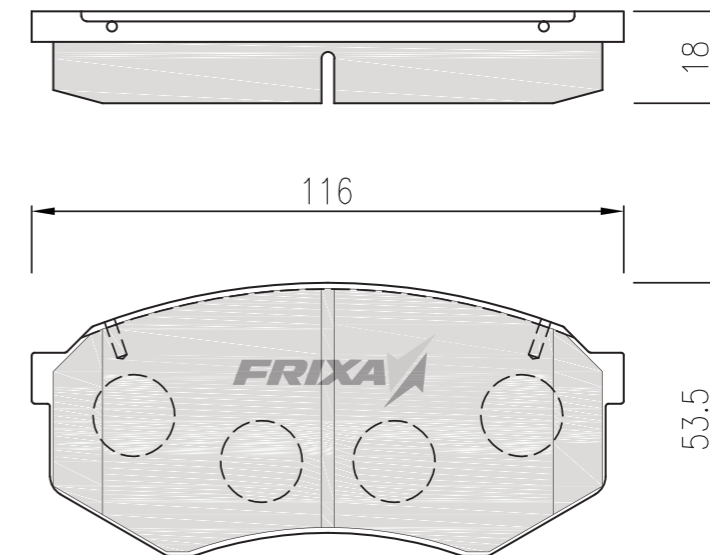

DISC BRAKE PAD

BRAKE SHOE ASSEMBLY

BRAKE LINING

DISC BRAKE PAD

BRAKE SHOE ASSEMBLY

BRAKE LINING

FRIXA CODE	MAKER	NISSAN		PART NUMBER		41000-10G08
FPE012	REPRESENTATIVE MODEL	CREW, CEDRIC	INTERCHANGEABLE		ALL MODEL 94~ GLORIA Y31, Y31 ABSTYPE 91~	
	PO	SP	WVA	FMSI	HP	TRW
	FRONT			7228-D333		GDB1017

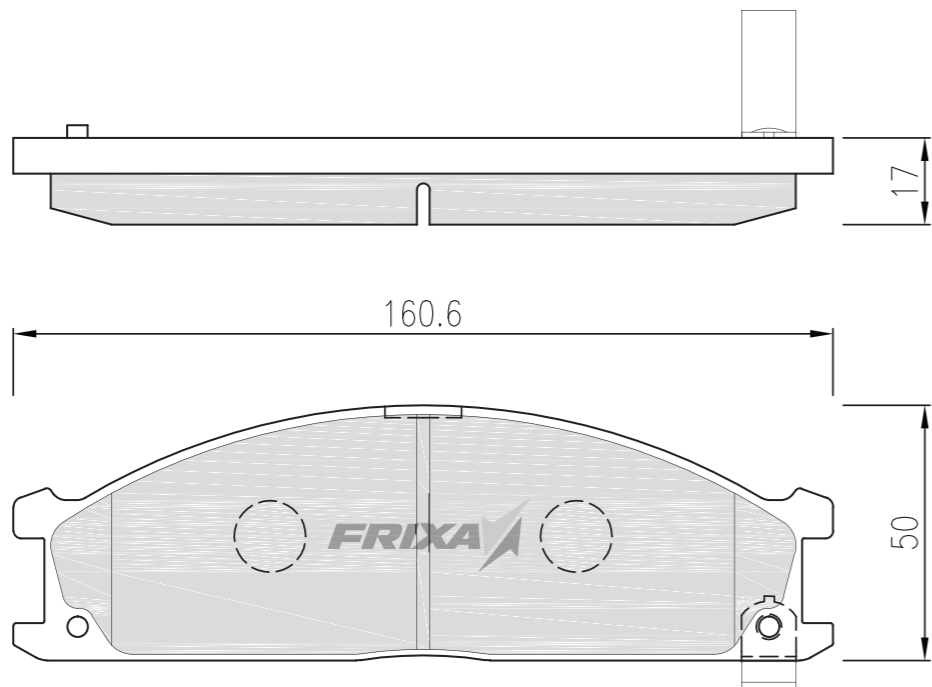

FRIXA CODE	MAKER	TOYOTA		PART NUMBER		04465-30300
FPE013	REPRESENTATIVE MODEL	MARK2BULT ESTATE CROWN	INTERCHANGEABLE		GX110W, JZX110W 02~ JZS171W, JZS175W 99~ FS171, JZS175 99~	
	PO	SP	WVA	FMSI	HP	TRW
	FRONT					

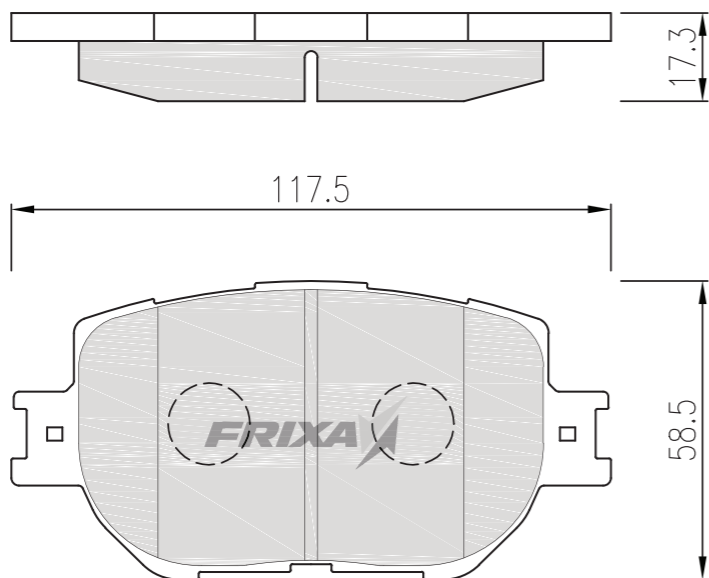

MAKER	TOYOTA		PART NUMBER		04466-22180	FRIXA CODE
REPRESENTATIVE MODEL	CROWN PROGRESS ALTEZZA	INTERCHANGEABLE		R JZS171, 175, 177 99~ R JCG10, JCG11 98~ R SXE10, GXE10 98~		FPE014
PO	SP	WVA	FMSI	HP	TRW	
REAR			7638-D771		GDB3233	

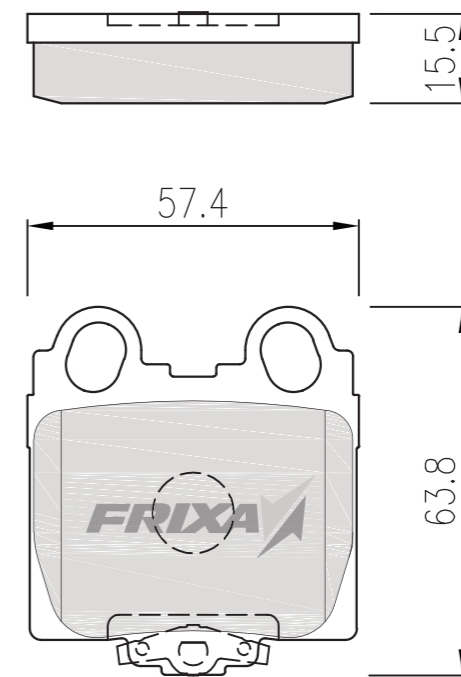

MAKER	DAIHATSU		PART NUMBER		04491-87514	FRIXA CODE
REPRESENTATIVE MODEL	HI JET	INTERCHANGEABLE		S200V, S210V 99~ S220V, S230V 99~		FPE015
PO	SP	WVA	FMSI	HP	TRW	
FRONT						

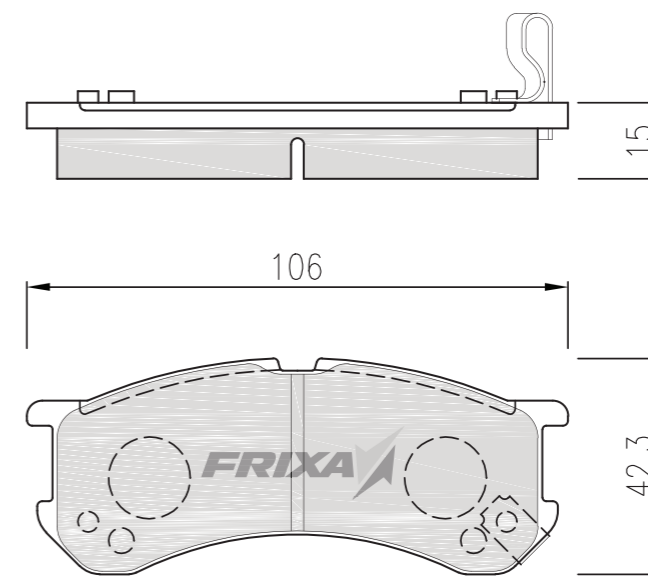

DISC BRAKE PAD

BRAKE SHOE ASSEMBLY

BRAKE LINING

DISC BRAKE PAD

BRAKE SHOE ASSEMBLY

BRAKE LINING

FRIXA CODE	MAKER	ISUZU	PART NUMBER		8-97203209		FRIXA CODE
FPE016	REPRESENTATIVE MODEL	ELF	INTERCHANGEABLE		KK-NPR72, NPR72L, NPR72P 99~ KK-NPR75 99~ KK-NPR75LR, NPR75PR 02~		FPE06
	PO	SP	WVA	FMSI	HP	TRW	
	FRONT						

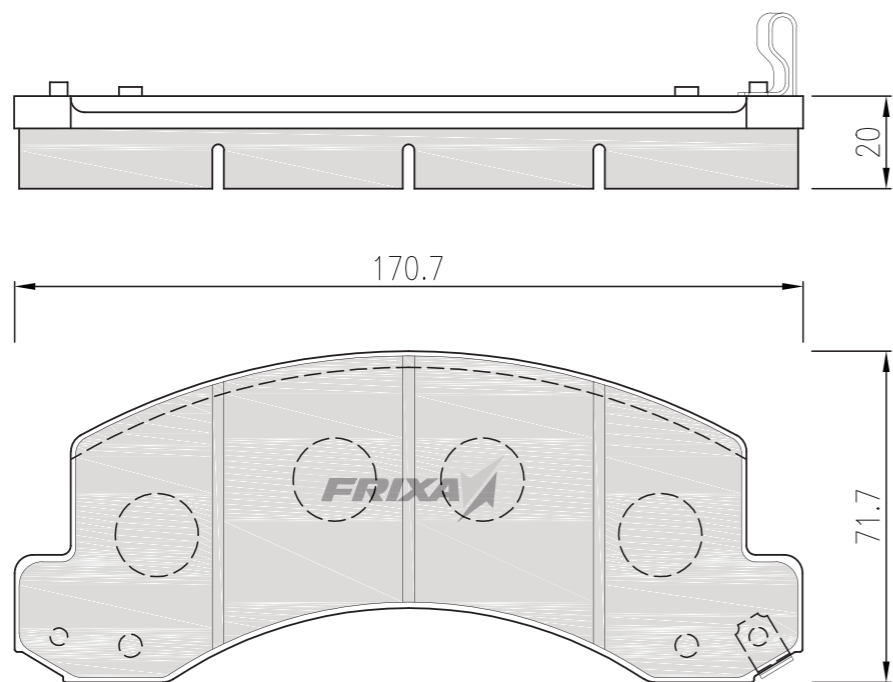

FRIXA CODE	MAKER	mitsubishi	PART NUMBER		MK449107		FRIXA CODE
FPE017	REPRESENTATIVE MODEL	CANTER	INTERCHANGEABLE		FE70C, 71C, 72C, 73C, 82C, 83C 02~ FE82D 02~ FE70E, 71E, 72E, 78E 02~		FPE018
	PO	SP	WVA	FMSI	HP	TRW	
	FRONT						

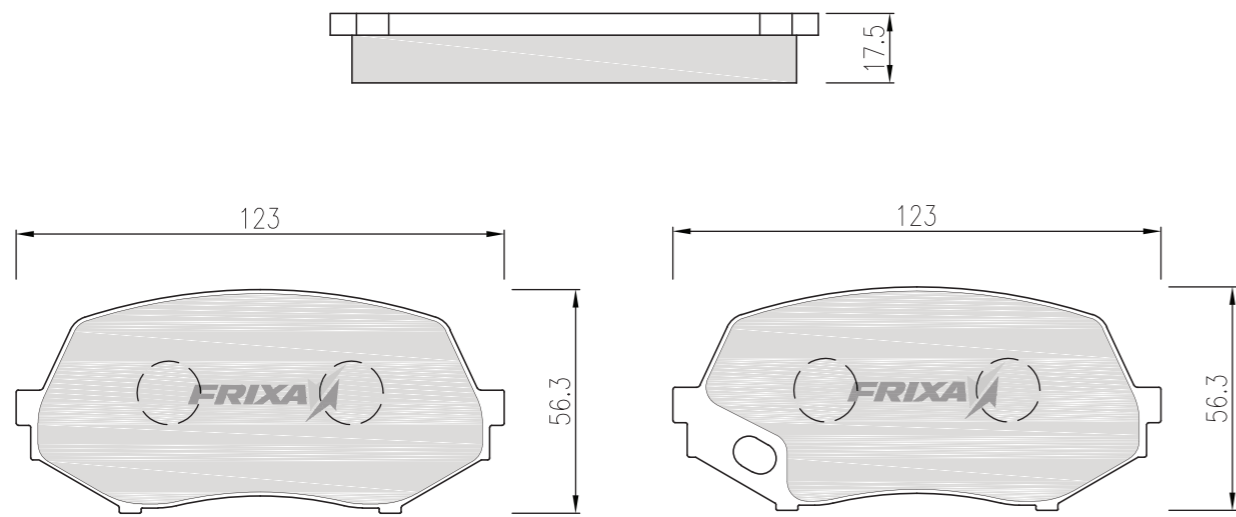

MAKER	NISSAN	PART NUMBER		41060-0V090		FRIXA CODE
REPRESENTATIVE MODEL	PRIMERA STAGEA TEANA	INTERCHANGEABLE		HP12, TP12 01~ M35, NM35, HM35 01~ J31, TNJ31, PJ31 03~		FPE06
PO	SP	WVA	FMSI	HP	TRW	
FRONT		24280	7407-D526		GDB3390	

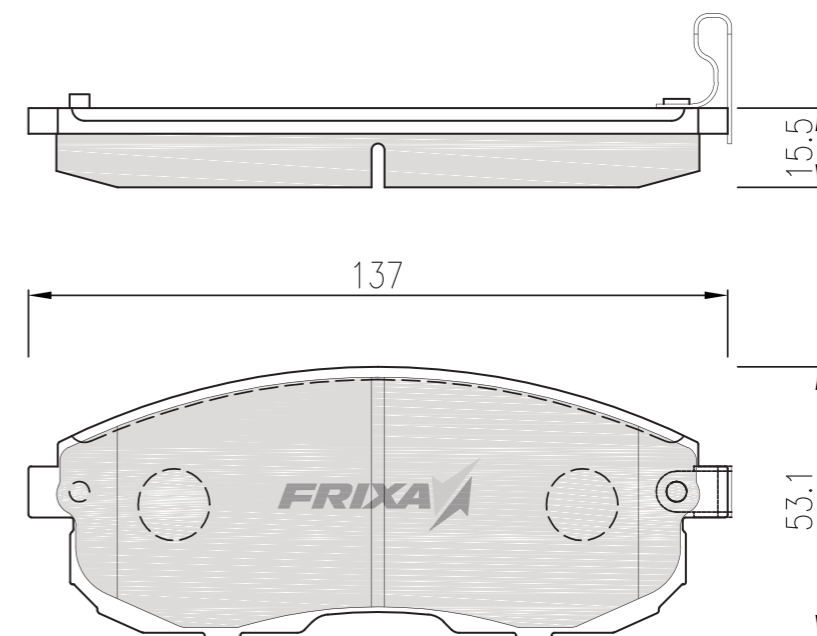

MAKER	TOYOTA	PART NUMBER		04465-26420		FRIXA CODE
REPRESENTATIVE MODEL	REGIUS ACE HI ACE	INTERCHANGEABLE		TRH200V, KDH205V 04.08~ TRH200V, KDH200V 04.08~, TRH229W 05.01~		FPE018
PO	SP	WVA	FMSI	HP	TRW	
FRONT						

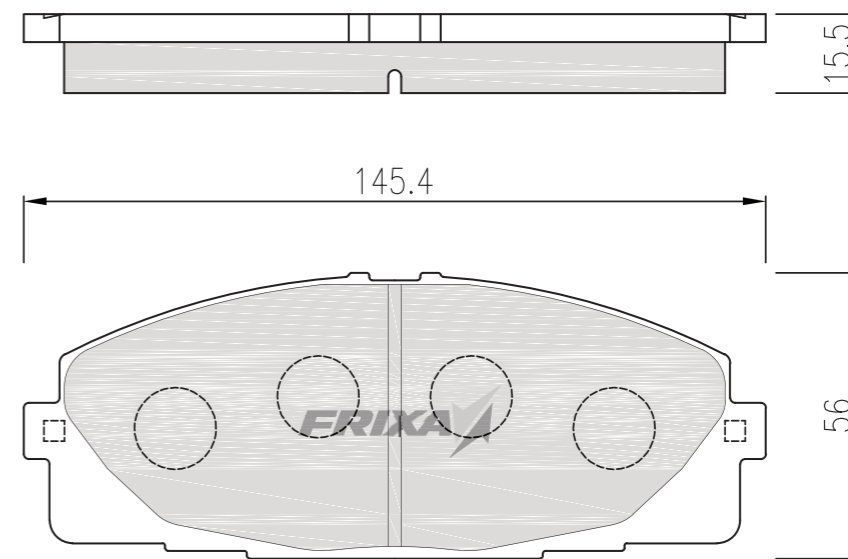

DISC BRAKE PAD

BRAKE SHOE ASSEMBLY

BRAKE LINING

DISC BRAKE PAD

BRAKE SHOE ASSEMBLY

BRAKE LINING

FRIXA CODE	MAKER	TOYOTA	PART NUMBER		04465-30340	
FPE019	REPRESENTATIVE MODEL	CAMRY CROWN MARK X	INTERCHANGEABLE		VISTA ACV30, ACV35 01.09~06.01 ZESTA UZS16, UZS187 04.01~ GRX120 04.11~	
	PO	SP	WVA	FMSI	HP	TRW
	FRONT		23806	7787-D1052		GDB3314

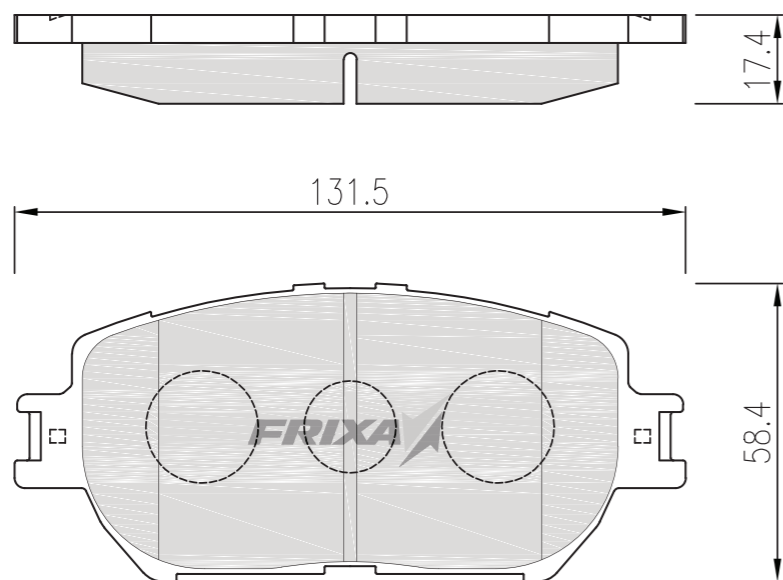

FRIXA CODE	MAKER	TOYOTA	PART NUMBER		04465-30280	
FPE020	REPRESENTATIVE MODEL	CRWON MARK X	INTERCHANGEABLE		CROWN GRS180, GRS182 03.12~ GRX120 04.11~	
	PO	SP	WVA	FMSI	HP	TRW
	FRONT					

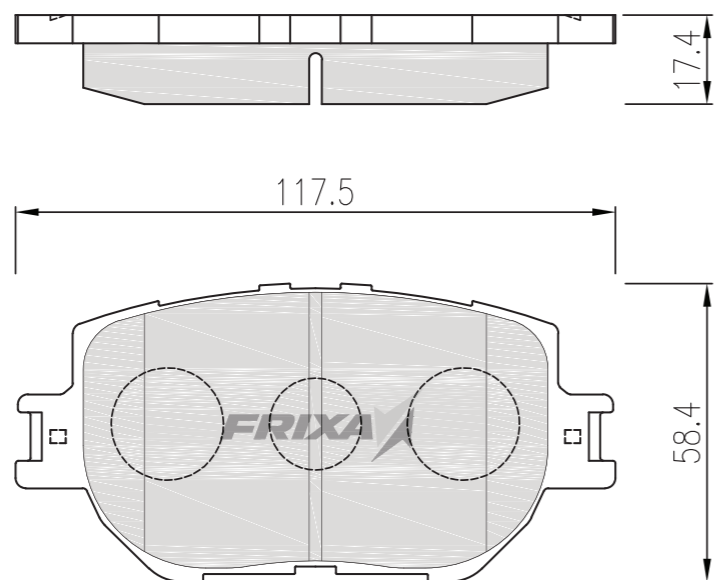

MAKER	HONDA	PART NUMBER		45022-S0A-J20		FRIXA CODE
REPRESENTATIVE MODEL	ODYSSEY	INTERCHANGEABLE		RB1, RB2 03.10~		FPE021
PO	SP	WVA	FMSI	HP	TRW	
FRONT			D787		GDB3240	

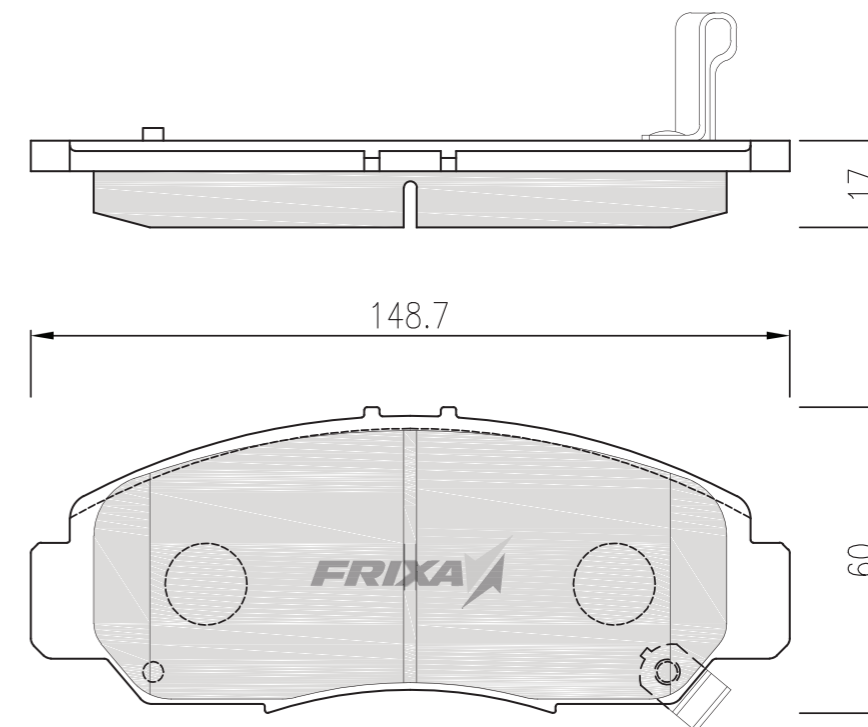

MAKER	TOYOTA	PART NUMBER		04465-48100		FRIXA CODE
REPRESENTATIVE MODEL	HARRIER	INTERCHANGEABLE		ACU30W, ACU35W 03.2~ MCU30W, MCU36W 03.2~ MHU38W 05.3~		FPE022
PO	SP	WVA	FMSI	HP	TRW	
FRONT			7906-D1005		GDB3338	

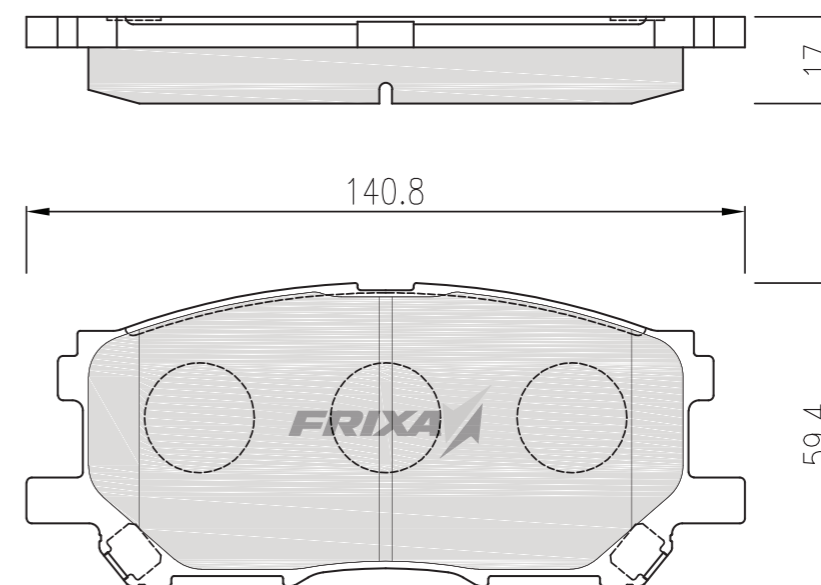

DISC BRAKE PAD

BRAKE SHOE ASSEMBLY

BRAKE LINING

DISC BRAKE PAD

BRAKE SHOE ASSEMBLY

BRAKE LINING

FRIXA CODE	MAKER	PEUGEOT	PART NUMBER		4250.95	
FPE023	REPRESENTATIVE MODEL	405	INTERCHANGEABLE			
	PO	SP	WVA	FMSI	HP	TRW
	FRONT		21209			GDB793

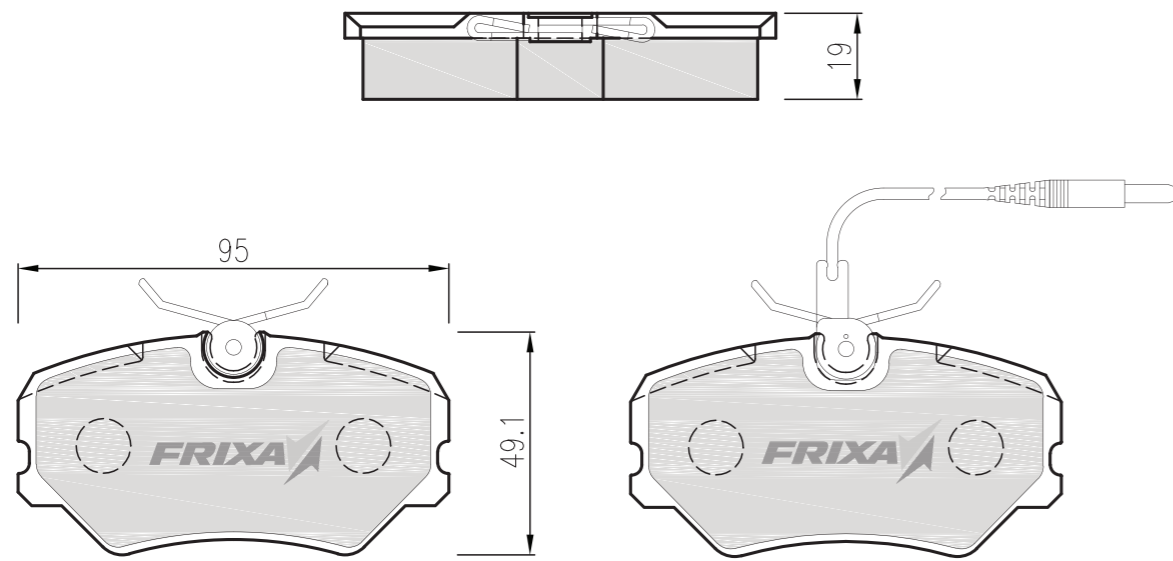

FRIXA CODE	MAKER	PEUGEOT	PART NUMBER		425212	
FPE024	REPRESENTATIVE MODEL	206	INTERCHANGEABLE			
	PO	SP	WVA	FMSI	HP	TRW
	FRONT		23597	8254-D1143		GDB1361

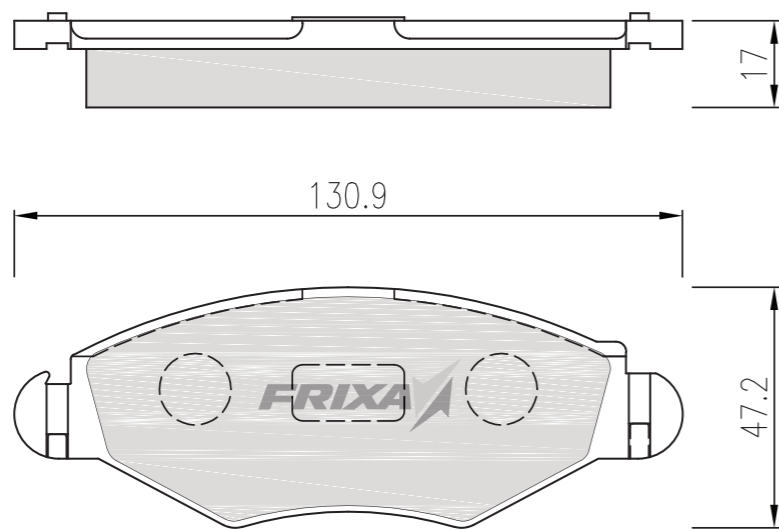

MAKER	NISSAN	PART NUMBER		41060-HA025		FRIXA CODE
REPRESENTATIVE MODEL	VANETTE	INTERCHANGEABLE				FPE025
PO	SP	WVA	FMSI	HP	TRW	
FRONT			7791-D867		GDB3246	

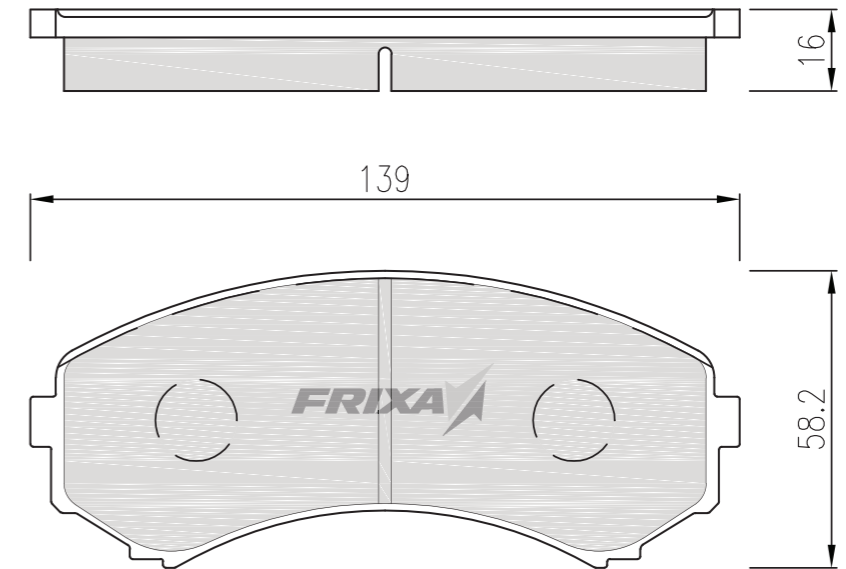

MAKER	DAIHATSU	PART NUMBER		04491-87506-000		FRIXA CODE
REPRESENTATIVE MODEL	HI JET	INTERCHANGEABLE				FPE026
PO	SP	WVA	FMSI	HP	TRW	
FRONT						

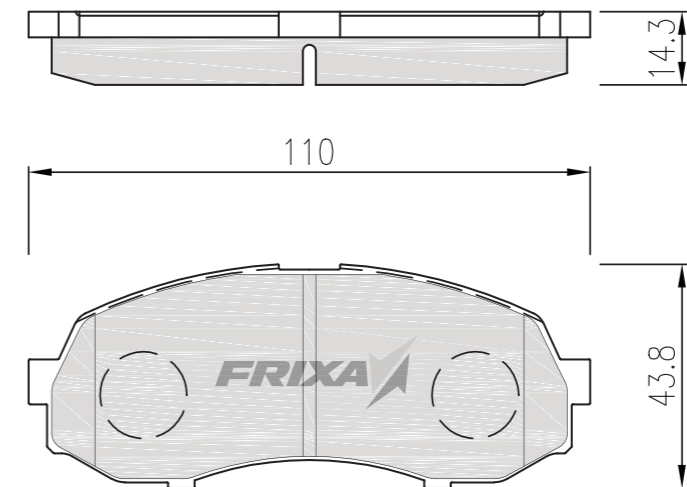

DISC BRAKE PAD

BRAKE SHOE ASSEMBLY

BRAKE LINING

DISC BRAKE PAD

BRAKE SHOE ASSEMBLY

BRAKE LINING

FRIXA CODE	MAKER	SUBARU		PART NUMBER	26296-TC001	
FPE027	REPRESENTATIVE MODEL	SAMBAR	INTERCHANGEABLE	TV1, TV2, TT1, TT2 99.1~04.08		
	PO	SP	WVA	FMSI	HP	TRW
	FRONT					GDB1420

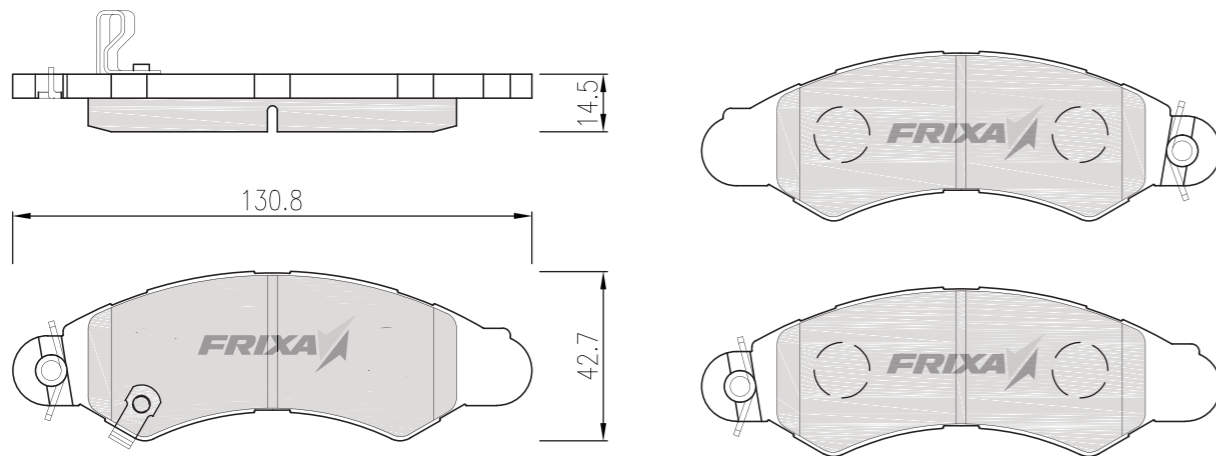

FRIXA CODE	MAKER	HONDA		PART NUMBER	45022-S2K-000	
FPE028	REPRESENTATIVE MODEL	LIFE ACTY BAMOS	INTERCHANGEABLE	JB1, JB2 98.10~ JB5, JB6 03.10~ HH25, HH6 99.6~ HM3, HM4, HJ1, HJ2 03.4~		
	PO	SP	WVA	FMSI	HP	TRW
	FRONT					

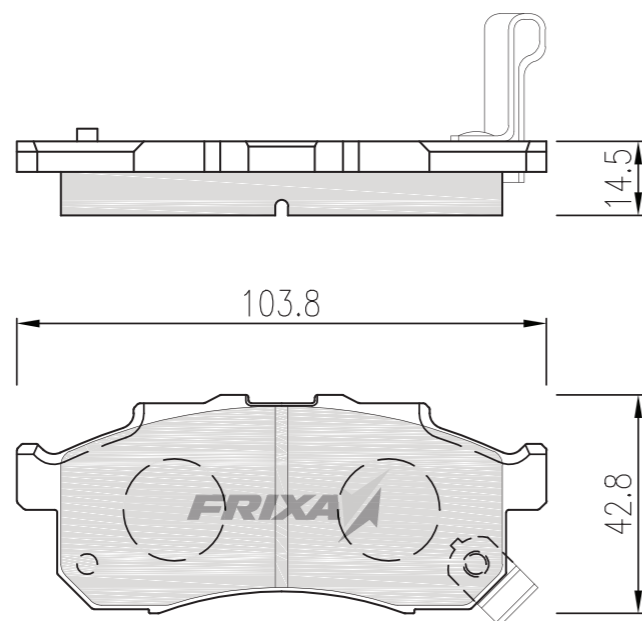

MAKER	SUZUKI		PART NUMBER	26296-KG000		FRIXA CODE
REPRESENTATIVE MODEL	ALTO K WAGAN R	INTERCHANGEABLE	ALTO HA23V 00.12~ HA24S 04.9~ HN12S, HN22S 01.4~ MC12S, MC22S 00.12~ MH21S 03.9~			FPE029
PO	SP	WVA	FMSI	HP	TRW	
FRONT		23507	D1225-8344			

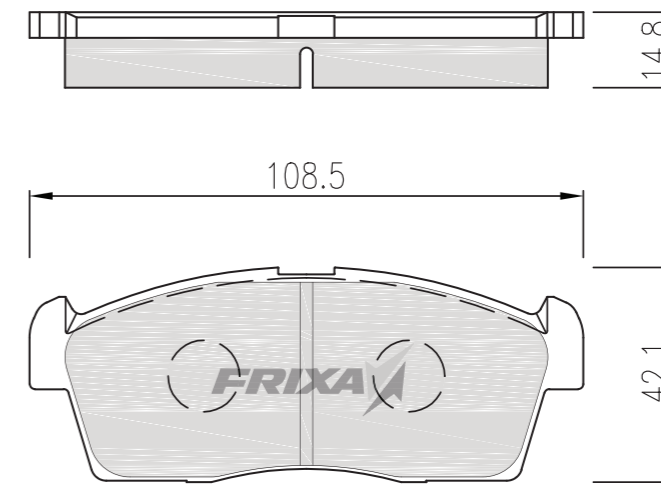

MAKER	HONDA		PART NUMBER	06450-S0A-J00		FRIXA CODE
REPRESENTATIVE MODEL	ACCORD ODYSSEY STEP WAGON	INTERCHANGEABLE	CF4, CF5 97.9~02.9 RA3, RA4 97.8~99.12 RF5, RF6, RF7, RF8 03.6~05.5			FPE030
PO	SP	WVA	FMSI	HP	TRW	
FRONT		21651	D503-7382		GDB1062	

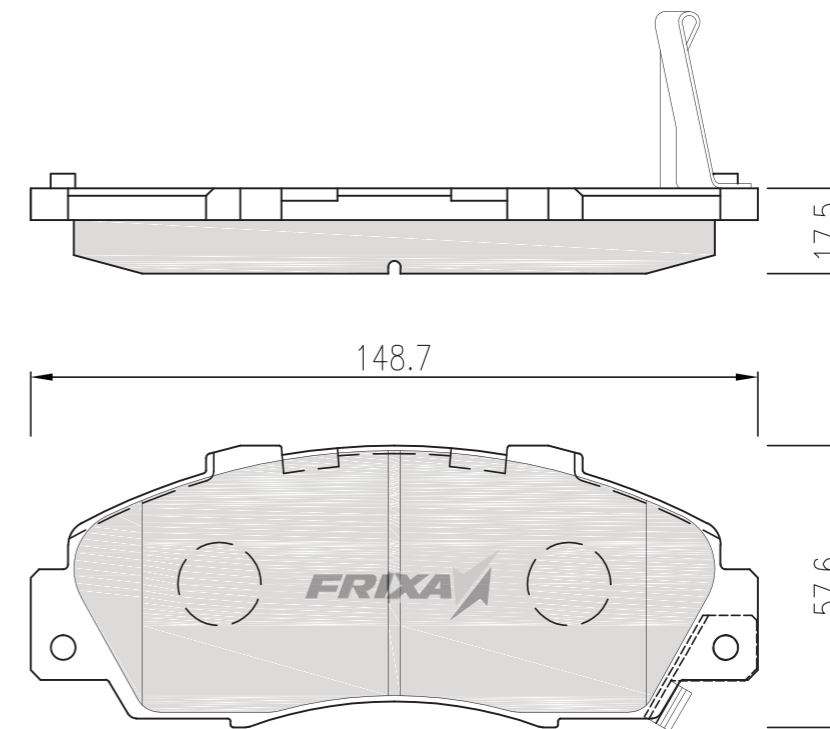

DISC BRAKE PAD

BRAKE SHOE ASSEMBLY

BRAKE LINING

DISC BRAKE PAD

BRAKE SHOE ASSEMBLY

BRAKE LINING

FRIXA CODE	MAKER	ISUZU	PART NUMBER	8-97078409		
FPE031	REPRESENTATIVE MODEL	ELF	INTERCHANGEABLE	NKR69, NHS69, WKR69 99.5~02.5 NKR69EA, NHS69EA, NKR81EA, NKR81LAR 02.6~ VKR66K 96.11~02.5		
	PO	SP	WVA	FMSI	HP	TRW
	FRONT					

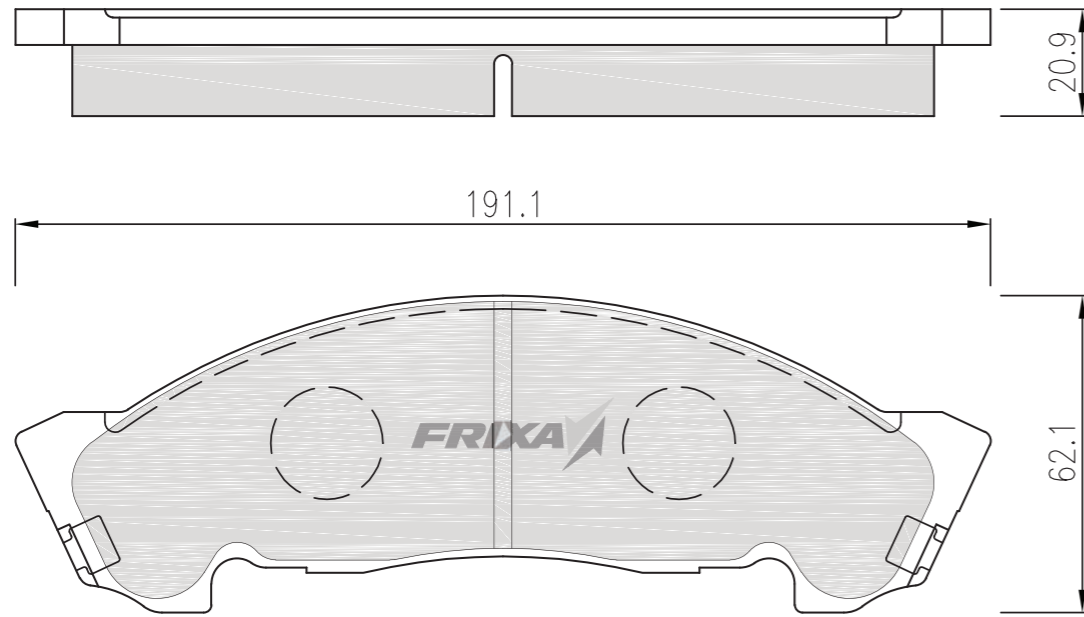

FRIXA CODE	MAKER	HONDA	PART NUMBER	06430-S0A-J00		
FPE035	REPRESENTATIVE MODEL	ODYSSEY STEP WAGON	INTERCHANGEABLE	RA6, RA7 99.12~03.10, RA8, RA9 00.1~03.10 RF1, RF2 96.4~01.4, FR3, RF4 01.4~, RF5, RF6, RF7, RF8 03.6		
	PO	SP	WVA	FMSI	HP	TRW
	FRONT		21719	D1086-7418		GDB1063

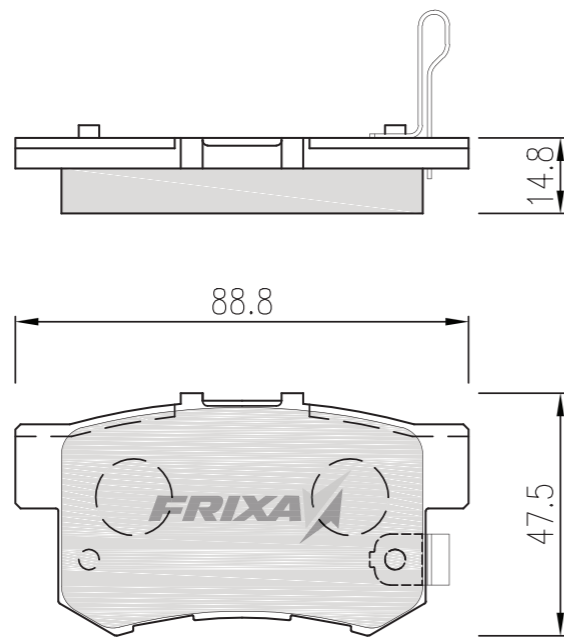

MAKER	SUZUKI	PART NUMBER	55210-60FA1			FRIXA CODE
REPRESENTATIVE MODEL	WAGON ALTO CERVO MODE	INTERCHANGEABLE	CT21S, CV21S 95.1~98.10, CT51S, CV51S 97.4~98.10 HA11S, HB11S, HC11V, HD11V 94.11~98.9 CN22S, CP22S 95.10~98.6			FPE036
PO	SP	WVA	FMSI	HP	TRW	
FRONT						

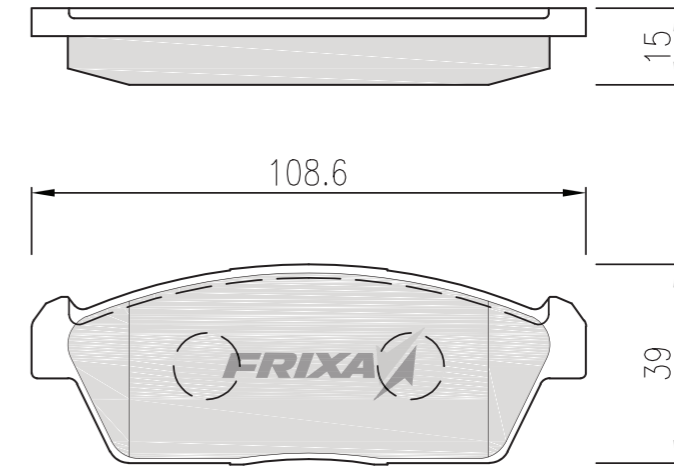

MAKER	TOYOTA	PART NUMBER	04465-52190			FRIXA CODE
REPRESENTATIVE MODEL	VITS VERTA LACTIS	INTERCHANGEABLE	NCP91 05. 02~ SCP92 05. 11~ SCP100, NCP100, NCP105 05. 10~			FPE037
PO	SP	WVA	FMSI	HP	TRW	
FRONT					GDB3460	

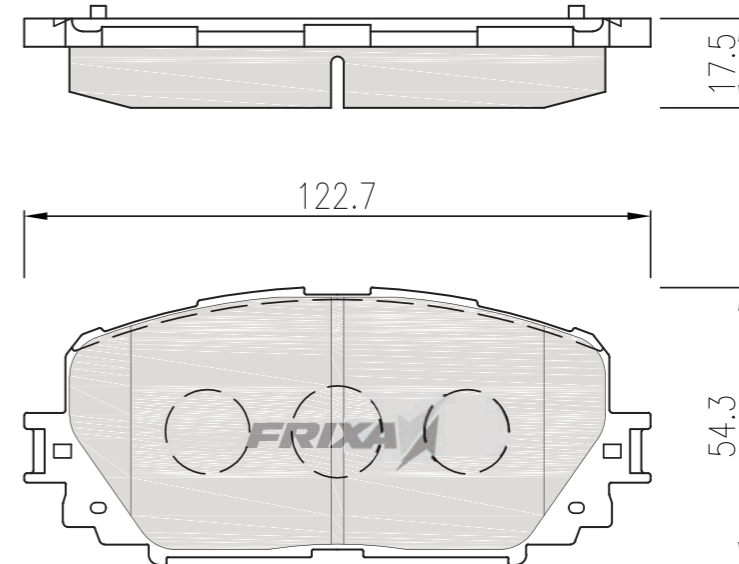

DISC BRAKE PAD

BRAKE SHOE ASSEMBLY

BRAKE LINING

DISC BRAKE PAD

BRAKE SHOE ASSEMBLY

BRAKE LINING

FRIXA CODE	MAKER	NISSAN		PART NUMBER	41060-EA025	
FPE038	REPRESENTATIVE MODEL	CERENA	INTERCHANGEABLE	C25, NC25 05. 05~		
	PO	SP	WVA	FMSI	HP	TRW
	FRONT					GDB3404

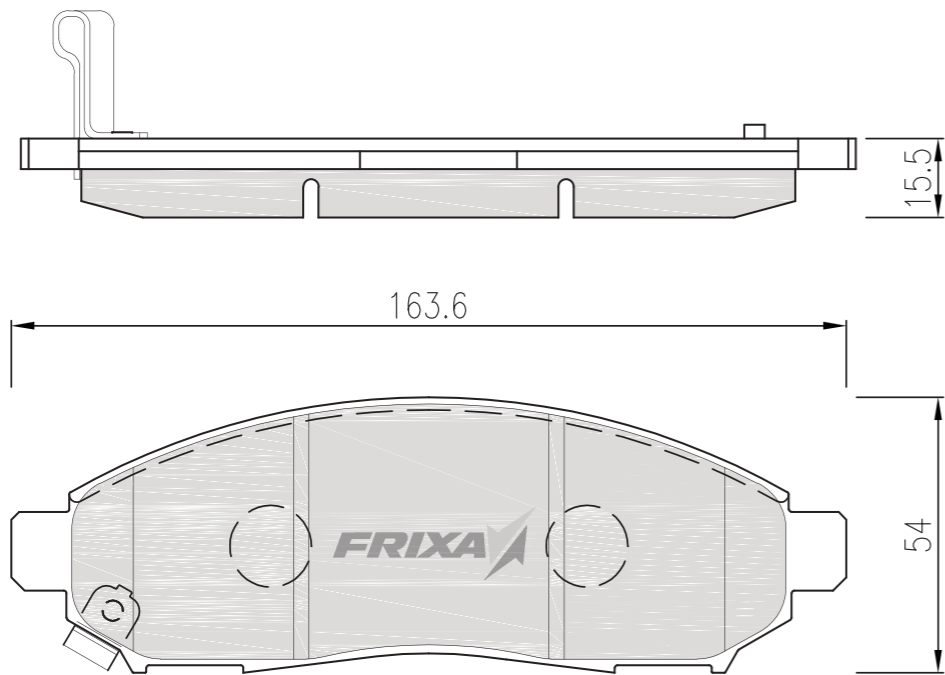

FRIXA CODE	MAKER	TOYOTA		PART NUMBER	04466-12130	
FPE039	REPRESENTATIVE MODEL	VITS / VERTA / LACTIS / AURIS	INTERCHANGEABLE	NCP91 05. 02~ / SCP92 05. 11~ / NCP100 05. 10~ / NZE151H, NZE154H 06. 10~, ZRE152H, ZRE154H 06. 10~		
	PO	SP	WVA	FMSI	HP	TRW
	REAR			D1354-8463		GDB3454

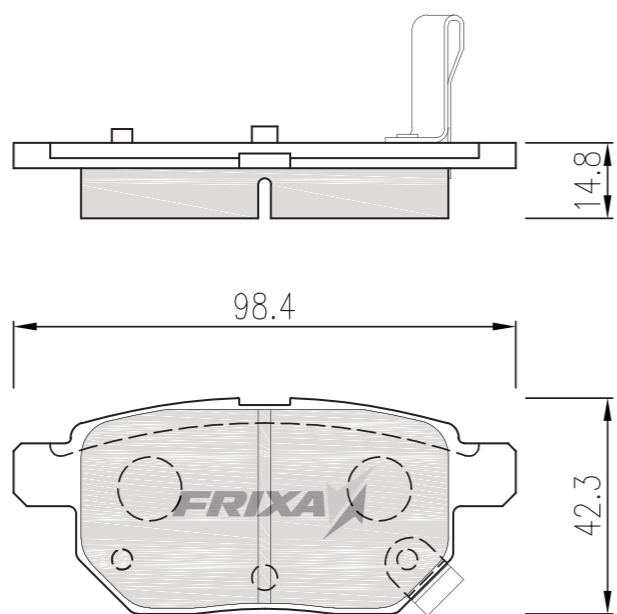

MAKER	HONDA		PART NUMBER	06430-SFE-J00		FRIXA CODE
REPRESENTATIVE MODEL	STEP WAGON / STREAM / ODYSSEY / ERISSON	INTERCHANGEABLE	RG1, RG2, RG3, RG4 05. 05~ / RN7, RN8, RN9 06. 07~ / RB1, RB2 03. 10~ / RR1, RR2, RR3, RR4 04. 05~			FPE040
PO	SP	WVA	FMSI	HP	TRW	
REAR						

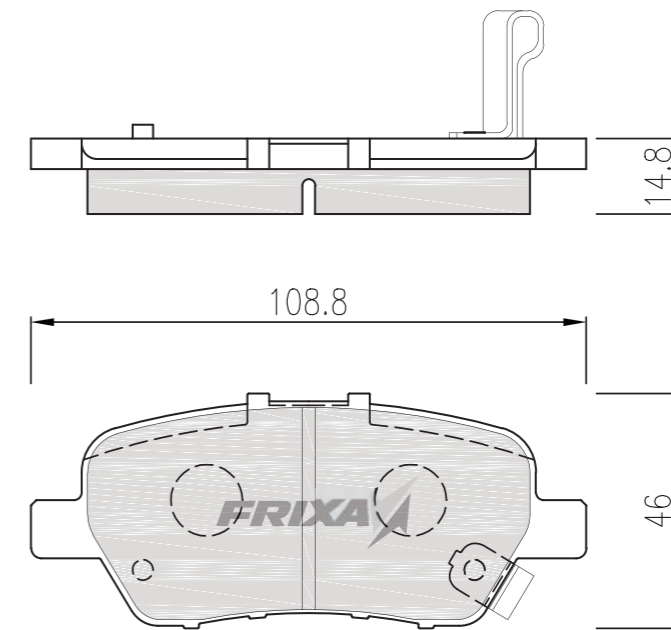

MAKER	MITSUBISHI		PART NUMBER	MB699463		FRIXA CODE
REPRESENTATIVE MODEL	LANCER	INTERCHANGEABLE	C61A, C62V, C74A, C64A(98.09~91.10)			FPE041
PO	SP	WVA	FMSI	HP	TRW	
FRONT		21650	7483-D602		GDB1129	

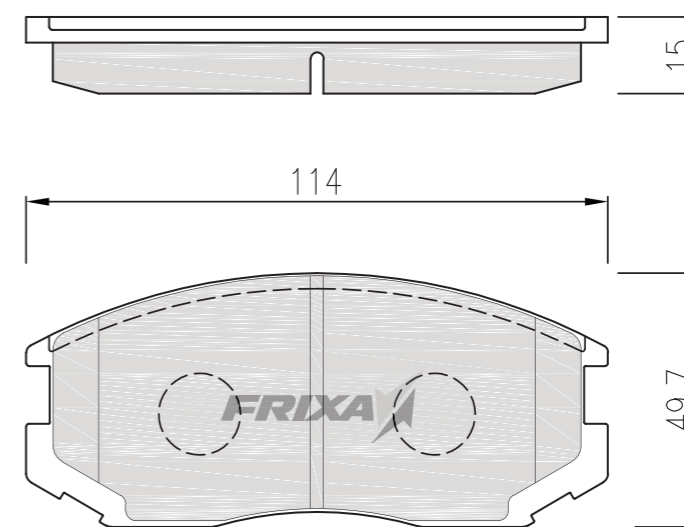

DISC BRAKE PAD

BRAKE SHOE ASSEMBLY

BRAKE LINING

DISC BRAKE PAD

BRAKE SHOE ASSEMBLY

BRAKE LINING

FRIXA CODE	MAKER	MITSUBISHI		PART NUMBER			MN102878
FPE042	REPRESENTATIVE MODEL	LANCER	INTERCHANGEABLE				
	PO	SP	WVA	FMSI	HP	TRW	
	FRONT						

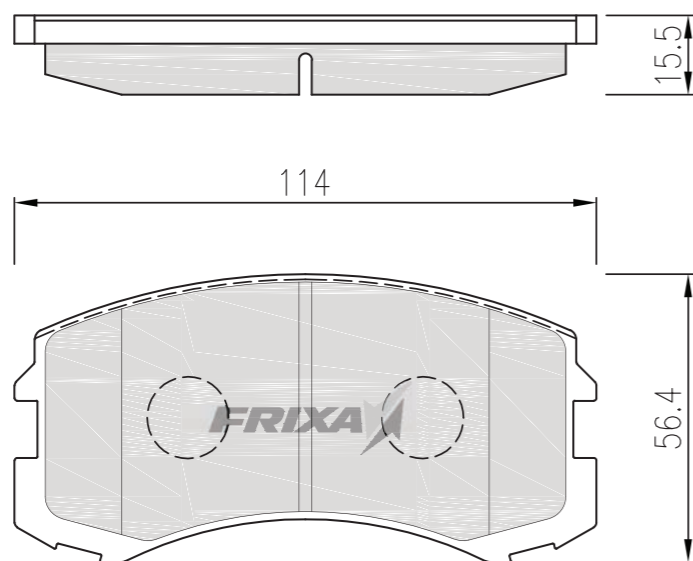

FRIXA CODE	MAKER	TOYOTA		PART NUMBER			04465-0D020
FPE043	REPRESENTATIVE MODEL	COROLLA	INTERCHANGEABLE				
	PO	SP	WVA	FMSI	HP	TRW	
	FRONT		23510	D990-7695		GDB3242	

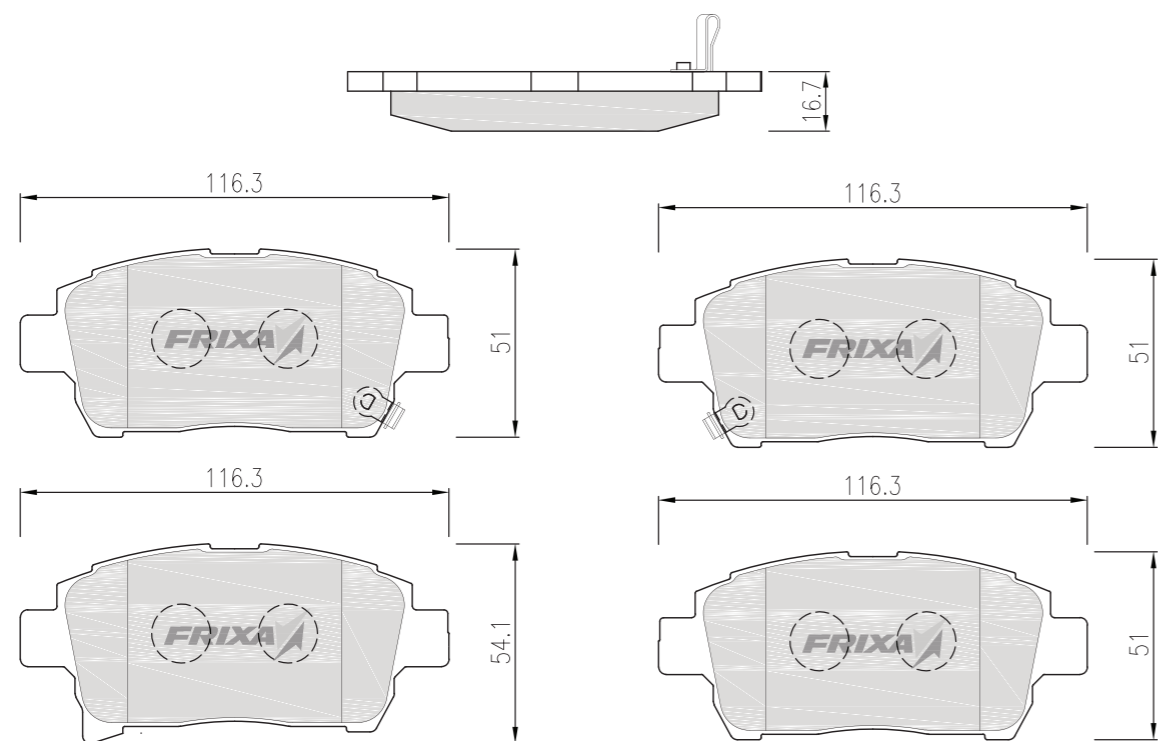

MAKER	SUZUKI		PART NUMBER			55810-68H00	FRIXA CODE
REPRESENTATIVE MODEL	CERVO / EVERY KEI / CARRY	INTERCHANGEABLE					HG21S(06.11~) DA64V, DA64W(05.08~)
PO	SP	WVA	FMSI	HP	TRW	FPE047	
FRONT							

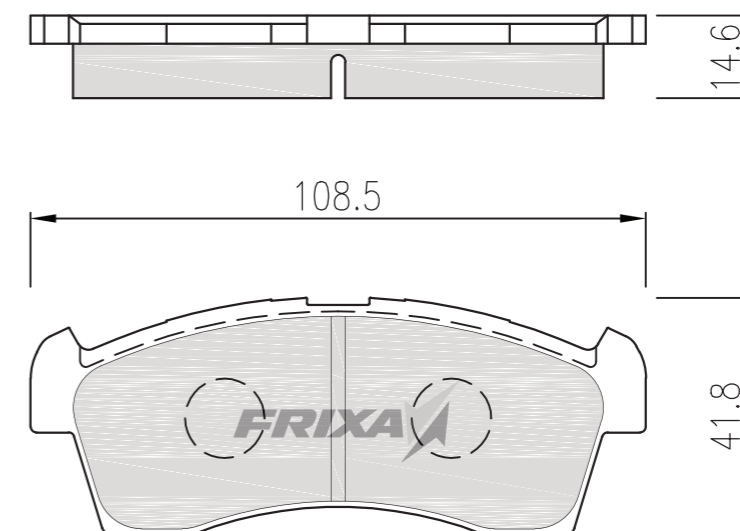

MAKER	TOYOTA		PART NUMBER			04465-02070	FRIXA CODE
REPRESENTATIVE MODEL	COROLLA AVENSIS / TRIX	INTERCHANGEABLE					CBA-ZZE122(04.02~06.01) ZZE120(02.06~)
PO	SP	WVA	FMSI	HP	TRW	FPE048	
FRONT			D923-7824		GDB3315		

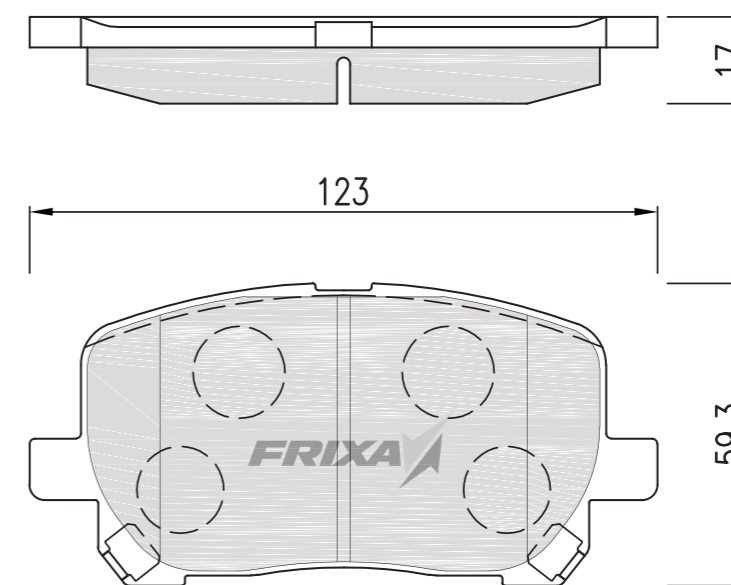

DISC BRAKE PAD

BRAKE SHOE ASSEMBLY

BRAKE LINING

DISC BRAKE PAD

BRAKE SHOE ASSEMBLY

BRAKE LINING

FRIXA CODE	MAKER	NISSAN		PART NUMBER	41060-4M490	
FPS02	REPRESENTATIVE MODEL	SUNNY	INTERCHANGEABLE	B15,FB15,FNB15(98.10~04.10) N16(00.08~04.12)		
	PO	SP	WVA	FMSI	HP	TRW
	FRONT			D1193-8311		GDB7043

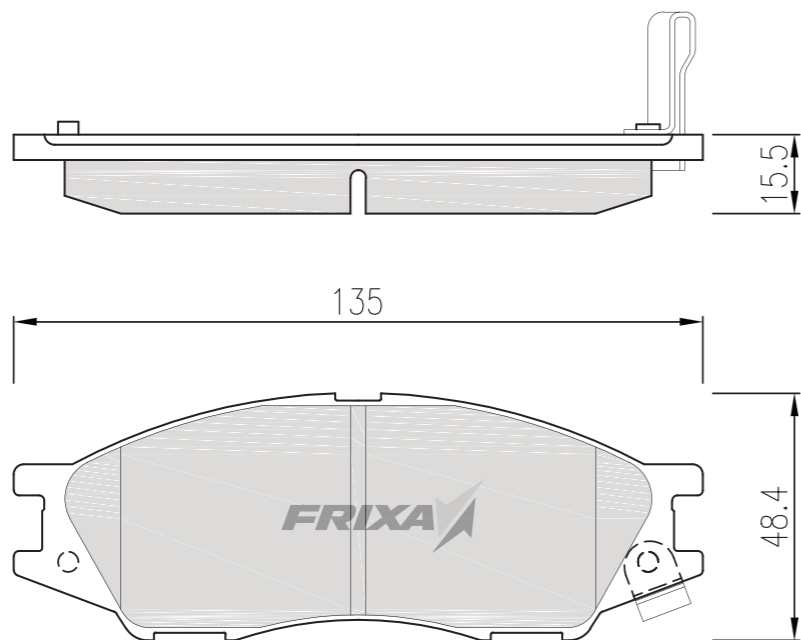

FRIXA CODE	MAKER	HONDA		PART NUMBER	45022-SFC-000	
FPE053	REPRESENTATIVE MODEL		INTERCHANGEABLE			
	PO	SP	WVA	FMSI	HP	TRW
	FRONT					

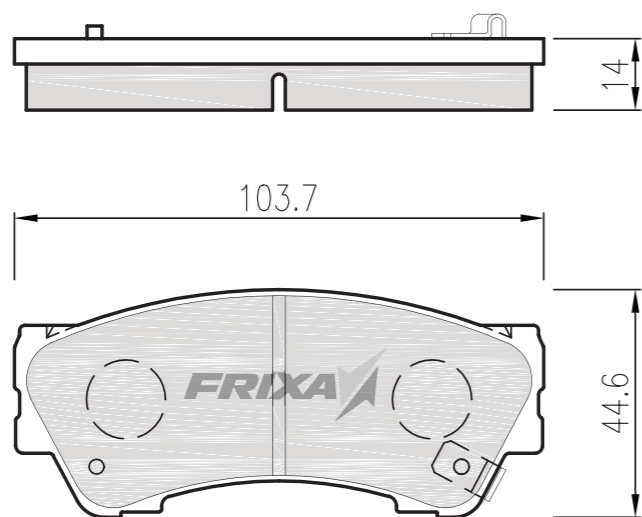

MAKER	HONDA		PART NUMBER	45022-S04-G02		FRIXA CODE
REPRESENTATIVE MODEL	MN	INTERCHANGEABLE				FPE057
PO	SP	WVA	FMSI	HP	TRW	
FRONT						

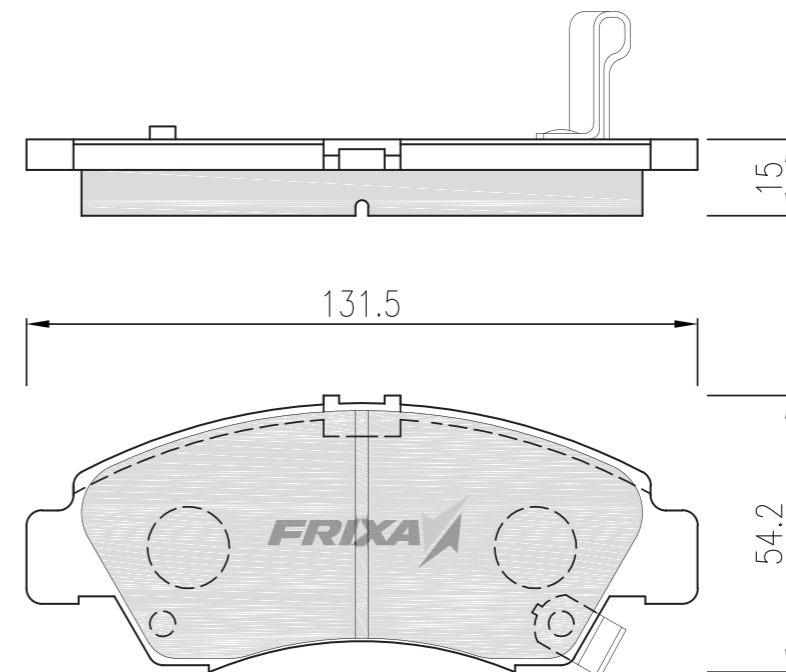

MAKER	TOYOTA		PART NUMBER	04465-12010		FRIXA CODE
REPRESENTATIVE MODEL	COROLLA	INTERCHANGEABLE	AE80(83.05~85.05) EE80(85.05~87.04)			FPE058
PO	SP	WVA	FMSI	HP	TRW	
FRONT		20870	7152-D241		GDB3184	

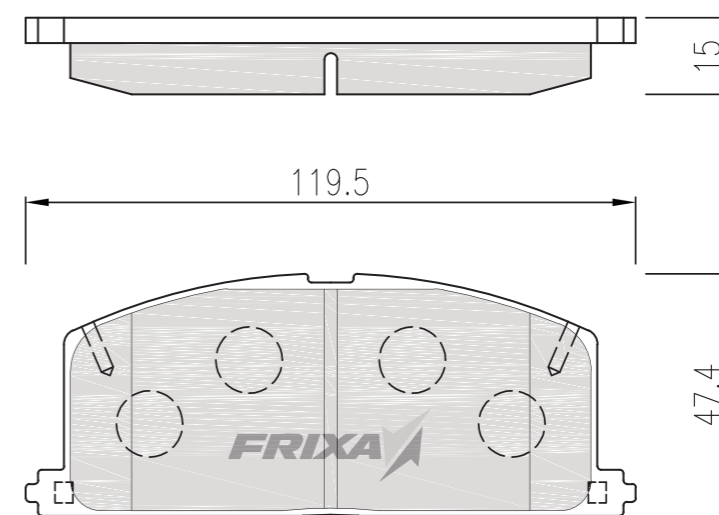

DISC BRAKE PAD

BRAKE SHOE ASSEMBLY

BRAKE LINING

DISC BRAKE PAD

BRAKE SHOE ASSEMBLY

BRAKE LINING

FRIXA CODE	MAKER	TOYOTA		PART NUMBER		04465-02170
FPE060	REPRESENTATIVE MODEL	COROLLA 2009	INTERCHANGEABLE		NZE141(06.01~08.01) NZE141G(06.01~)	
	PO	SP	WVA	FMSI	HP	TRW
	FRONT		24336			GDB3425

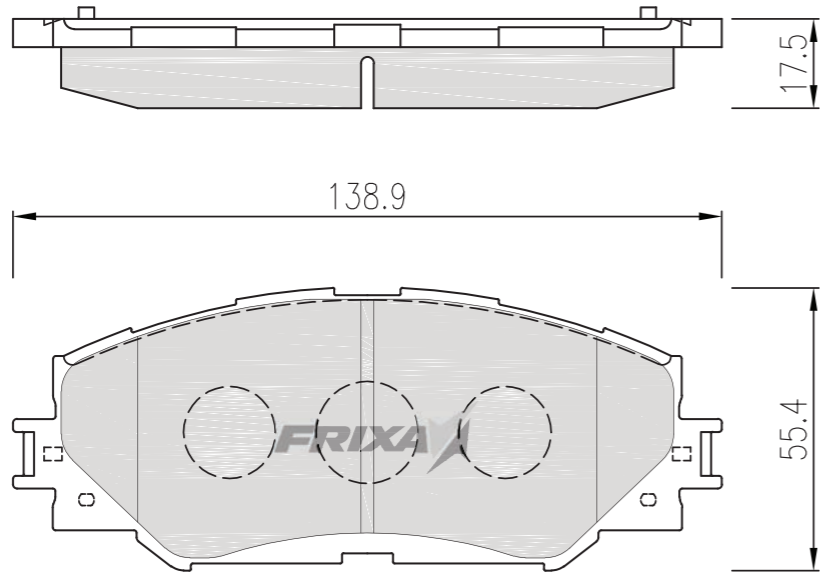

FRIXA CODE	MAKER	SUZUKI		PART NUMBER		55200-61832
FPE062	REPRESENTATIVE MODEL	CULTUS	INTERCHANGEABLE		AA44S, AB44S(88.09~98.06) AB34S, AF34S, AA34S, AB34S(88.09~00.05)	
	PO	SP	WVA	FMSI	HP	TRW
	FRONT		21730			GDB3237

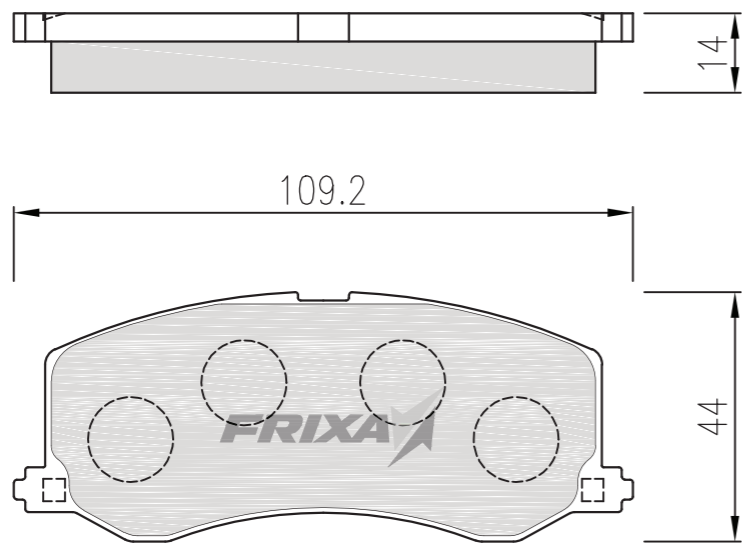

MAKER	SUZUKI		PART NUMBER		55200-56851	FRIXA CODE
REPRESENTATIVE MODEL	FX	INTERCHANGEABLE				FPD07
PO	SP	WVA	FMSI	HP	TRW	
FRONT						

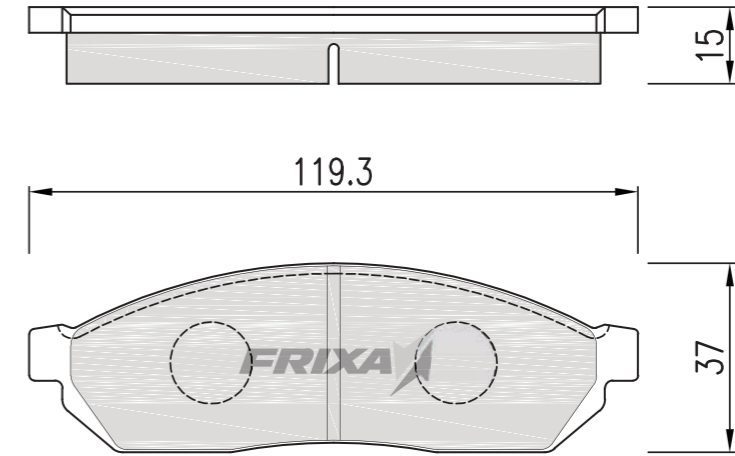

MAKER	TOYOTA		PART NUMBER		04466-20090	FRIXA CODE
REPRESENTATIVE MODEL	COROLLA REAR	INTERCHANGEABLE		ZZE120(02.01~06.10) ZZE121, CDE120(01.11~)		FPE064
PO	SP	WVA	FMSI	HP	TRW	
REAR		23521	D823-7696		GDB3243	

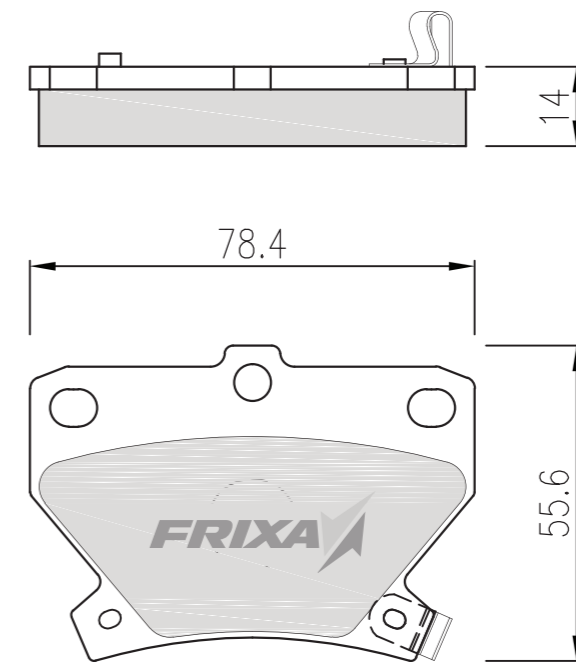

DISC BRAKE PAD

BRAKE SHOE ASSEMBLY

BRAKE LINING

DISC BRAKE PAD

BRAKE SHOE ASSEMBLY

BRAKE LINING

FRIXA CODE	MAKER	TOYOTA	PART NUMBER		04465-02160	
FPE087	REPRESENTATIVE MODEL	COROLLA 09MY(Fr)	INTERCHANGEABLE		COROLLA 09MY(Fr) (07.01~) DBA-ZRE152H(09.05~)	
	PO	SP	WVA	FMSI	HP	TRW
	FRONT					GDB3481

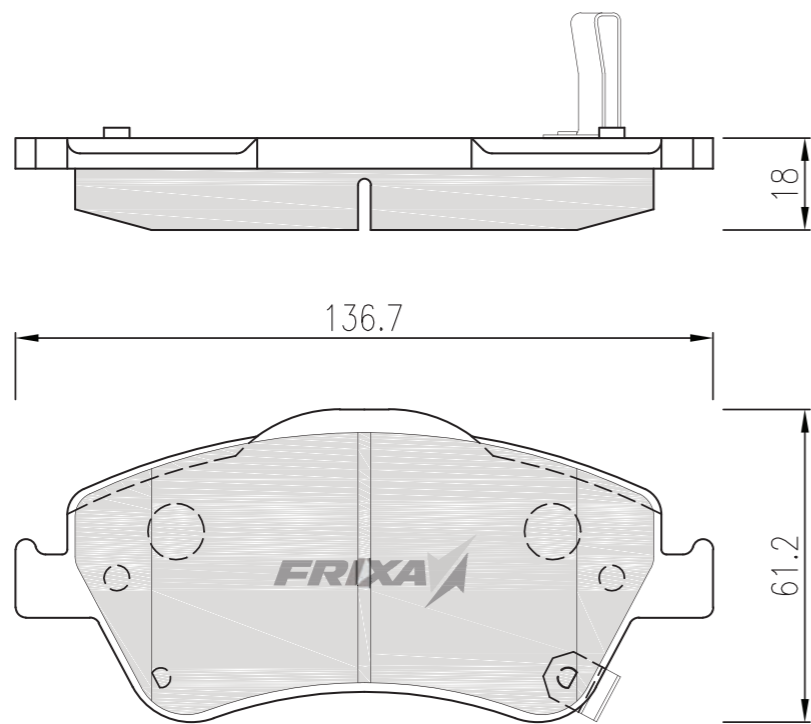

FRIXA CODE	MAKER	TOYOTA	PART NUMBER		04466-02170	
FPE088	REPRESENTATIVE MODEL	COROLLA 09MY(Fr) AURIS	INTERCHANGEABLE		COROLLA 09MY(Fr) (07.01~) DBA-ZRE152H(09.05~)	
	PO	SP	WVA	FMSI	HP	TRW
	REAR					

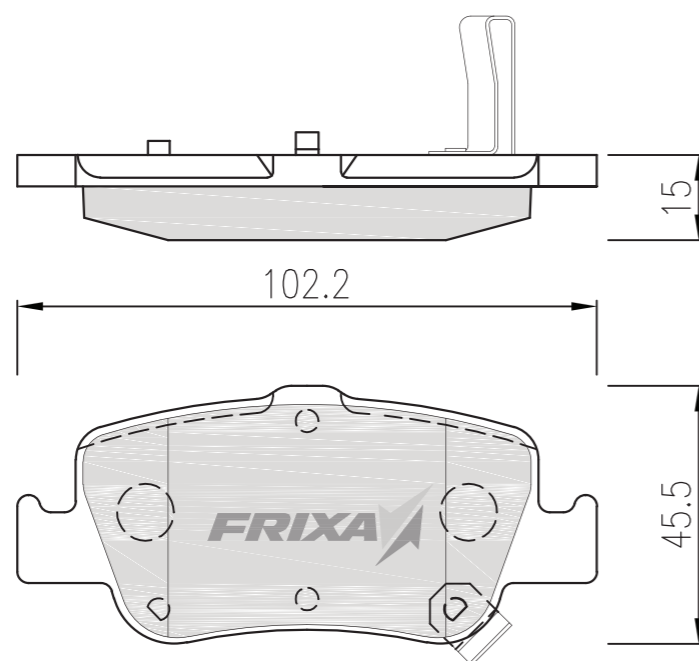

MAKER	TOYOTA	PART NUMBER		04466-05010		FRIXA CODE
REPRESENTATIVE MODEL	AVENSIS ESTIMA	INTERCHANGEABLE		ZZT250,ZZT251(03.03~08.01) DAA-AHR20W(06.06~)		FPE089
PO	SP	WVA	FMSI	HP	TRW	
REAR					GDB3337	

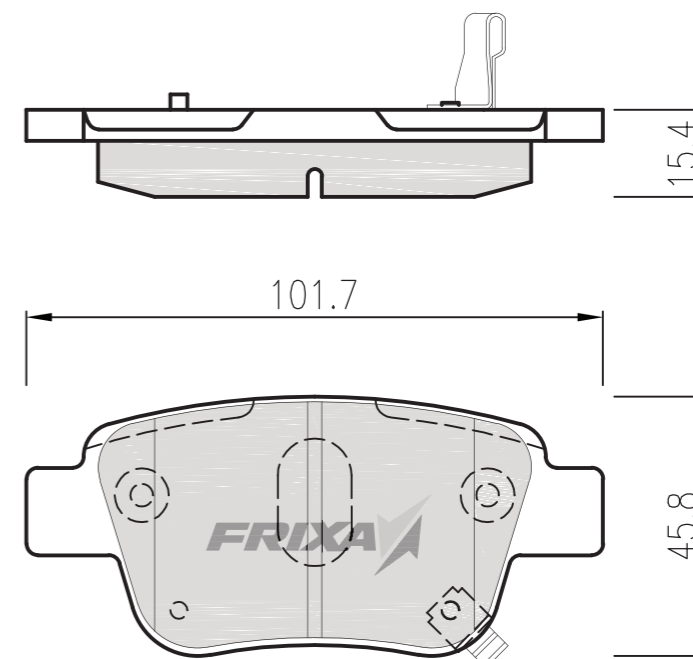

MAKER	TOYOTA	PART NUMBER		04465-52230		FRIXA CODE
REPRESENTATIVE MODEL	COROLLA	INTERCHANGEABLE		ZZE121(01.11~) CE121G,CE121(00.08~04.01)		FPE090
PO	SP	WVA	FMSI	HP	TRW	
FRONT		23510	7695-D822		GDB3242	

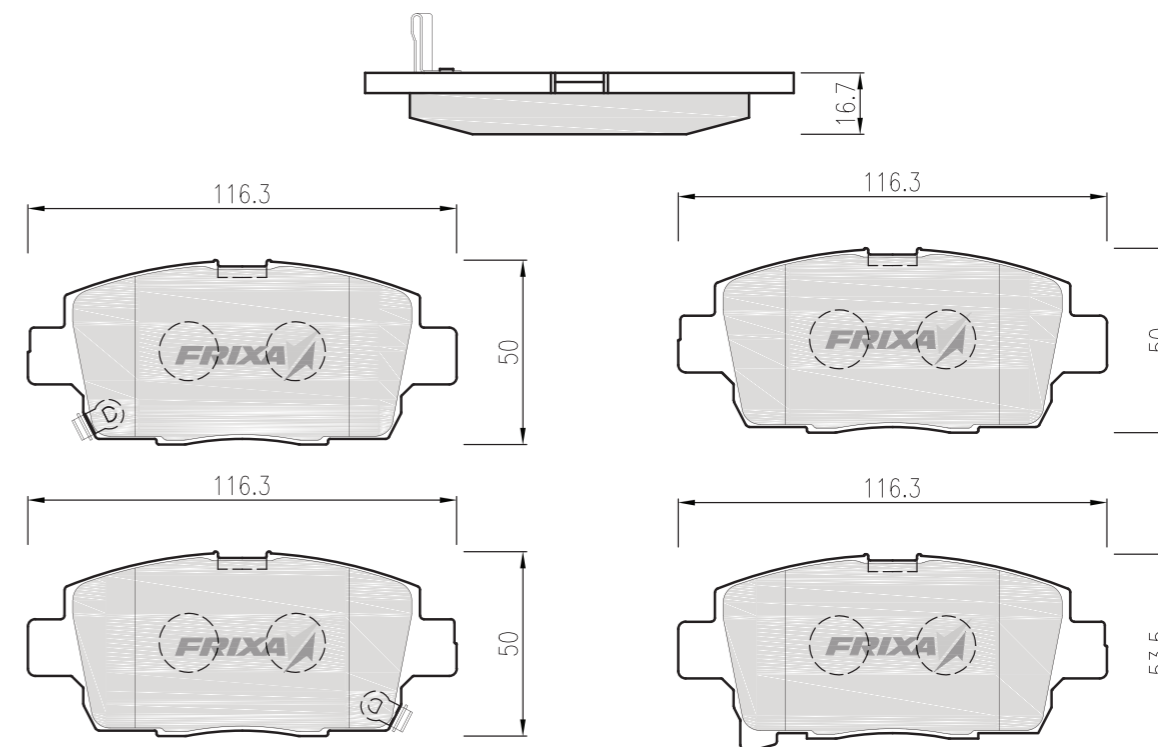

DISC BRAKE PAD

BRAKE SHOE ASSEMBLY

BRAKE LINING

DISC BRAKE PAD

BRAKE SHOE ASSEMBLY

BRAKE LINING

FRIXA CODE	MAKER	TOYOTA		PART NUMBER		04465-28520
FPE091	REPRESENTATIVE MODEL	ALPHARD ESTIMA	INTERCHANGEABLE	ANH20W,25W,GGH20W,25W(08.05~)		
	PO	SP	WVA	FMSI	HP	TRW
	FRONT					

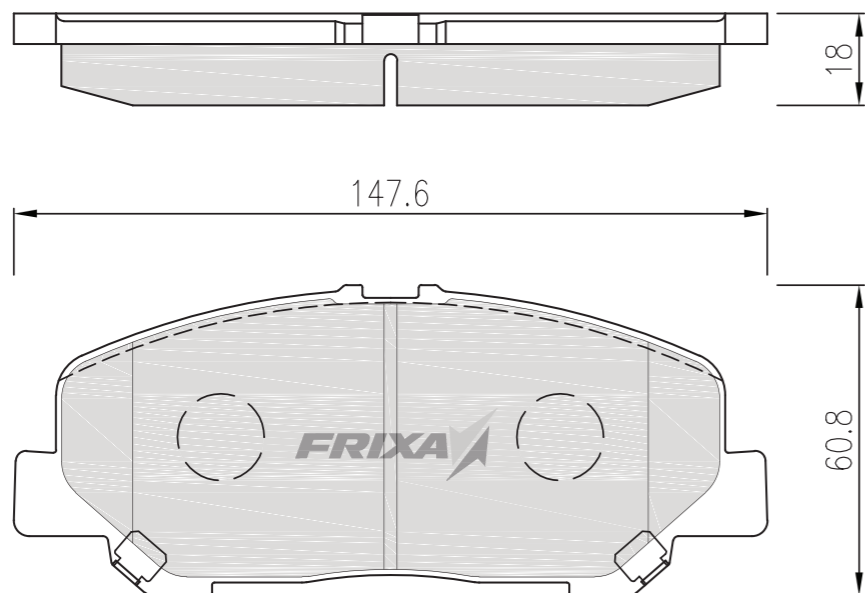

FRIXA CODE	MAKER	SUZUKI		PART NUMBER		55810-57K00
FPE092	REPRESENTATIVE MODEL	SWIFT	INTERCHANGEABLE	ZC71S(07.05~) ZC11S,ZC21S,ZD11S,ZD21S(04.11~)		
	PO	SP	WVA	FMSI	HP	TRW
	FRONT					

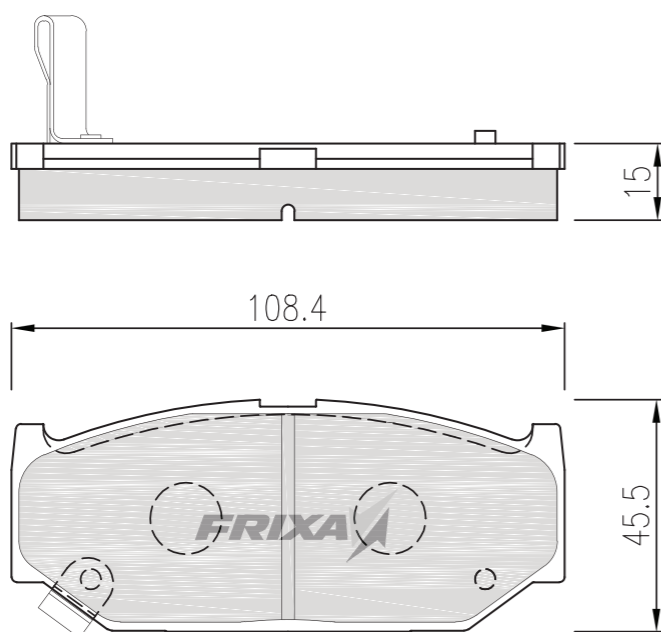

MAKER	SUZUKI		PART NUMBER		55110-80000	FRIXA CODE
REPRESENTATIVE MODEL	JIMNY	INTERCHANGEABLE	SJ30(84.07~87.12) JA71C,JA71V(86.01~90.03)			FPE096
PO	SP	WVA	FMSI	HP	TRW	
FRONT			7540-D660		GDB3210	

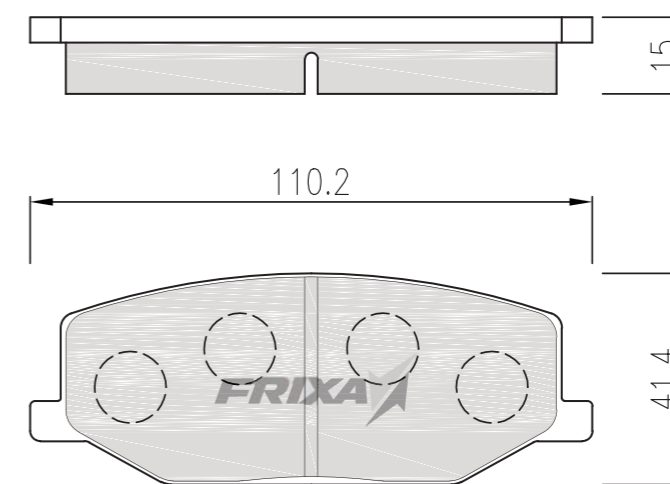

MAKER	TOYOTA		PART NUMBER		04466-28010	FRIXA CODE
REPRESENTATIVE MODEL	ESTIMA	INTERCHANGEABLE	CXR10G,11G,20G,21G,TCR20 G(W),21W(93.08~95.01)			FPE097
PO	SP	WVA	FMSI	HP	TRW	
REAR		21688			GDB1138	

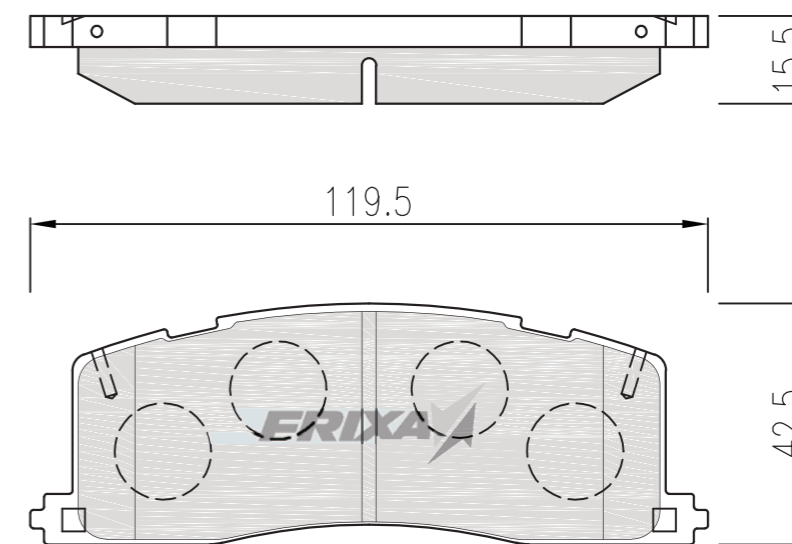

DISC BRAKE PAD

BRAKE SHOE ASSEMBLY

BRAKE LINING

DISC BRAKE PAD

BRAKE SHOE ASSEMBLY

BRAKE LINING

FRIXA CODE	MAKER	SUBARU		PART NUMBER	25296-FA041	
FPE098	REPRESENTATIVE MODEL	IMPREZA, LEGACY, FORESTER	INTERCHANGEABLE	GF8, GC8(96.09~00.07) BG5(96.06~98.11)		
	PO	SP	WVA	FMSI	HP	TRW
	FRONT		21915	7589-D721		GDB3217

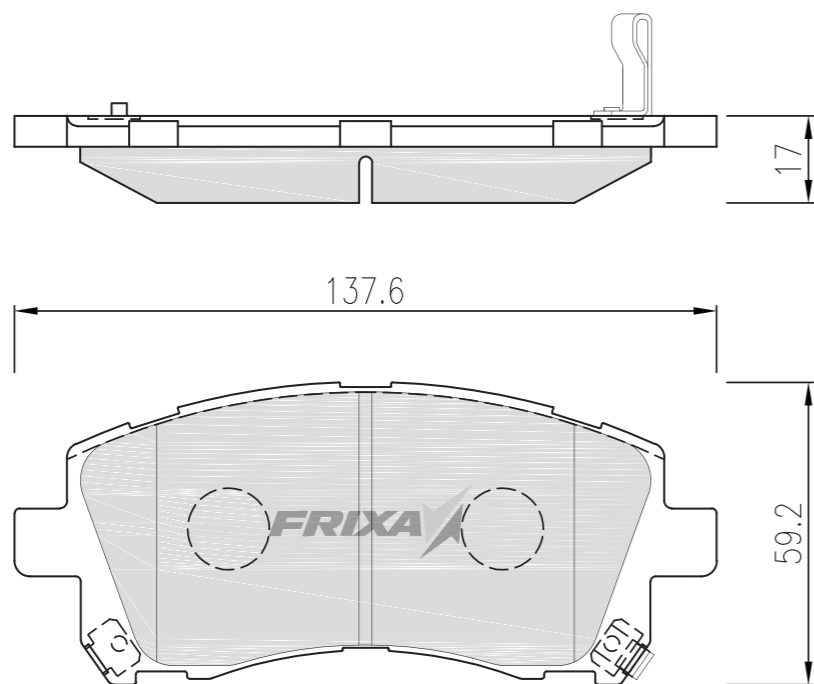

FRIXA CODE	MAKER	DAIHATSU		PART NUMBER	04465-B1050	
FPE099	REPRESENTATIVE MODEL	MIRA, MOVE, TANTO	INTERCHANGEABLE	L275S, L285S(06.12~) L185S(06.10~)		
	PO	SP	WVA	FMSI	HP	TRW
	FRONT					

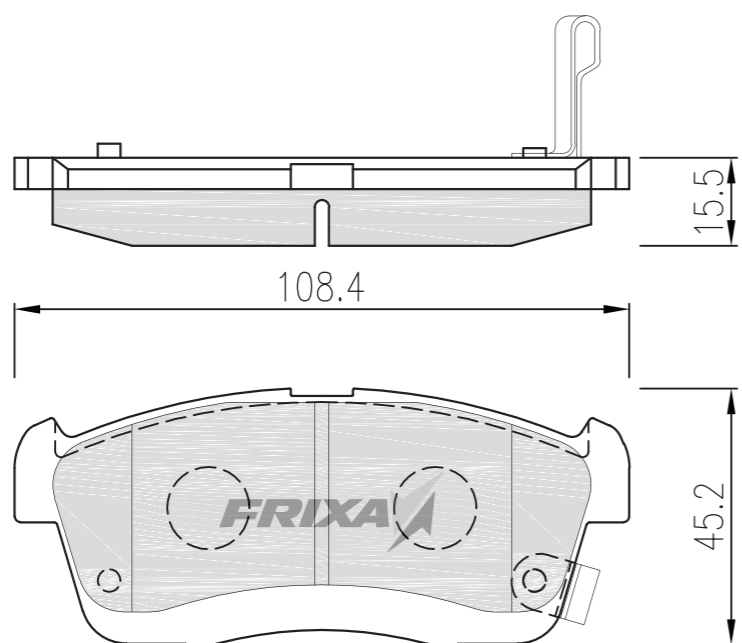

MAKER	RENAULT		PART NUMBER	60 00 008 126		FRIXA CODE
REPRESENTATIVE MODEL	CLIO, MEGANE	INTERCHANGEABLE	557W(94.06~98.02) EA0W(99.03~00.09)			FPE100
PO	SP	WVA	FMSI	HP	TRW	
FRONT		21404	7194-D292		GDB1332	

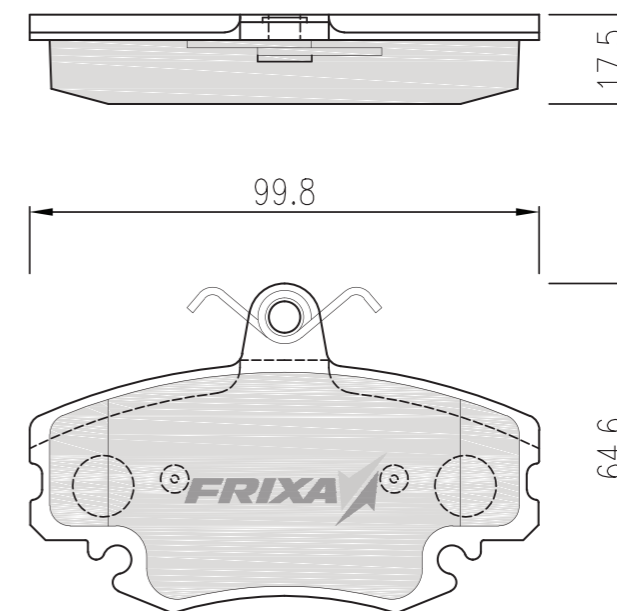

MAKER	FORD / AZDA		PART NUMBER	3M51-2K021-44		FRIXA CODE
REPRESENTATIVE MODEL	FOCUSII / AZDA3	INTERCHANGEABLE	BK12, BK14(03.10~09.01)			FPE101
PO	SP	WVA	FMSI	HP	TRW	
FRONT	SP1260	23723	7947-D1230		GDB1583	

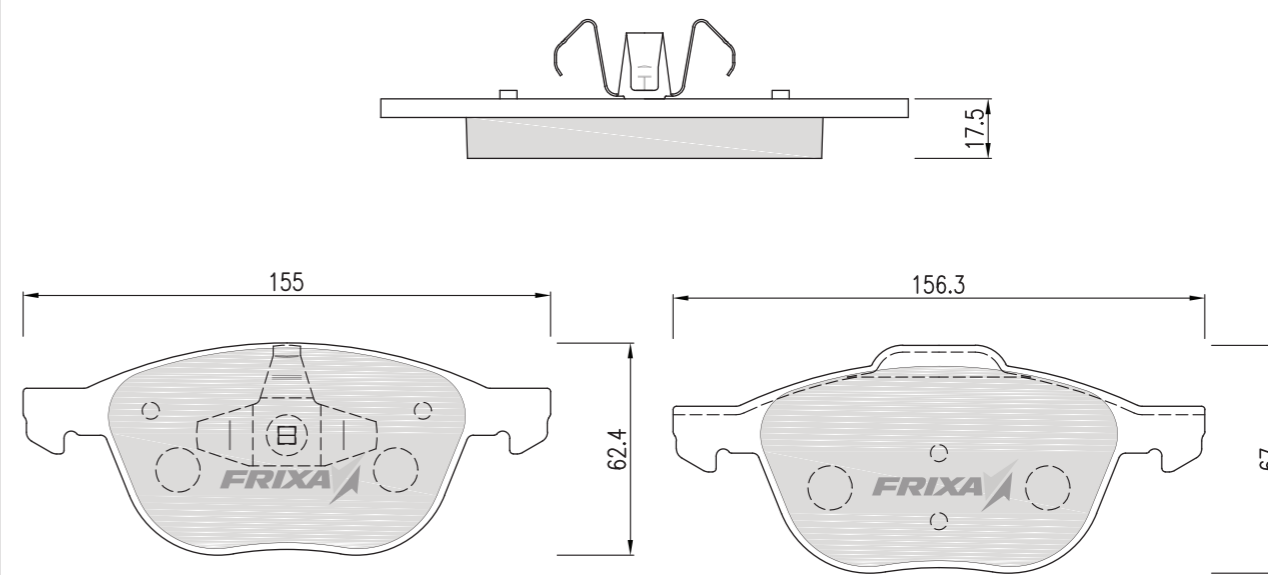

DISC BRAKE PAD

BRAKE SHOE ASSEMBLY

BRAKE LINING

DISC BRAKE PAD

BRAKE SHOE ASSEMBLY

BRAKE LINING

FRIXA CODE	MAKER	FORD / MAZDA		PART NUMBER		2T1422M008AA
FPE102	REPRESENTATIVE MODEL	FOCUSII / AZDA3	INTERCHANGEABLE		BK12, BK14(03.10~09.01)	
	PO	SP	WVA	FMSI	HP	TRW
	REAR	SP2091	23482	7957-D1095		GDB1621

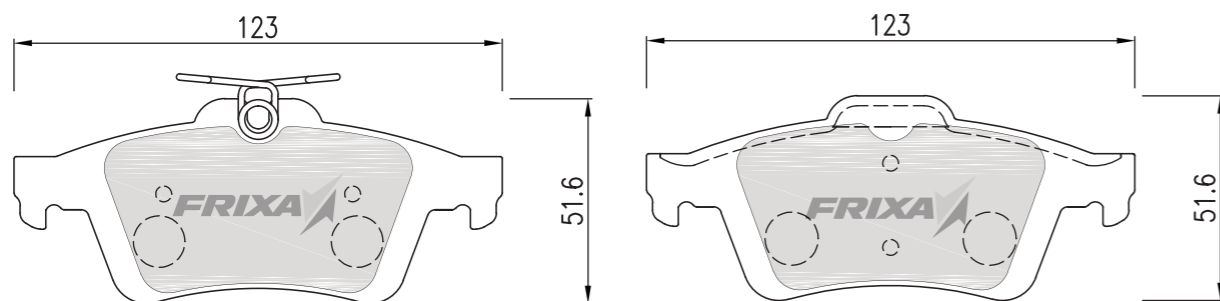
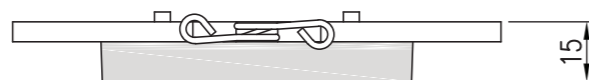

FRIXA CODE	MAKER	LADA		PART NUMBER		2108-3501089
FPE103	REPRESENTATIVE MODEL	VAZ 2108	INTERCHANGEABLE		CEVARO(90.~93.) SAMARA (VAZ 2108/2109)(86.~96.) SAMARA FORMA / DIVA / SAGONA (VAZ 21099)(88.~97.)	
	PO	SP	WVA	FMSI	HP	TRW
	FRONT	SP1165	20789			GDB469

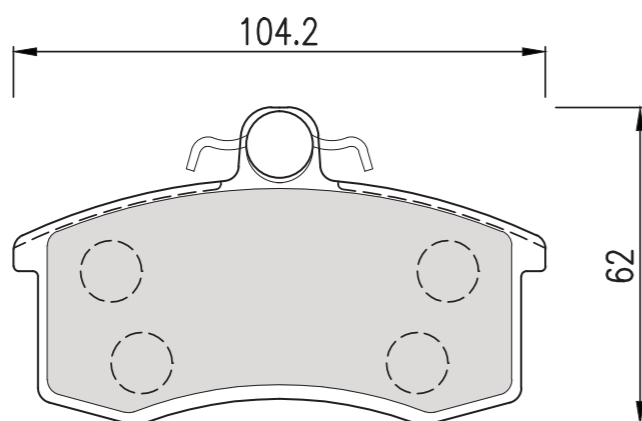
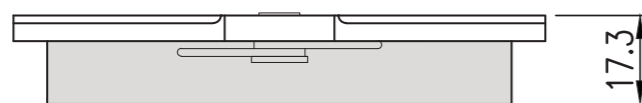

MAKER	LADA		PART NUMBER		2108-3501080	FRIXA CODE
REPRESENTATIVE MODEL	VAZ 2110	INTERCHANGEABLE		110 (VAZ 2110)(96.~00.) / 111 (VAZ 2111)(96.~00.) NOVA - KALINA (VAZ 2105/2107)(94.~00.) SAMARA (VAZ 2108/2109)(95.~00.)		FPE104
PO	SP	WVA	FMSI	HP	TRW	
FRONT	SP1181	23670			GDB1446	

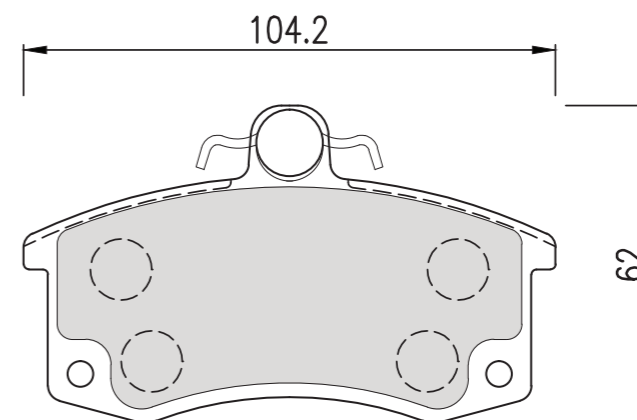
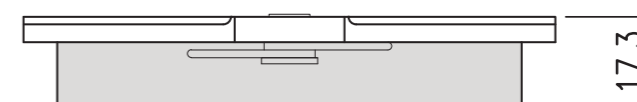

MAKER	LADA		PART NUMBER		2121-3501090	FRIXA CODE
REPRESENTATIVE MODEL	NIVA 2121	INTERCHANGEABLE		COSSACK(78.~96.) NIVA (VAZ 2121)1.6/1.7(76.~00.) TAIGA(77.~00.)		FPE105
PO	SP	WVA	FMSI	HP	TRW	
FRONT	SP1168	20660			GDB265	

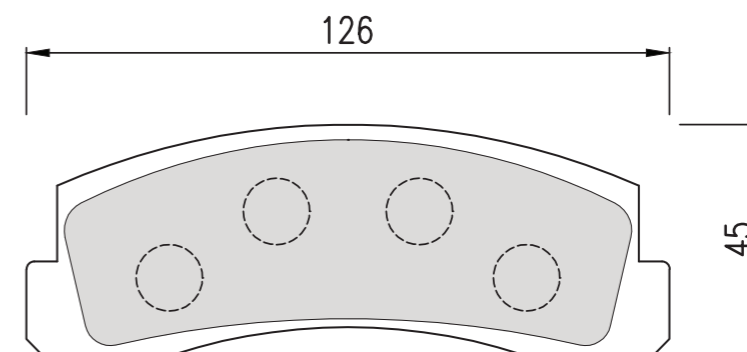
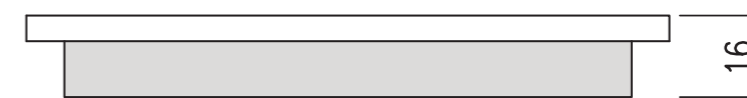

DISC BRAKE PAD

BRAKE SHOE ASSEMBLY

BRAKE LINING

DISC BRAKE PAD

BRAKE SHOE ASSEMBLY

BRAKE LINING

FRIXA CODE	MAKER	LADA		PART NUMBER		
FPE106	REPRESENTATIVE MODEL	WHA 2101-2107	INTERCHANGEABLE			NOVA - KALINA (VAZ 2105/2107)(81.~00.) RIVA ESTATE (VAZ 2101/2102/2103/2106)(73.~85.) TOSCANA (VAZ 2107)(83.~92.)
	PO	SP	WVA	FMSI	HP	TRW
	FRONT	SP1199	20166			

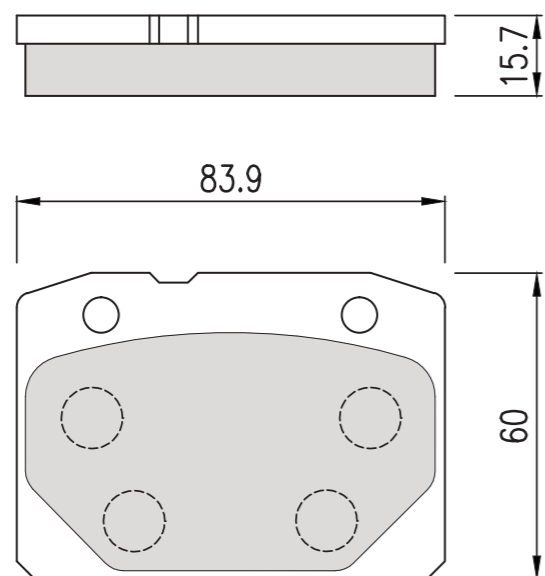

FRIXA CODE	MAKER	GAZ		PART NUMBER		
FPE107	REPRESENTATIVE MODEL	VOLGA	INTERCHANGEABLE			GAZELLE
	PO	SP	WVA	FMSI	HP	TRW
	FRONT	SP1200				GDB851

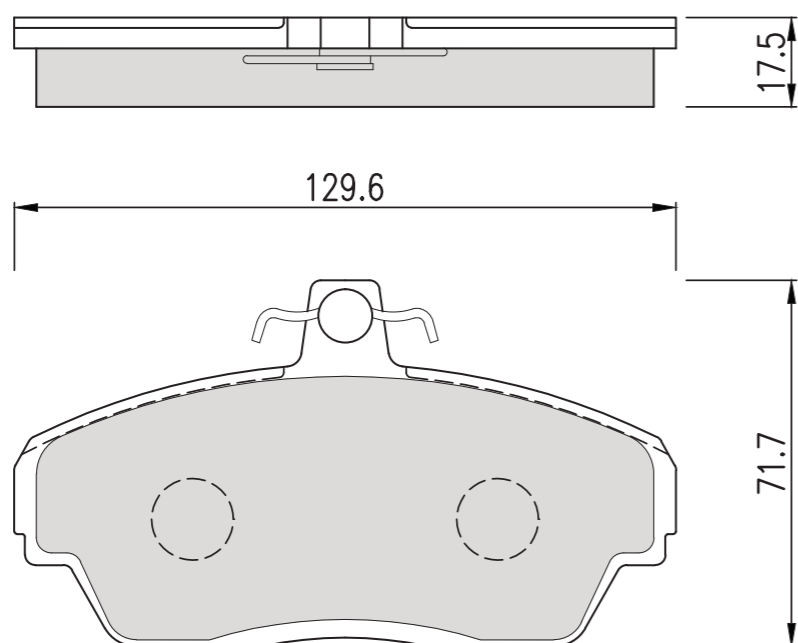

MAKER	MERCEDES BENZ		PART NUMBER			FRIXA CODE
REPRESENTATIVE MODEL	SPRINTER	INTERCHANGEABLE			SPRINTER (904)(96.~03.)	FPE108
PO	SP	WVA	FMSI	HP	TRW	
FRONT / REAR	SP1245	29076	D949-7848		GDB1288	

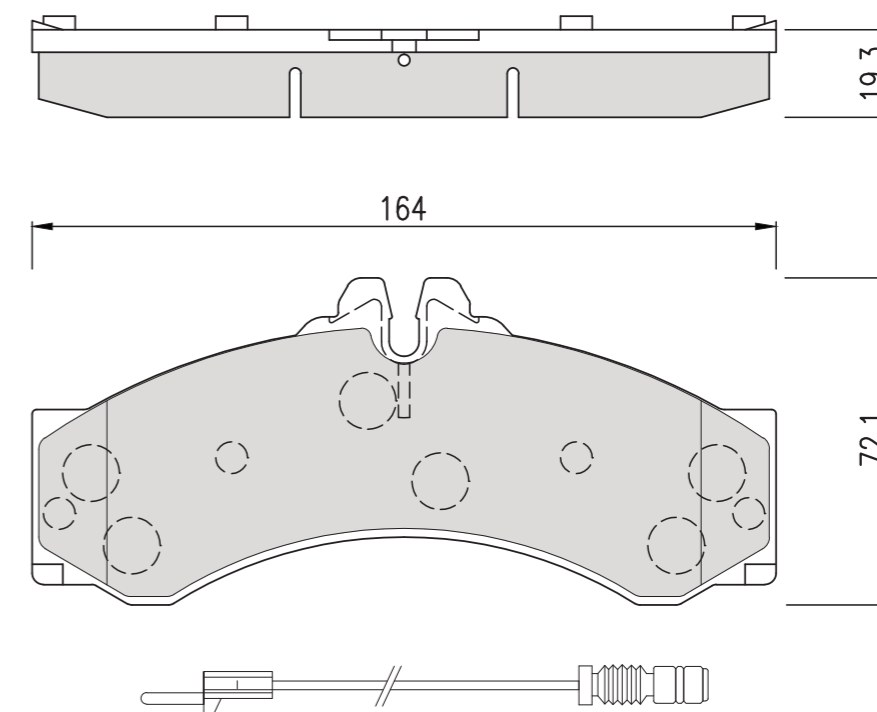

MAKER	AUDI / VOLKSWAGEN		PART NUMBER			FRIXA CODE
REPRESENTATIVE MODEL	A4 / GOLF	INTERCHANGEABLE				FPE109
PO	SP	WVA	FMSI	HP	TRW	
FRONT	SP2001	20676	D840-7711		GDB1049	

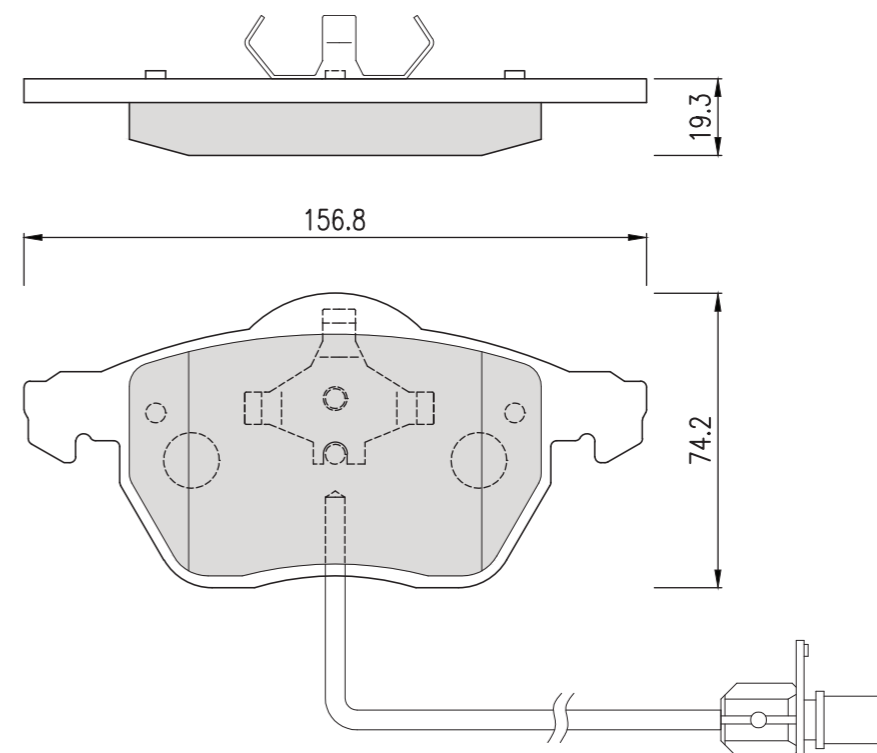

DISC BRAKE PAD

BRAKE SHOE ASSEMBLY

BRAKE LINING

DISC BRAKE PAD

BRAKE SHOE ASSEMBLY

BRAKE LINING

FRIXA CODE	MAKER	AUDI, PEUGEOT, RENAULT, VOLKSWAGEN	PART NUMBER	4B0698151AB		
FPE110	REPRESENTATIVE MODEL	A4, 405, MEGANE, GOLF	INTERCHANGEABLE	A3, A6		
	PO	SP	WVA	FMSI	HP	TRW
	REAR	SP2029	20261	D340-7234		GDB1196

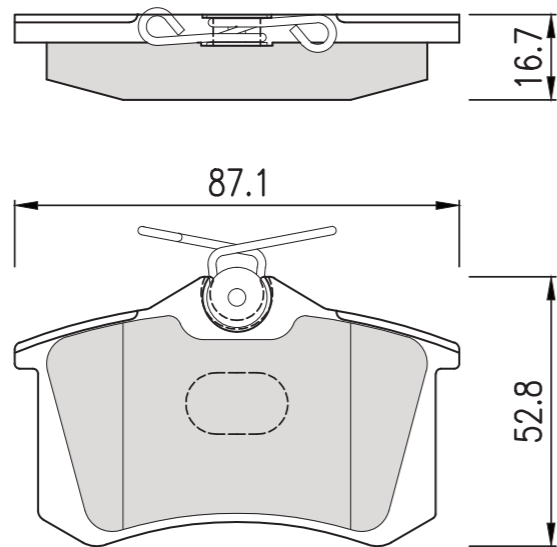

FRIXA CODE	MAKER		PART NUMBER			
	REPRESENTATIVE MODEL		INTERCHANGEABLE			
	PO	SP	WVA	FMSI	HP	TRW
	FRONT					

DISC BRAKE PAD

BRAKE SHOE ASSEMBLY

BRAKE LINING



FRIXA BRAKE SYSTEM

BRAKE SHOE ASSEMBLY

HYUNDAI	(REAR)	P. 146 ~
KIA	(REAR)	P. 153 ~
CHEVROLET	(REAR)	P. 163 ~
SAMSUNG	(REAR)	P. 167 ~
Light Truck		P. 169 ~

FRIXA BRAKE SYSTEM
BRAKE SHOE ASSEMBLY
We guarantee accurate and safe braking

FRIXA CODE	MAKER	HYUNDAI	PART NUMBER		58305-17A00	
FLH01	REPRESENTATIVE MODEL	AVANTE	INTERCHANGEABLE	AVANTE, VERNA NEW, ELANTRA TIBURON, AVANTE XD, AVANTE 06MY		
	PO	SP	WVA	FMSI	HP	TRW
	REAR	SA062			HS0002	
				OUTSIDE RADIUS (mm)	100.1	
				WIDTH OF LINING (mm)	36.0	

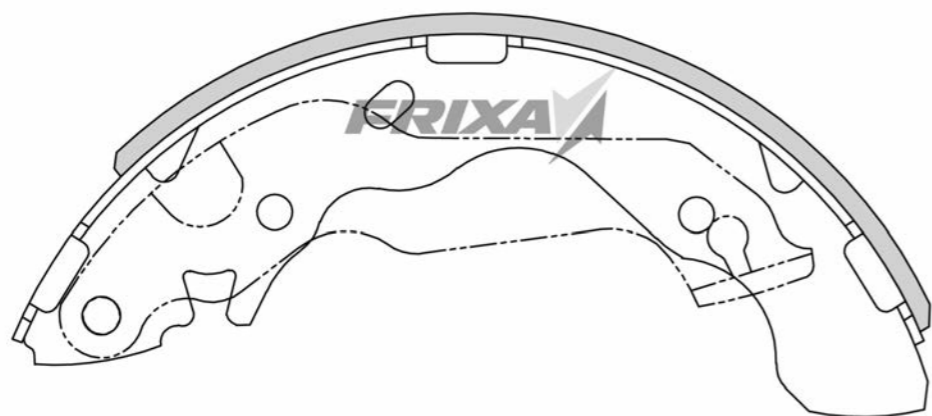

FRIXA CODE	MAKER	HYUNDAI	PART NUMBER		58305-24000	
FLH012	REPRESENTATIVE MODEL	EXCEL	INTERCHANGEABLE	EXCEL, SCOUPE, VERNA OLD		
	PO	SP	WVA	FMSI	HP	TRW
	REAR	SA046			HS0001	
				OUTSIDE RADIUS (mm)	89.4	
				WIDTH OF LINING (mm)	35.0	

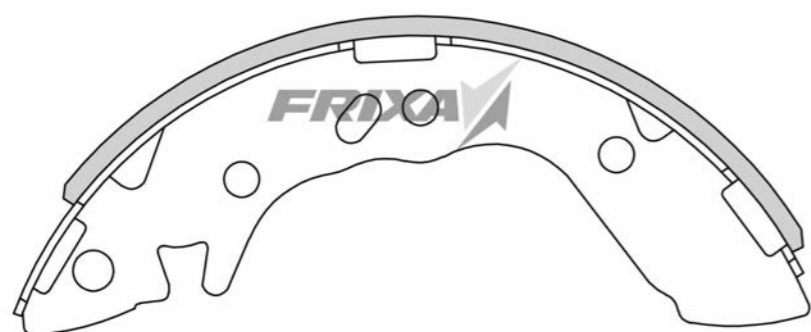

MAKER	HYUNDAI	PART NUMBER		58305-22A00		FRIXA CODE
REPRESENTATIVE MODEL	ACCENT	INTERCHANGEABLE	ACCENT			FLH013
PO	SP	WVA	FMSI	HP	TRW	
REAR	SA047			HS0003		
		OUTSIDE RADIUS (mm)	89.7			
		WIDTH OF LINING (mm)	30.0			

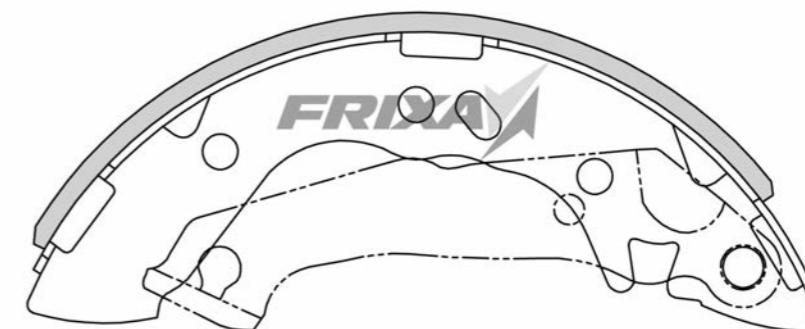

MAKER	HYUNDAI	PART NUMBER		58305-34A10		FRIXA CODE
REPRESENTATIVE MODEL	SONATA	INTERCHANGEABLE	SONATA I / II / III STELLA, CARSTAR			FLH02
PO	SP	WVA	FMSI	HP	TRW	
REAR	SA048			HS0005		
		OUTSIDE RADIUS (mm)	113.0			
		WIDTH OF LINING (mm)	42.0			

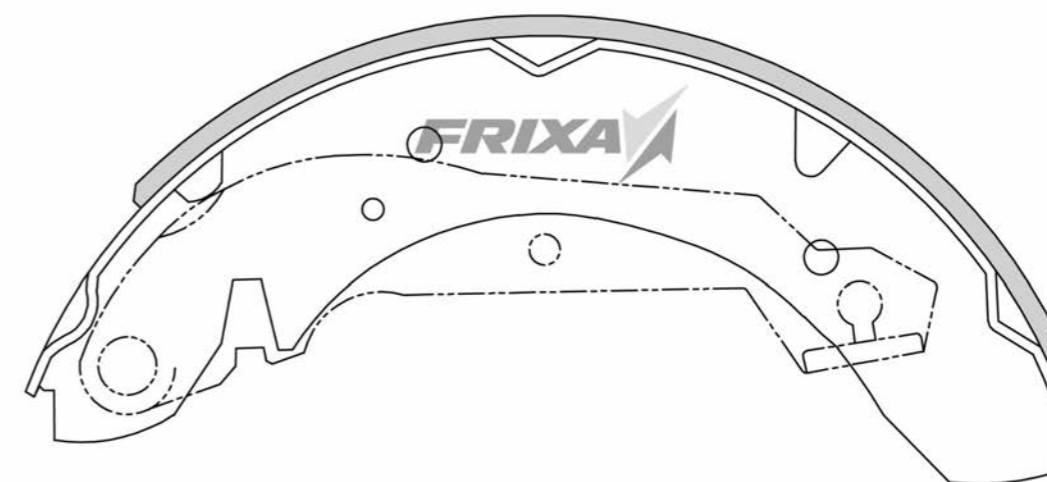

DISC BRAKE PAD

DISC BRAKE PAD

DISC BRAKE PAD

DISC BRAKE PAD

DISC BRAKE PAD

DISC BRAKE PAD

FRIXA CODE	MAKER	HYUNDAI	PART NUMBER		58305-38A00	
FLH02F	REPRESENTATIVE MODEL	EF SONATA	INTERCHANGEABLE		EF SONATA, LAVITA SANTAMO, OPTIMA	
	PO	SP	WVA	FMSI	HP	TRW
	REAR	SA111			HS0007	
					OUTSIDE RADIUS (mm)	113.0
					WIDTH OF LINING (mm)	42.0

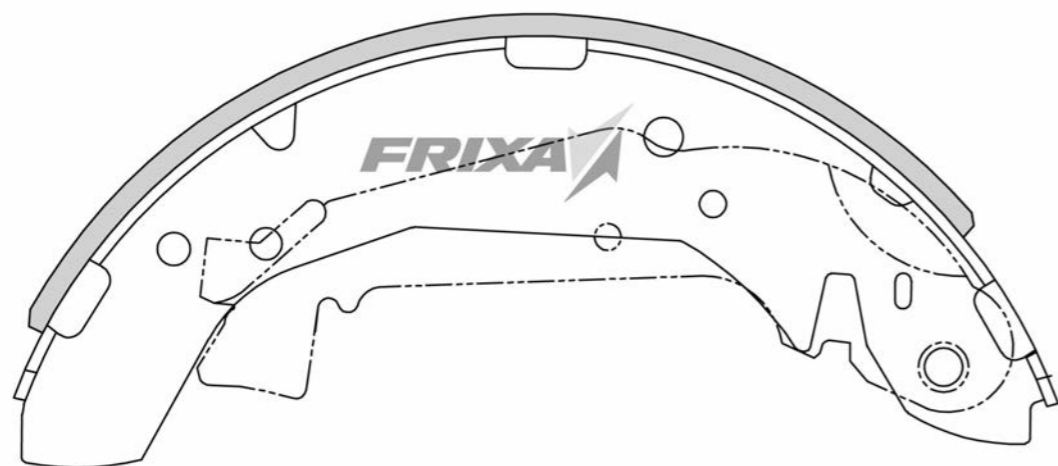

FRIXA CODE	MAKER	HYUNDAI	PART NUMBER		48250-01000	
FLH06	REPRESENTATIVE MODEL	NEW GRACE	INTERCHANGEABLE		NEW GRACE, GALLOPER, MUSSON ISTANA, NEW KORANDO, REXTON KYRON, ACTYON, KORANDO FAMILY	
	PO	SP	WVA	FMSI	HP	TRW
	REAR	SA072-GR			HS0012	
					OUTSIDE RADIUS (mm)	125.8
					WIDTH OF LINING (mm)	55.4



MAKER	HYUNDAI	PART NUMBER		58305-4BA00		FRIXA CODE
REPRESENTATIVE MODEL	PORTER	INTERCHANGEABLE		PORTER		FLH07
PO	SP	WVA	FMSI	HP	TRW	
REAR	SA072-PO			HS0011		
					OUTSIDE RADIUS (mm)	109.8
					WIDTH OF LINING (mm)	45.0

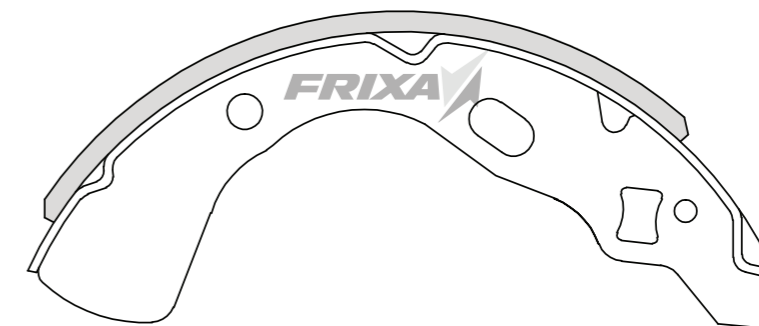

MAKER	HYUNDAI	PART NUMBER		58305-4AA00		FRIXA CODE
REPRESENTATIVE MODEL	STAREX	INTERCHANGEABLE		STAREX, GALLOPER II		FLH09
PO	SP	WVA	FMSI	HP	TRW	
REAR	SA099			HS0009		
					OUTSIDE RADIUS (mm)	134.7
					WIDTH OF LINING (mm)	52.0

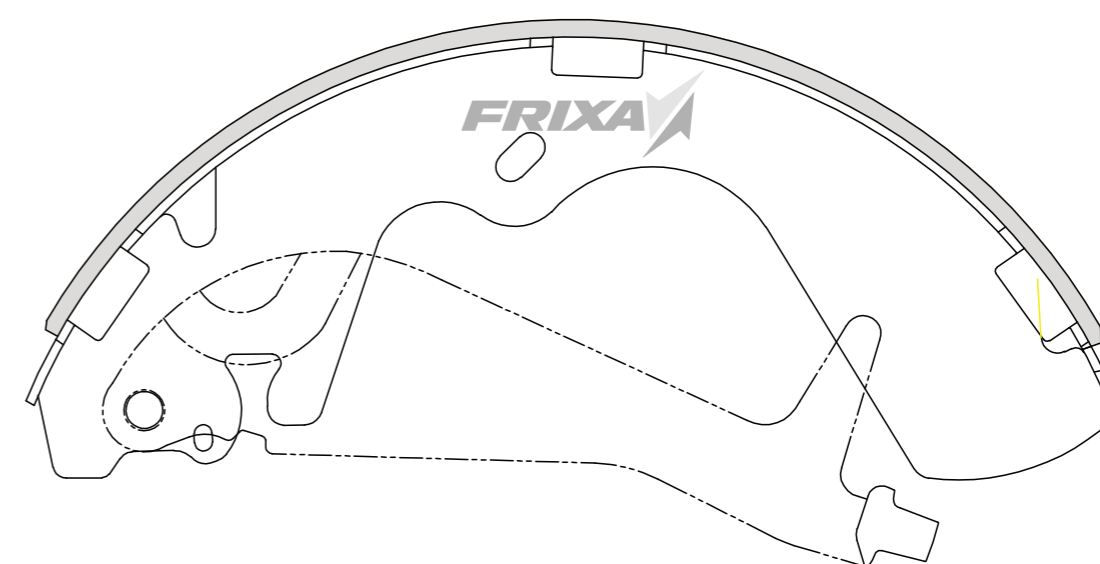

DISC BRAKE PAD

DISC BRAKE PAD

DISC BRAKE PAD

DISC BRAKE PAD

DISC BRAKE PAD

DISC BRAKE PAD

FRIXA CODE	MAKER	HYUNDAI	PART NUMBER		58305-02500	
FLH10	REPRESENTATIVE MODEL	ATOZ	INTERCHANGEABLE	ATOZ, VISTO		
	PO	SP	WVA	FMSI	HP	TRW
	REAR	SA096			HS0008	
				OUTSIDE RADIUS (mm)	90.1	
				WIDTH OF LINING (mm)	30.0	

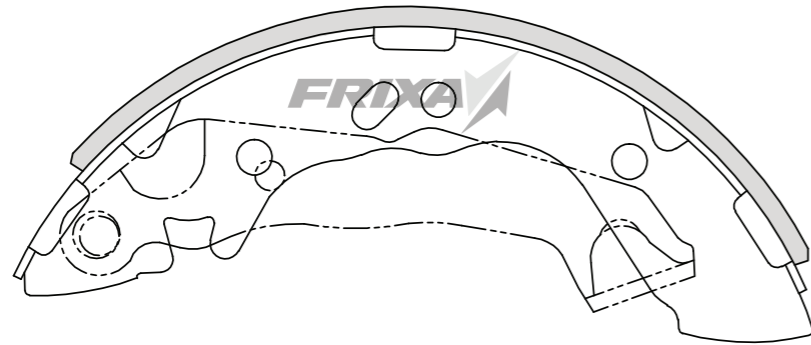

FRIXA CODE	MAKER	HYUNDAI	PART NUMBER		58305-47A00	
FLH11	REPRESENTATIVE MODEL	LIBERO	INTERCHANGEABLE	LIBERO		
	PO	SP	WVA	FMSI	HP	TRW
	REAR	SA100			HS0013	
				OUTSIDE RADIUS (mm)	109.5	
				WIDTH OF LINING (mm)	60.0	

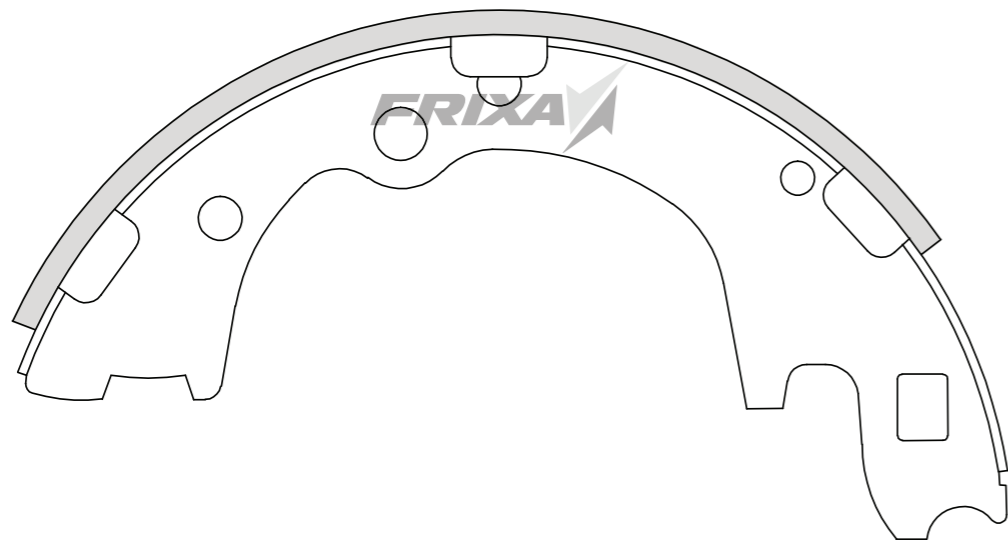

MAKER	HYUNDAI	PART NUMBER		58305-1CA00		FRIXA CODE
REPRESENTATIVE MODEL	CLICK	INTERCHANGEABLE	CLICK			FLH12
PO	SP	WVA	FMSI	HP	TRW	
REAR	SA133					
		OUTSIDE RADIUS (mm)	89.0			
		WIDTH OF LINING (mm)	30.0			

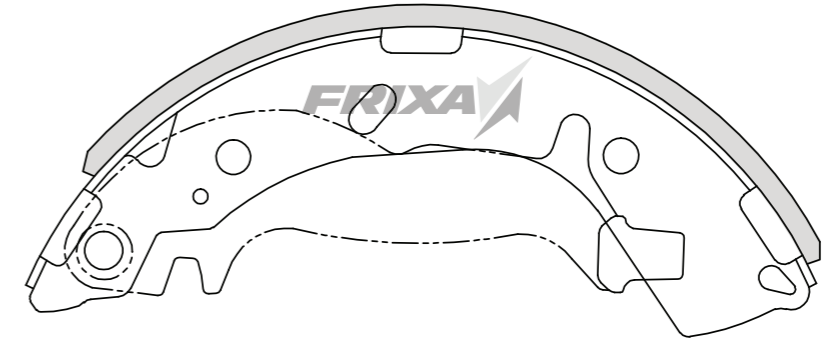

MAKER	HYUNDAI	PART NUMBER		58305-4AA20		FRIXA CODE
REPRESENTATIVE MODEL	STAREX NEW	INTERCHANGEABLE	STAREX NEW			FLH13
PO	SP	WVA	FMSI	HP	TRW	
REAR	SA130			HS0010		
		OUTSIDE RADIUS (mm)	146.9			
		WIDTH OF LINING (mm)	52.0			

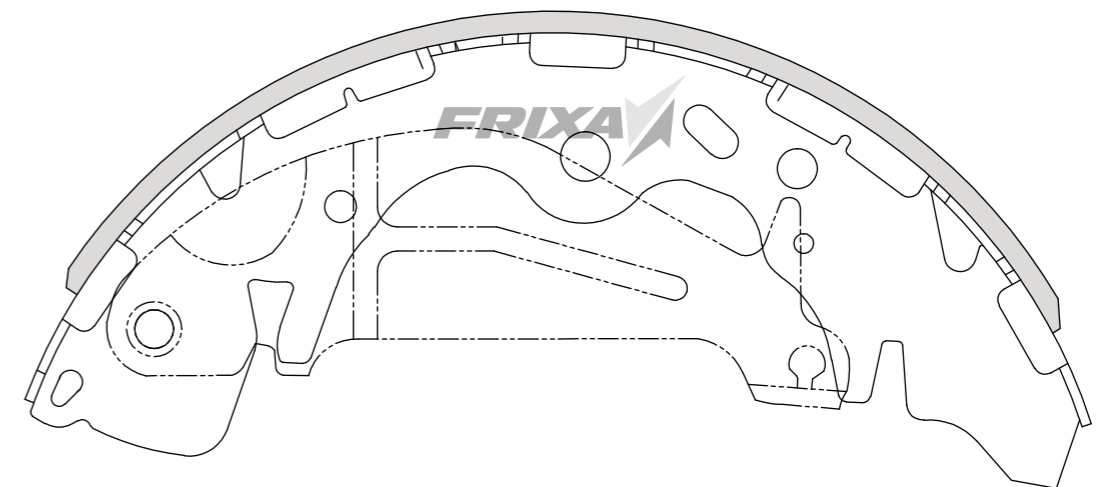

DISC BRAKE PAD

BRAKE SHOE ASSEMBLY

BRAKE LINING

DISC BRAKE PAD

BRAKE SHOE ASSEMBLY

BRAKE LINING

FRIXA CODE	MAKER	HYUNDAI	PART NUMBER		58305-4FA01	
FLH14	REPRESENTATIVE MODEL	PORTER II LOW DECK	INTERCHANGEABLE		PORTER II (LOW DECK) BONGO III (LOW DECK)	
	PO	SP	WVA	FMSI	HP	TRW
	REAR	SA135				
					OUTSIDE RADIUS (mm)	109.8
					WIDTH OF LINING (mm)	55.0

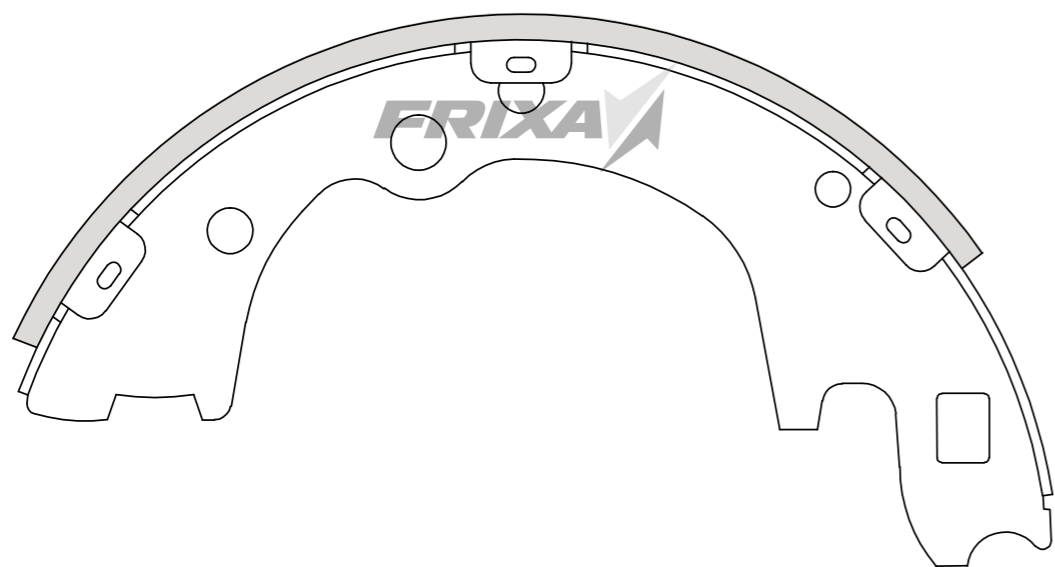

FRIXA CODE	MAKER	HYUNDAI	PART NUMBER		58305-4BA20	
FLH16	REPRESENTATIVE MODEL	PORTER (HIGH DECK)	INTERCHANGEABLE			
	PO	SP	WVA	FMSI	HP	TRW
	REAR	SA140				
					OUTSIDE RADIUS (mm)	127.1
					WIDTH OF LINING (mm)	50.0

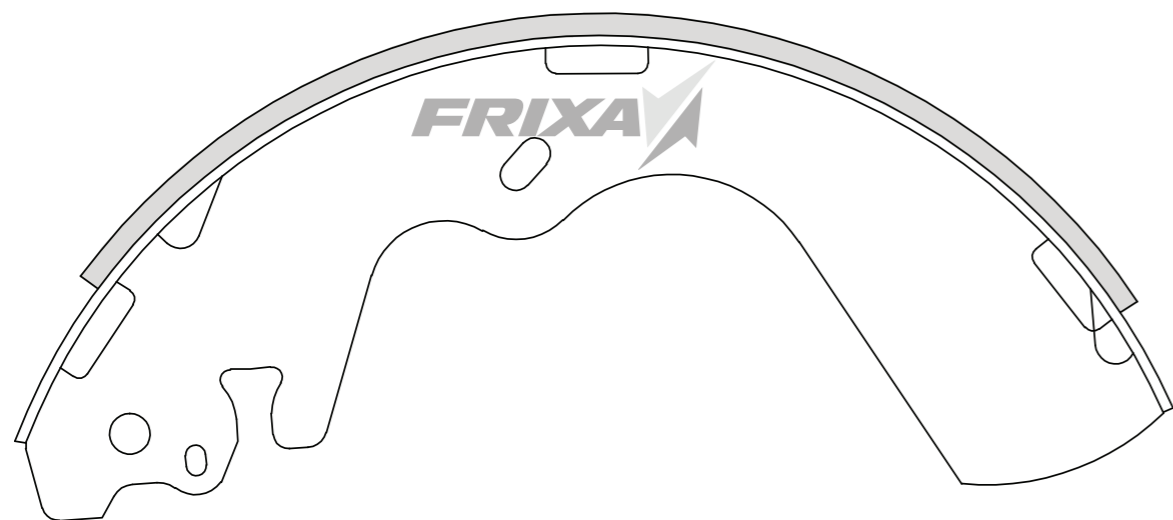

MAKER	KIA	PART NUMBER		KK150-26310		FRIXA CODE
REPRESENTATIVE MODEL	PRIDE	INTERCHANGEABLE		PRIDE/BETA		FLK01
PO	SP	WVA	FMSI	HP	TRW	
REAR	SA049			HS1001		
			OUTSIDE RADIUS (mm)	85.0		
			WIDTH OF LINING (mm)	25.0		

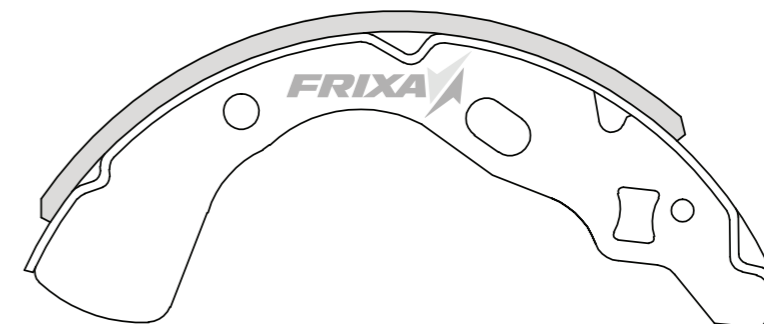

MAKER	KIA	PART NUMBER		OK917-2638Z		FRIXA CODE
REPRESENTATIVE MODEL	CONCORD	INTERCHANGEABLE		CONCORD, CAPITAL		FLK02
PO	SP	WVA	FMSI	HP	TRW	
REAR	SA052					
			OUTSIDE RADIUS (mm)	98.7		
			WIDTH OF LINING (mm)	25.0		

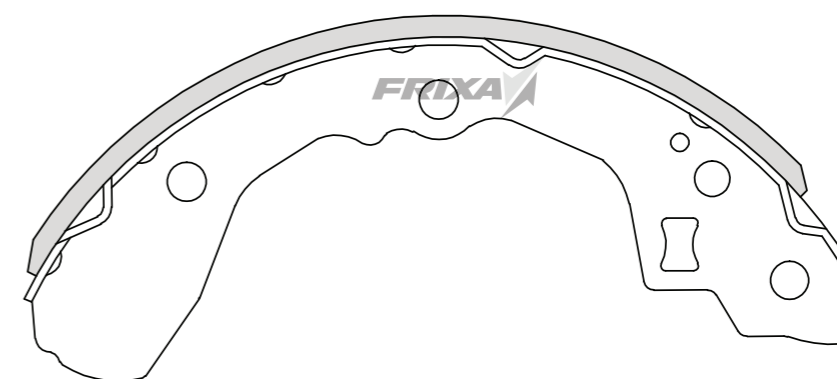

DISC BRAKE PAD

BRAKE SHOE ASSEMBLY

BRAKE LINING

DISC BRAKE PAD

BRAKE SHOE ASSEMBLY

BRAKE LINING

FRIXA CODE	MAKER	KIA		PART NUMBER			OK201-2638Z
FLKT02	REPRESENTATIVE MODEL	TOWNER	INTERCHANGEABLE	CONCORD TAXI CAPITAL TAXI, SEPHIA			
	PO	SP	WVA	FMSI	HP	TRW	
	REAR	SA051					
				OUTSIDE RADIUS (mm)			98.7
				WIDTH OF LINING (mm)			35.0

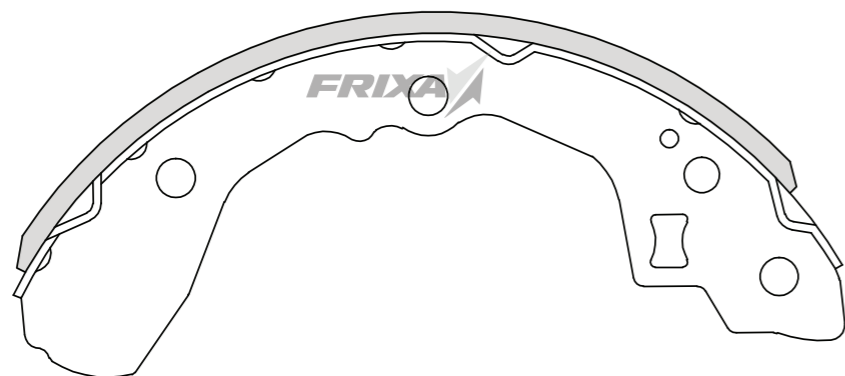

FRIXA CODE	MAKER	KIA		PART NUMBER			OK23N-2638Z
FLK03	REPRESENTATIVE MODEL	SEPHIA	INTERCHANGEABLE	SEPHIA(NEW)/II SPECTRA, SHUMA			
	PO	SP	WVA	FMSI	HP	TRW	
	REAR	SA053			HS1006		
				OUTSIDE RADIUS (mm)			98.9
				WIDTH OF LINING (mm)			35.0

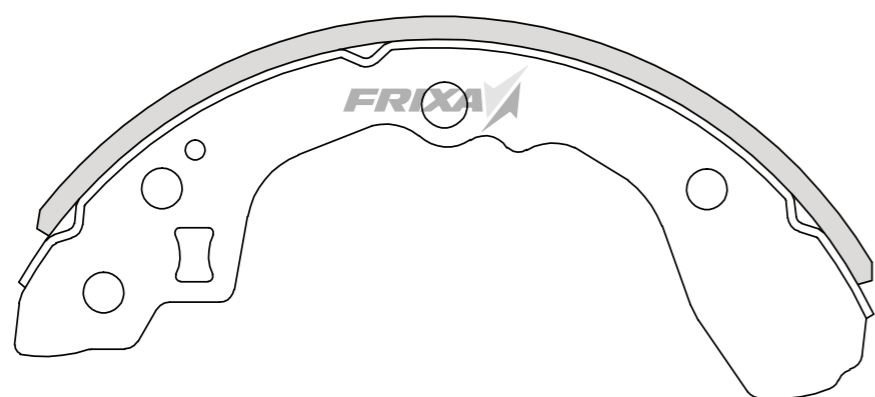

MAKER	KIA		PART NUMBER			OK2FA-2638Z	FRIXA CODE
REPRESENTATIVE MODEL	CARENS	INTERCHANGEABLE	CREDOS I / II, CARENS I / II			FLK04	
PO	SP	WVA	FMSI	HP	TRW		
REAR	SA079			HS1007			
			OUTSIDE RADIUS (mm)			114.0	
			WIDTH OF LINING (mm)			30.0	

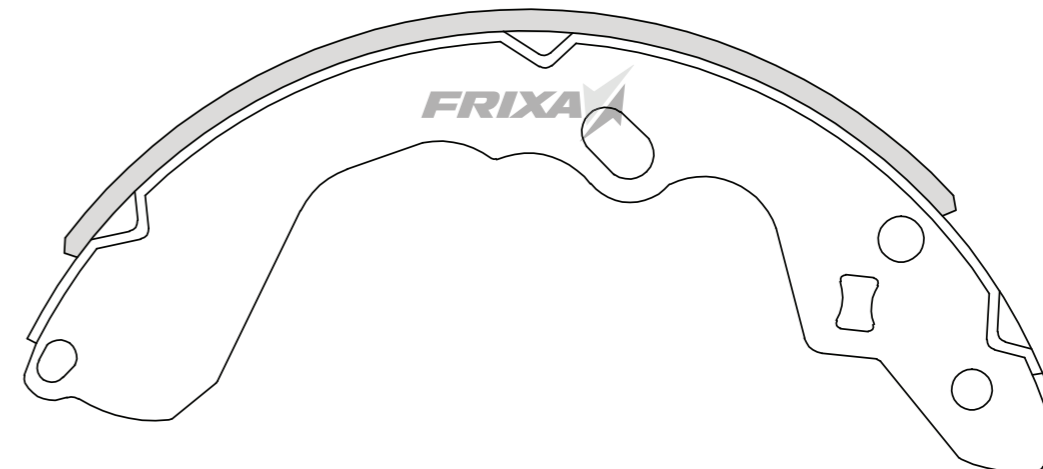

MAKER	KIA		PART NUMBER			OK011-2638Z	FRIXA CODE
REPRESENTATIVE MODEL	SPORTAGE	INTERCHANGEABLE	SPORTAGE			FLK07	
PO	SP	WVA	FMSI	HP	TRW		
REAR	SA070			HS1008			
			OUTSIDE RADIUS (mm)			124.5	
			WIDTH OF LINING (mm)			55.0	



DISC BRAKE PAD

BRAKE SHOE ASSEMBLY

BRAKE LINING

DISC BRAKE PAD

BRAKE SHOE ASSEMBLY

BRAKE LINING

FRIXA CODE	MAKER	KIA	PART NUMBER		OK70Y-2638Z	
FLK08	REPRESENTATIVE MODEL	BESTA	INTERCHANGEABLE		BESTA, TOPIC, BONGO NEW, PORTER II (HIGH DECK) BONGO III (HIGH DECK), BONGO III 1.4TON BONGO III COACH VAN (12 PEOPLE)	
	PO	SP	WVA	FMSI	HP	TRW
	REAR	SA044			HS1011	
					OUTSIDE RADIUS (mm)	128.0
					WIDTH OF LINING (mm)	50.0

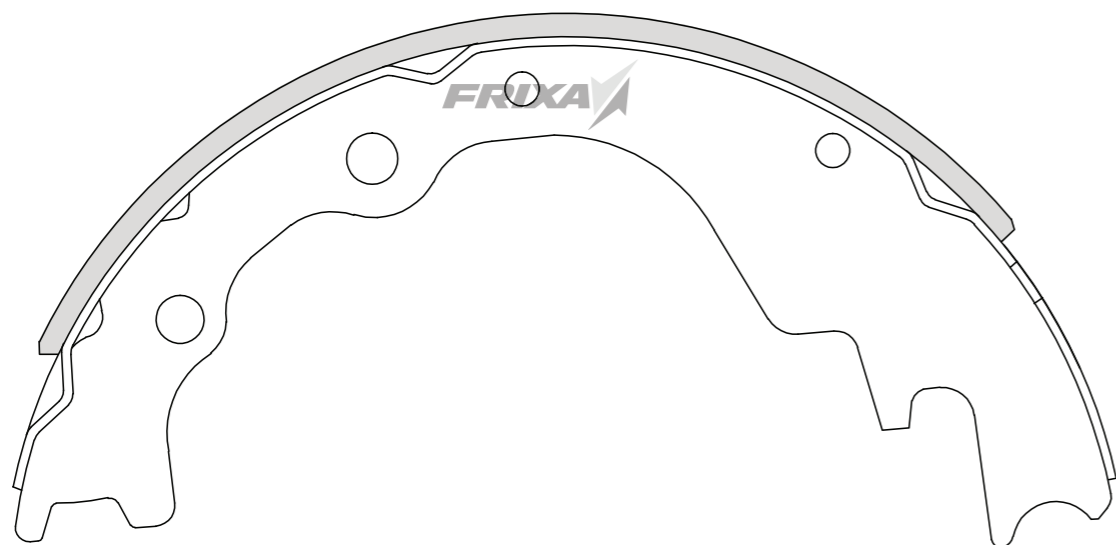

FRIXA CODE	MAKER	KIA	PART NUMBER		OK71F-3328Z	
FLK082	REPRESENTATIVE MODEL	WIDEBONGO	INTERCHANGEABLE		WIDEBONGO, FRONTIER 1.3TON(NEW) FRONTIER 1.4TON(NEW)	
	PO	SP	WVA	FMSI	HP	TRW
	REAR	SA045			HS1010	
					OUTSIDE RADIUS (mm)	109.3
					WIDTH OF LINING (mm)	55.0

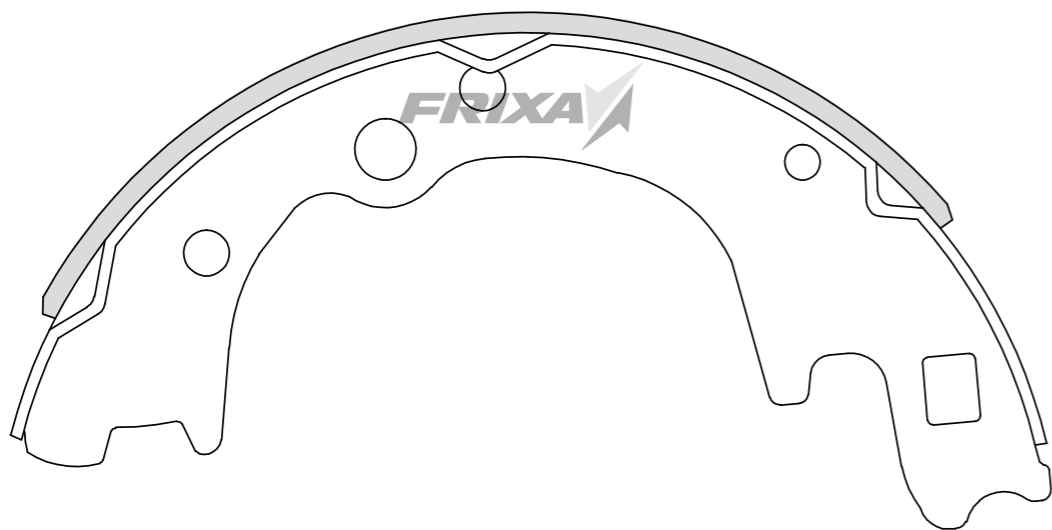

MAKER	KIA	PART NUMBER		OK72A-2638Z		FRIXA CODE
REPRESENTATIVE MODEL	PREGIO	INTERCHANGEABLE		PREGIO		FLK10
PO	SP	WVA	FMSI	HP	TRW	
REAR	SA044			HS1011		
					OUTSIDE RADIUS (mm)	126.8
					WIDTH OF LINING (mm)	50.0

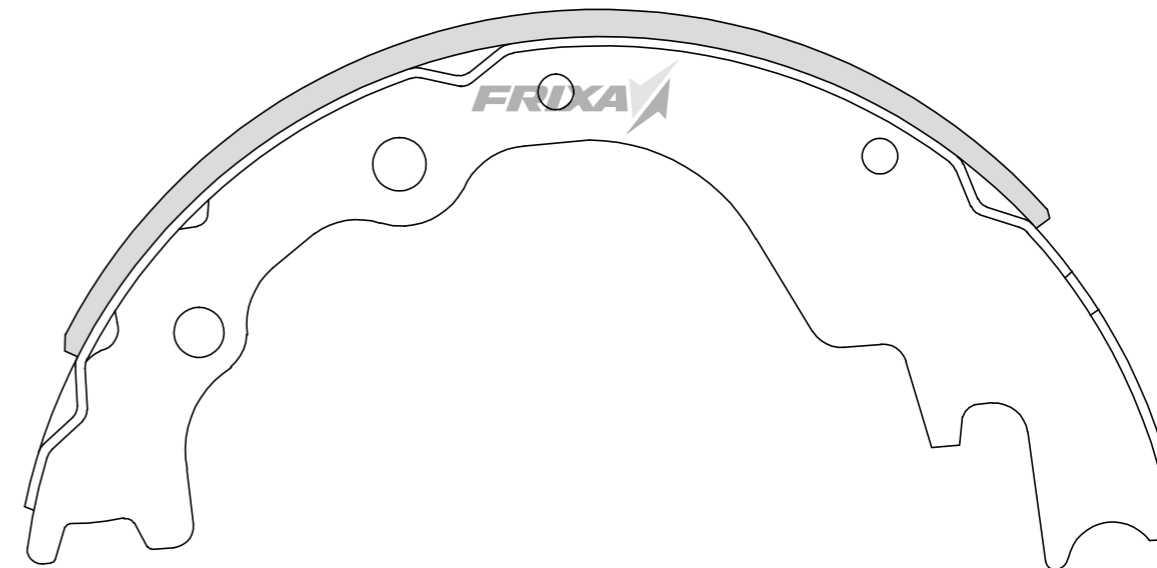

MAKER	KIA	PART NUMBER		OK79A-2638Z		FRIXA CODE
REPRESENTATIVE MODEL	PREGIOGRAND	INTERCHANGEABLE		NEWPREGIO BONGO III COACH VNA(15PEOPLE)		FLK10N
PO	SP	WVA	FMSI	HP	TRW	
REAR	SA127			HS1013		
					OUTSIDE RADIUS (mm)	128.0
					WIDTH OF LINING (mm)	59.5

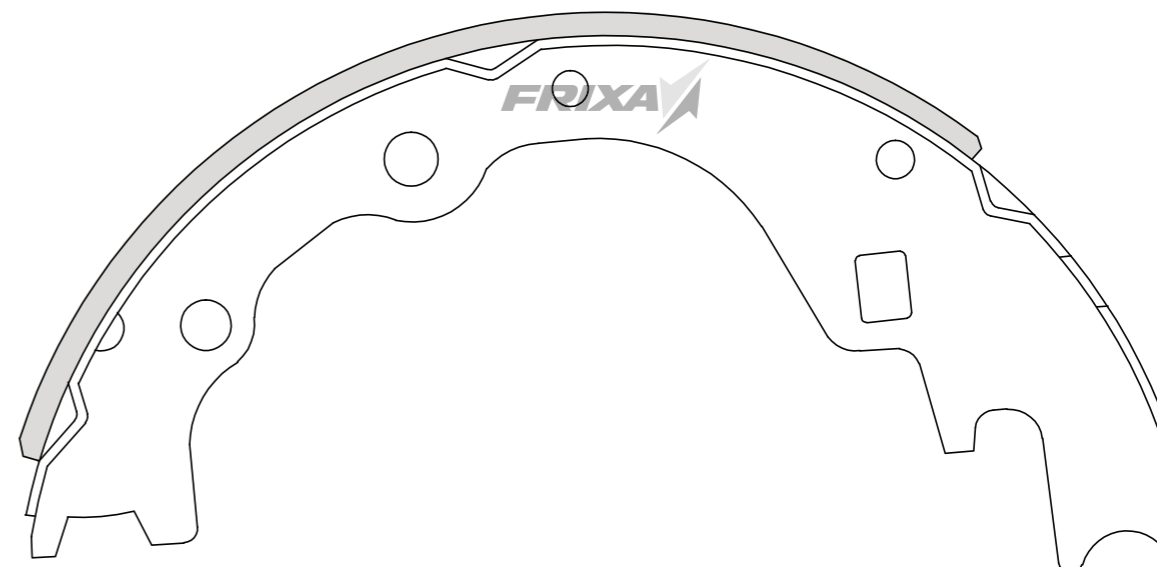

DISC BRAKE PAD

DISC BRAKE PAD

DISC BRAKE PAD

DISC BRAKE PAD

DISC BRAKE PAD

DISC BRAKE PAD

FRIXA CODE	MAKER	KIA	PART NUMBER			0K552-2638Z
FLK13	REPRESENTATIVE MODEL	CARNIVAL	INTERCHANGEABLE		CARNIVAL, TRAGET XG	
	PO	SP	WVA	FMSI	HP	TRW
	REAR	SA112			HS1012	
					OUTSIDE RADIUS (mm)	125.0
					WIDTH OF LINING (mm)	55.0

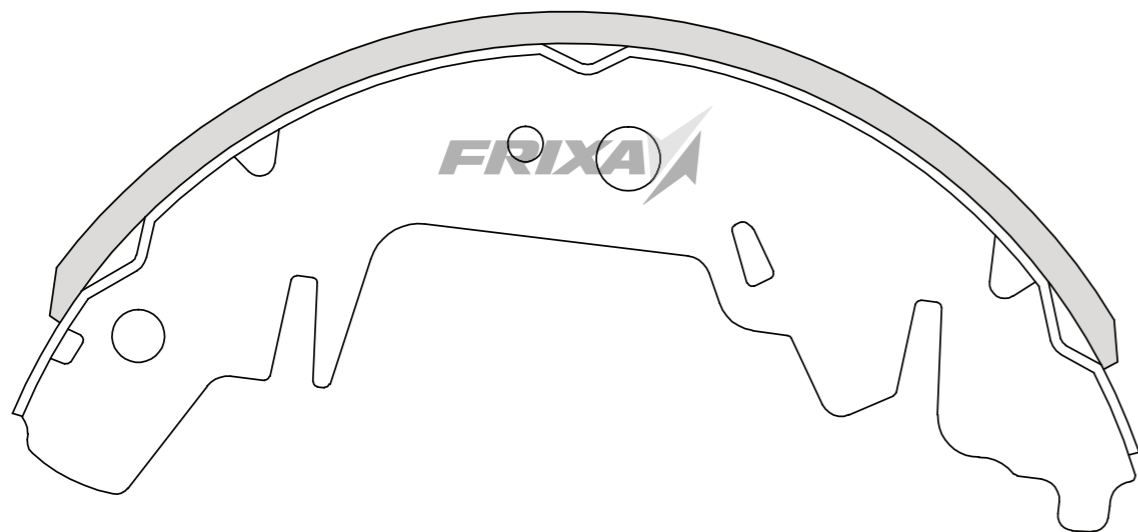

FRIXA CODE	MAKER	KIA	PART NUMBER			0K56A-2638Z
FLK13N	REPRESENTATIVE MODEL	CARNIVAL(NEW)	INTERCHANGEABLE		CARNIVAL II, TRAGETXG	
	PO	SP	WVA	FMSI	HP	TRW
	REAR	SA020			HS1014	
					OUTSIDE RADIUS (mm)	125.9
					WIDTH OF LINING (mm)	55.0

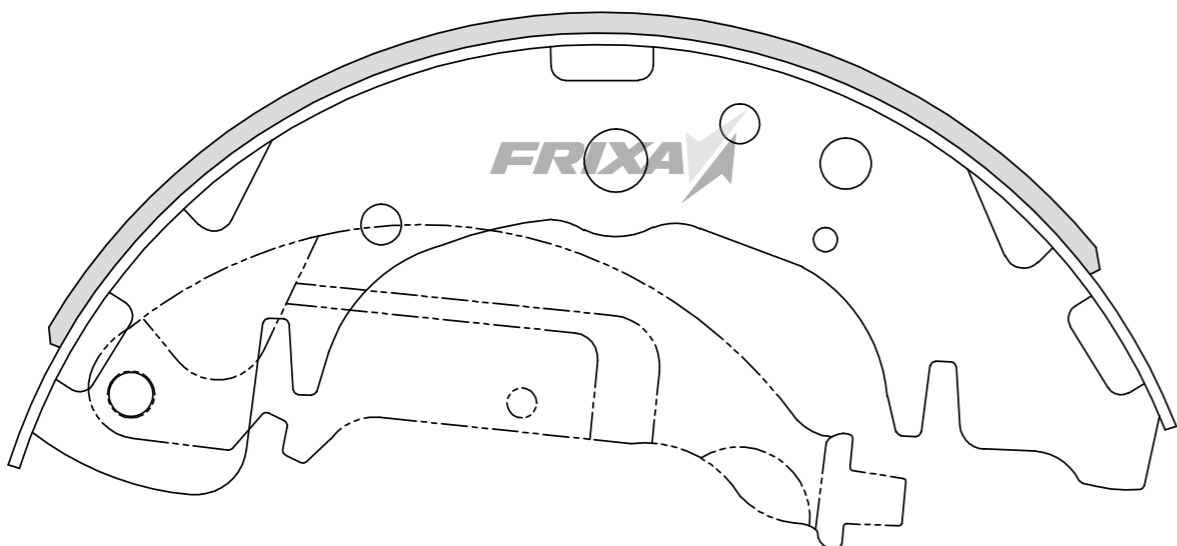

MAKER	KIA	PART NUMBER			01823-2638Z	FRIXA CODE
REPRESENTATIVE MODEL	CERES	INTERCHANGEABLE		CERES, BONGO(OLD)		FLK14
PO	SP	WVA	FMSI	HP	TRW	
REAR	SA015					
					OUTSIDE RADIUS (mm)	128.5
					WIDTH OF LINING (mm)	45.0

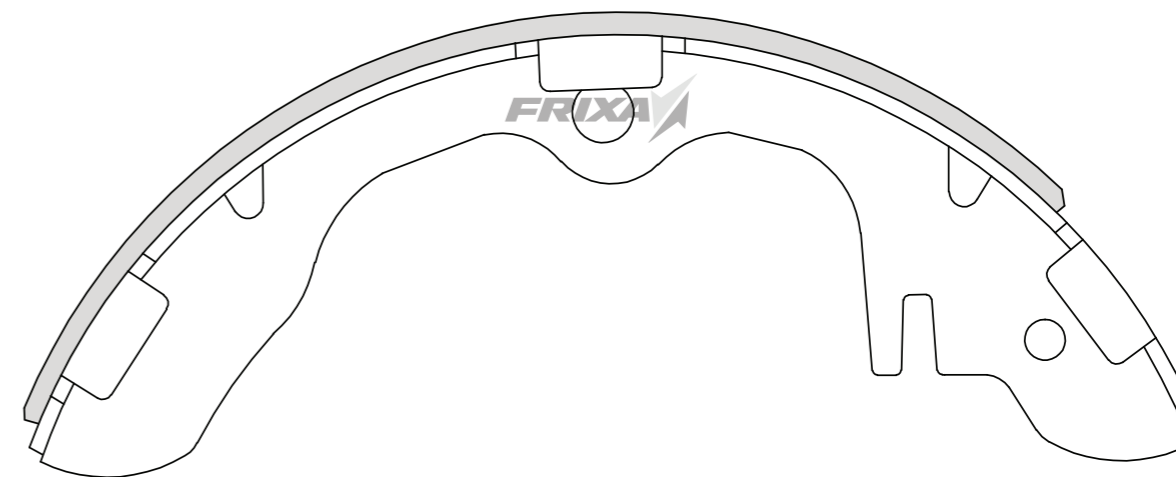

MAKER	KIA	PART NUMBER			0K68A-3328Z	FRIXA CODE
REPRESENTATIVE MODEL	CERES(NEW)	INTERCHANGEABLE		CERES(NEW)		FLK14N
PO	SP	WVA	FMSI	HP	TRW	
REAR	SA019					
					OUTSIDE RADIUS (mm)	128.5
					WIDTH OF LINING (mm)	53.0

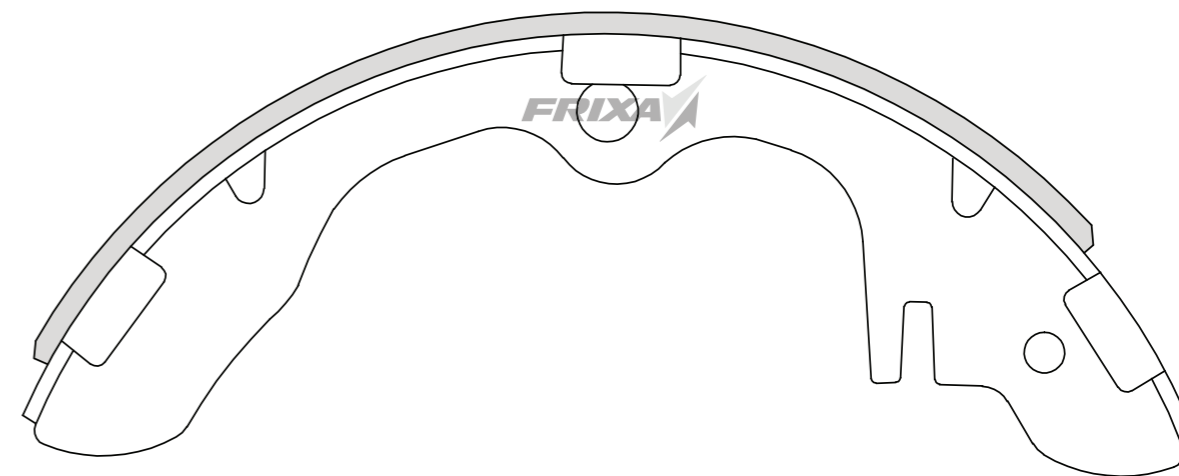

DISC BRAKE PAD

BRAKE SHOE ASSEMBLY

BRAKE LINING

DISC BRAKE PAD

BRAKE SHOE ASSEMBLY

BRAKE LINING

FRIXA CODE	MAKER	KIA	PART NUMBER		OK30A-2628Z	
FLK15	REPRESENTATIVE MODEL	RIO	INTERCHANGEABLE		RIO	
	PO	SP	WVA	FMSI	HP	TRW
	REAR	SA137			HS1002	

OUTSIDE RADIUS (mm)	99.5
WIDTH OF LINING (mm)	25.0



FRIXA CODE	MAKER	KIA	PART NUMBER		OK30B-2628Z	
FLK15N	REPRESENTATIVE MODEL	RIOSF	INTERCHANGEABLE		RIOSF	
	PO	SP	WVA	FMSI	HP	TRW
	REAR	SA134			HS1003	

OUTSIDE RADIUS (mm)	99.9
WIDTH OF LINING (mm)	30.0



MAKER	KIA	PART NUMBER		OK045-2638Z		FRIXA CODE
REPRESENTATIVE MODEL	ROCSTA R2	INTERCHANGEABLE		ROCSTA R2 SPORTAGE(NEW), RETONA		FLK16
PO	SP	WVA	FMSI	HP	TRW	
REAR	SA018					

OUTSIDE RADIUS (mm)	129.2
WIDTH OF LINING (mm)	45.0

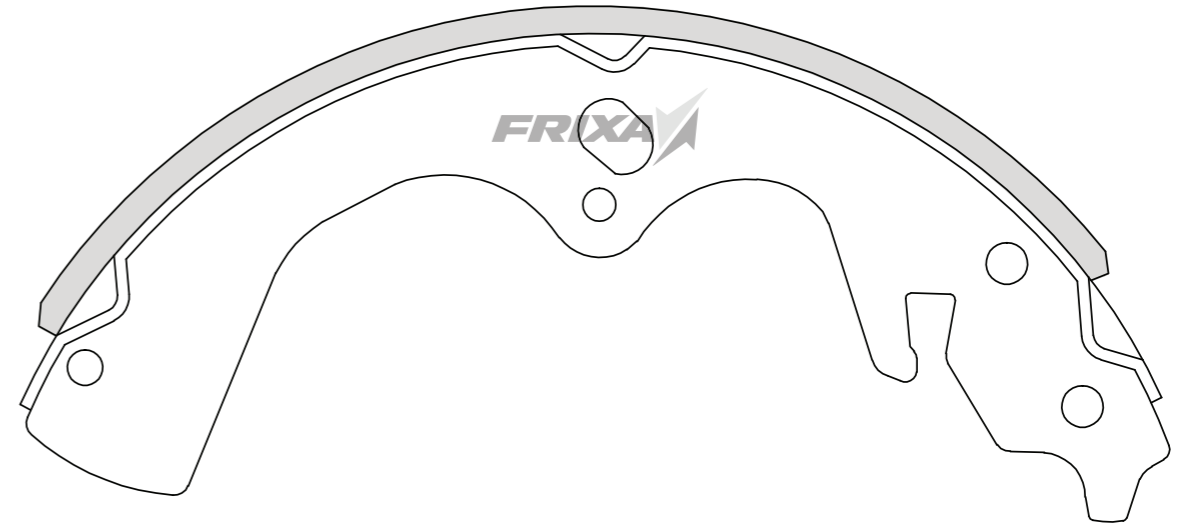

MAKER	KIA	PART NUMBER		K611-2638Z		FRIXA CODE
REPRESENTATIVE MODEL	FRONTIER 1.3	INTERCHANGEABLE		FRONTIER 1.3TON(OLD) FRONTIER 1.4TON(OLD)		FLK17
PO	SP	WVA	FMSI	HP	TRW	
REAR						

OUTSIDE RADIUS (mm)	101.2
WIDTH OF LINING (mm)	45.0

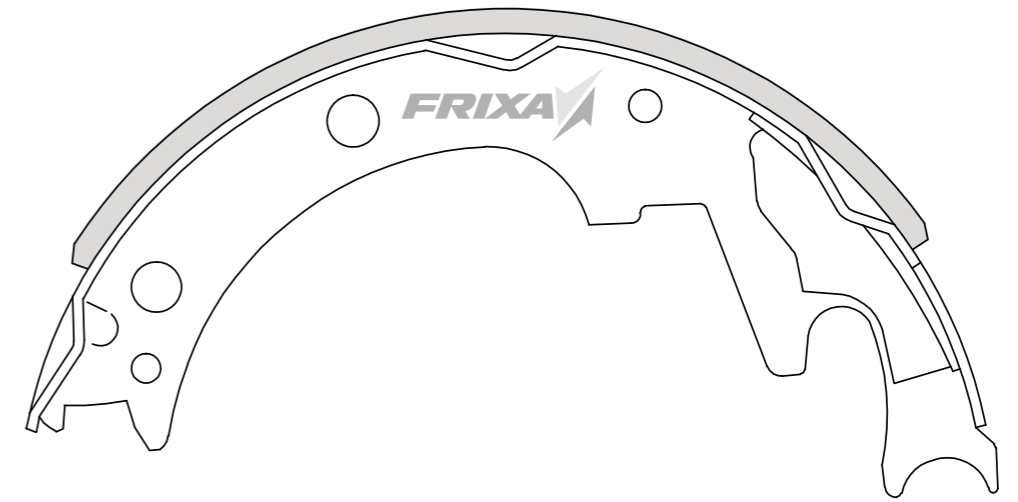

DISC BRAKE PAD

BRAKE SHOE ASSEMBLY

BRAKE LINING

DISC BRAKE PAD

BRAKE SHOE ASSEMBLY

BRAKE LINING

FRIXA CODE	MAKER	KIA	PART NUMBER	58305-1GA00		
FLK18	REPRESENTATIVE MODEL	PRIDE(NEW)	INTERCHANGEABLE	PRIDE 05MY, VERNA 05MY		
	PO	SP	WVA	FMSI	HP	TRW
	REAR	SA153				

OUTSIDE RADIUS (mm)	101.2
WIDTH OF LINING (mm)	30.0

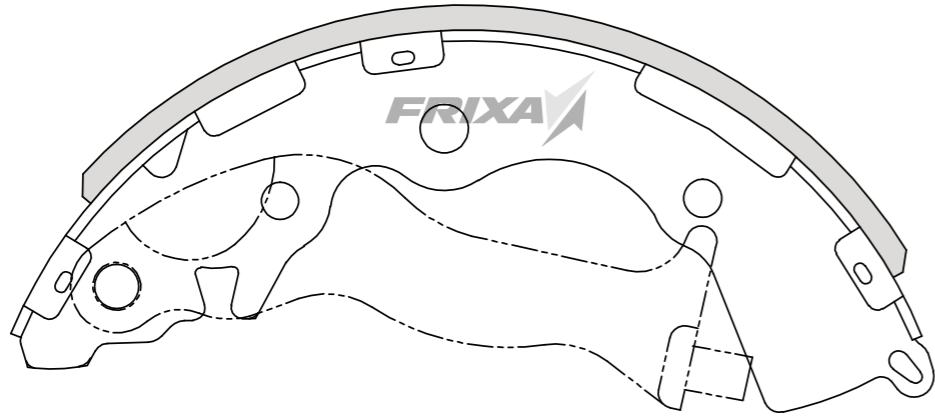

FRIXA CODE	MAKER	KIA	PART NUMBER	58350-07A00		
FLK19	REPRESENTATIVE MODEL	MORNING	INTERCHANGEABLE	MORNING		
	PO	SP	WVA	FMSI	HP	TRW
	REAR	SA154				

OUTSIDE RADIUS (mm)	90.0
WIDTH OF LINING (mm)	30.0

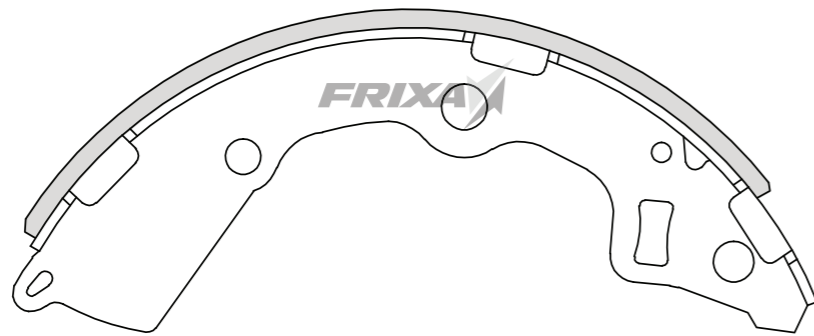

MAKER	CHEVROLET (GM-DAEWOO)	PART NUMBER	53200-70800-000			FRIXA CODE
REPRESENTATIVE MODEL	TICO	INTERCHANGEABLE	TICO, MATIZ			FLD01
PO	SP	WVA	FMSI	HP	TRW	
REAR	SA050			HS2001	GS8645	

OUTSIDE RADIUS (mm)	89.6
WIDTH OF LINING (mm)	30.0

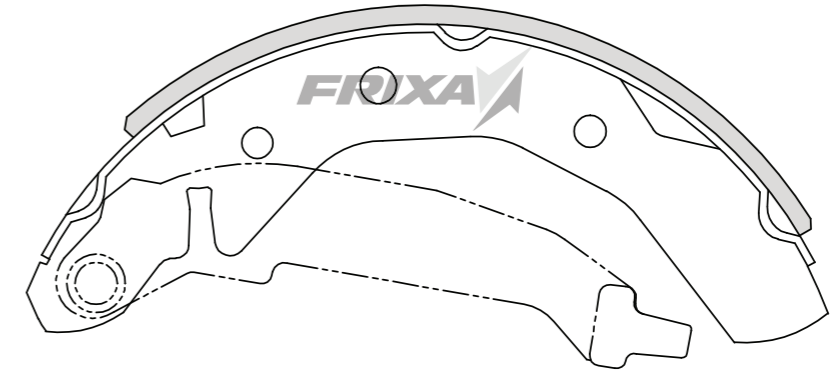

MAKER	CHEVROLET (GM-DAEWOO)	PART NUMBER	S4520001			FRIXA CODE
REPRESENTATIVE MODEL	PRINCE	INTERCHANGEABLE	PRINCE, ROYAL PRINCE BROUGHAM			FLD02
PO	SP	WVA	FMSI	HP	TRW	
REAR	SA010			HS2006		

OUTSIDE RADIUS (mm)	114.1
WIDTH OF LINING (mm)	50.0

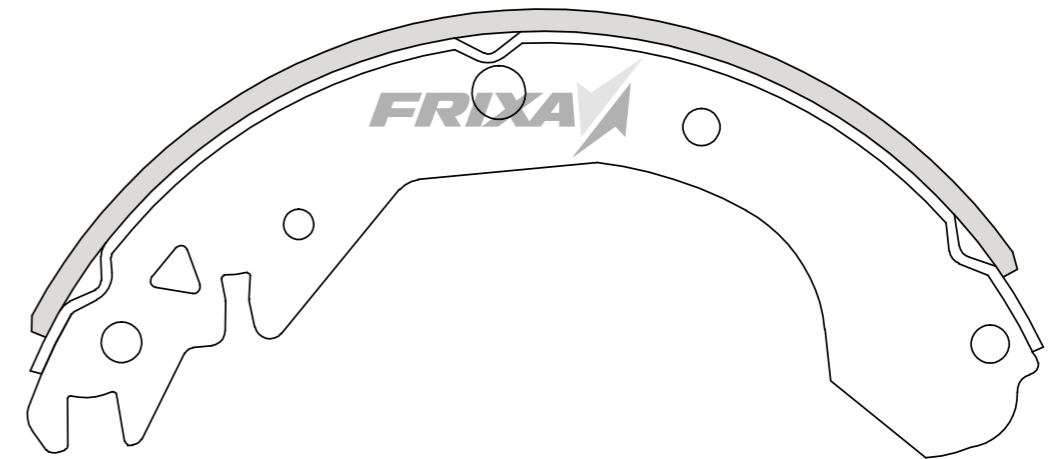

DISC BRAKE PAD

BRAKE SHOE ASSEMBLY

BRAKE LINING

DISC BRAKE PAD

BRAKE SHOE ASSEMBLY

BRAKE LINING

FRIXA CODE	MAKER	CHEVROLET (GM-DAEWOO)	PART NUMBER	90272780		
FLD03	REPRESENTATIVE MODEL	LEMANS	INTERCHANGEABLE	LEMANS, ESPERO(OLD)		
	PO	SP	WVA	FMSI	HP	TRW
	REAR	SA055-OLD			HS2004	
				OUTSIDE RADIUS (mm)	99.7	
				WIDTH OF LINING (mm)	45.0	

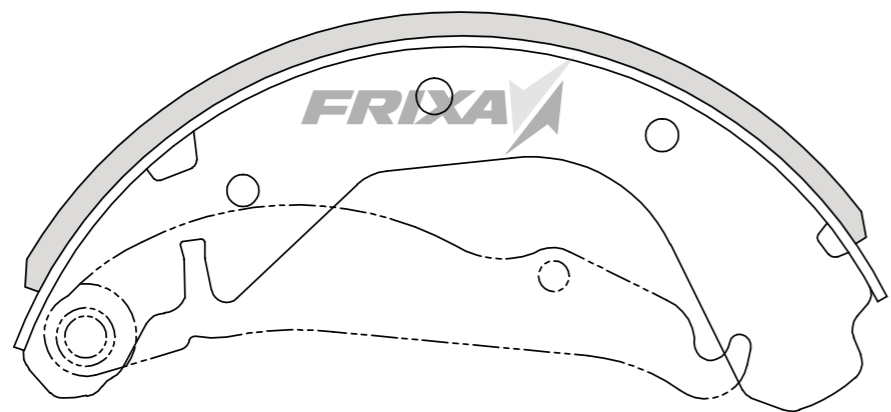

FRIXA CODE	MAKER	CHEVROLET (GM-DAEWOO)	PART NUMBER	96226110		
FLD04	REPRESENTATIVE MODEL	ESPERO(NEW)	INTERCHANGEABLE	ESPERO(NEW), CIELO, NEXIA LANOS, NUBIRA I / II		
	PO	SP	WVA	FMSI	HP	TRW
	REAR	SA055-NEW			HS2005	
				OUTSIDE RADIUS (mm)	99.3	
				WIDTH OF LINING (mm)	45.0	

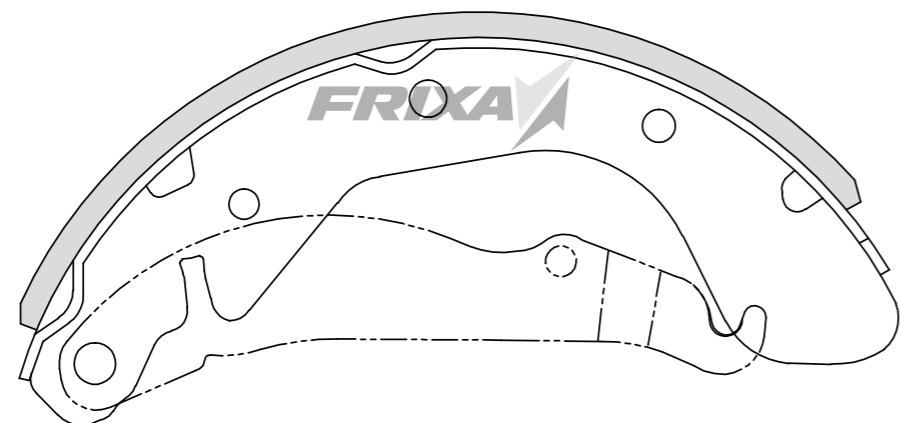

MAKER	CHEVROLET (GM-DAEWOO)	PART NUMBER	53200-85800			FRIXA CODE
REPRESENTATIVE MODEL	DAMAS	INTERCHANGEABLE	DAMAS, DAMAS II, LABO			FLD07
PO	SP	WVA	FMSI	HP	TRW	
REAR	SA059			HS2003		
		OUTSIDE RADIUS (mm)	109.6			
		WIDTH OF LINING (mm)	39.0			

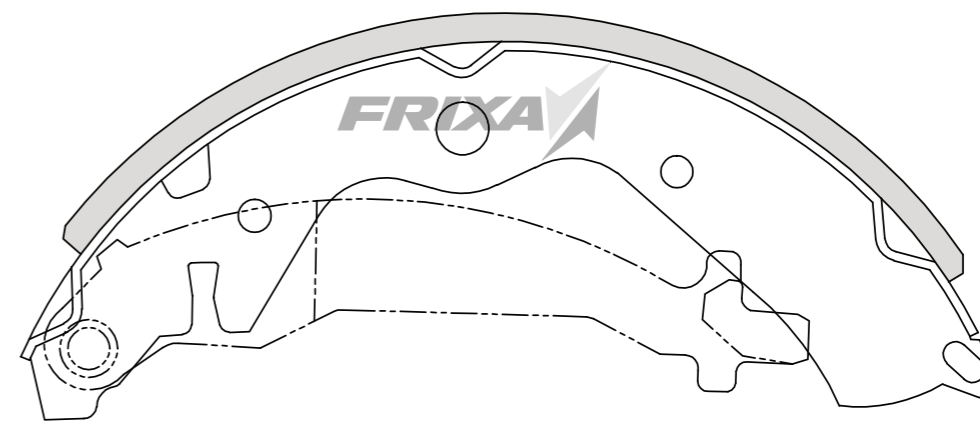

MAKER	CHEVROLET (GM-DAEWOO)	PART NUMBER	96245180			FRIXA CODE
REPRESENTATIVE MODEL	LEGANZA	INTERCHANGEABLE	LEGANZA, NUBIRA DOHC			FLD08
PO	SP	WVA	FMSI	HP	TRW	
REAR	SA102			HS2007		
		OUTSIDE RADIUS (mm)	114.1			
		WIDTH OF LINING (mm)	50.0			

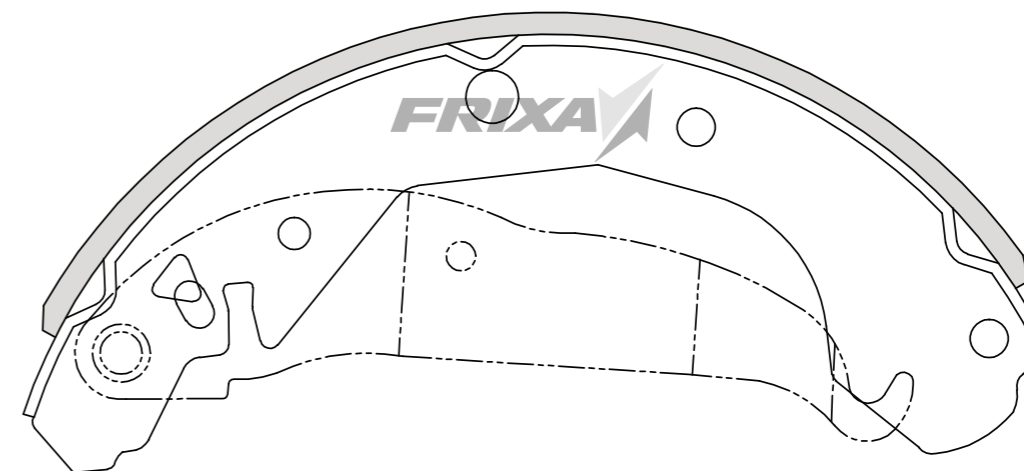

DISC BRAKE PAD

DISC BRAKE PAD

DISC BRAKE PAD

DISC BRAKE PAD

DISC BRAKE PAD

DISC BRAKE PAD

FRIXA CODE	MAKER	CHEVROLET (GM-DAEWOO)	PART NUMBER	96349066		
FLD09	REPRESENTATIVE MODEL	REZZO	INTERCHANGEABLE	REZZO		
	PO	SP	WVA	FMSI	HP	TRW
	REAR	SA103			HS2008	
				OUTSIDE RADIUS (mm)	114.7	
				WIDTH OF LINING (mm)	50.0	

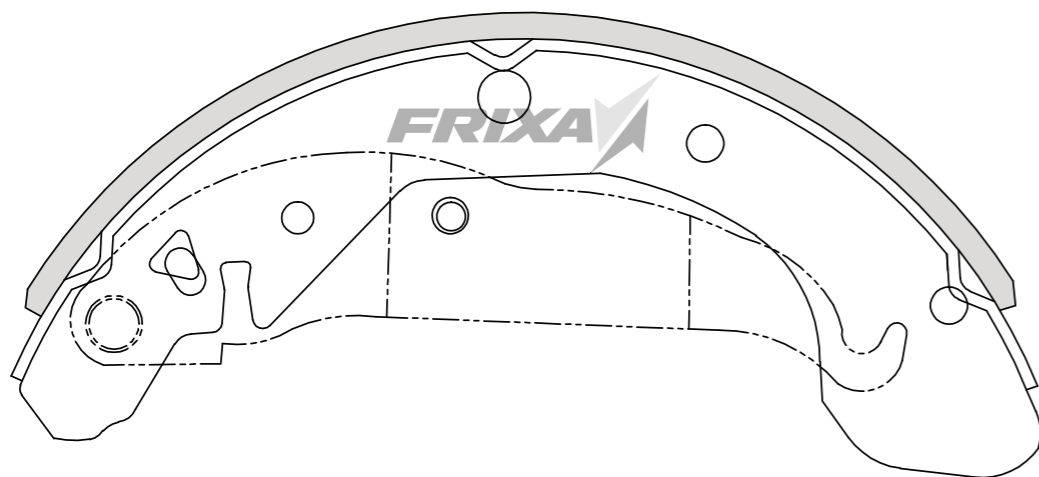

FRIXA CODE	MAKER	CHEVROLET (GM-DAEWOO)	PART NUMBER	83740251		
FLD10	REPRESENTATIVE MODEL	KALOS	INTERCHANGEABLE	KALOS		
	PO	SP	WVA	FMSI	HP	TRW
	REAR	SA129			HS2009	
				OUTSIDE RADIUS (mm)	99.6	
				WIDTH OF LINING (mm)	35.0	

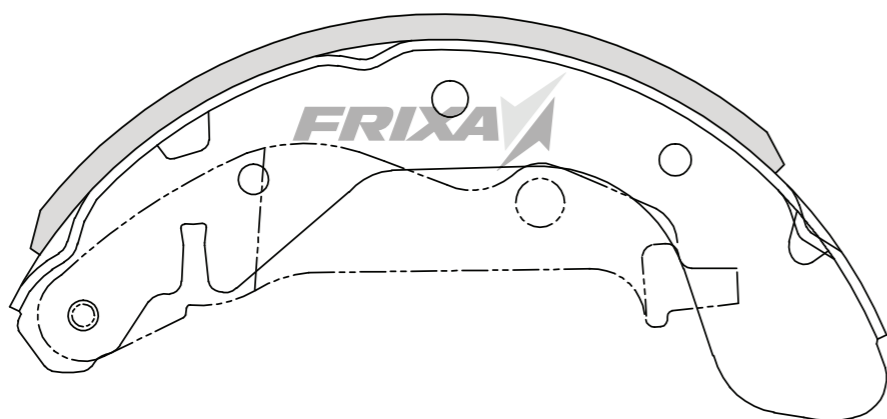

MAKER	CHEVROLET (GM-DAEWOO)	PART NUMBER	96446745			FRIXA CODE
REPRESENTATIVE MODEL	MAGNUS	INTERCHANGEABLE	MAGNUS			FLD11
PO	SP	WVA	FMSI	HP	TRW	
REAR	SA119					
		OUTSIDE RADIUS (mm)	113.7			
		WIDTH OF LINING (mm)	40.0			

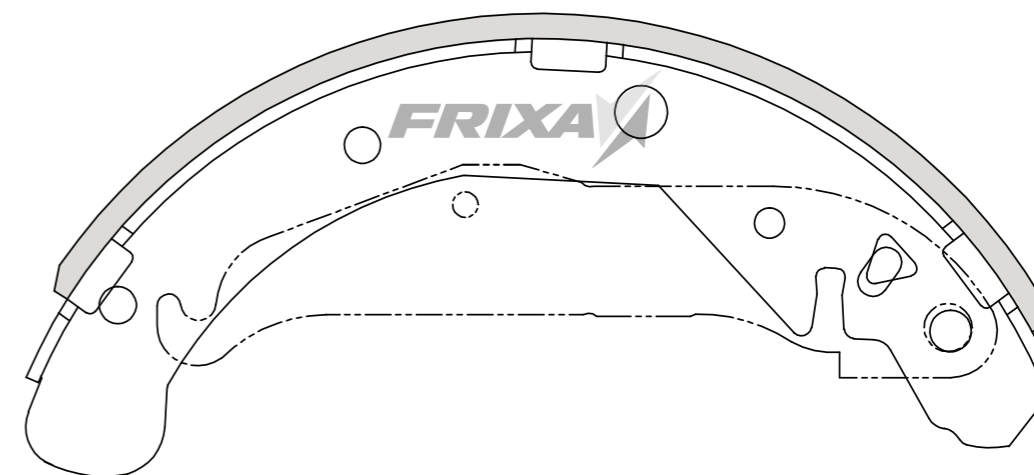

MAKER	SAMSUNG	PART NUMBER	48430-31010K0			FRIXA CODE
REPRESENTATIVE MODEL	SM-3	INTERCHANGEABLE	SM-3			FLS01
PO	SP	WVA	FMSI	HP	TRW	
REAR	SA131					
		OUTSIDE RADIUS (mm)	100.7			
		WIDTH OF LINING (mm)	35.0			

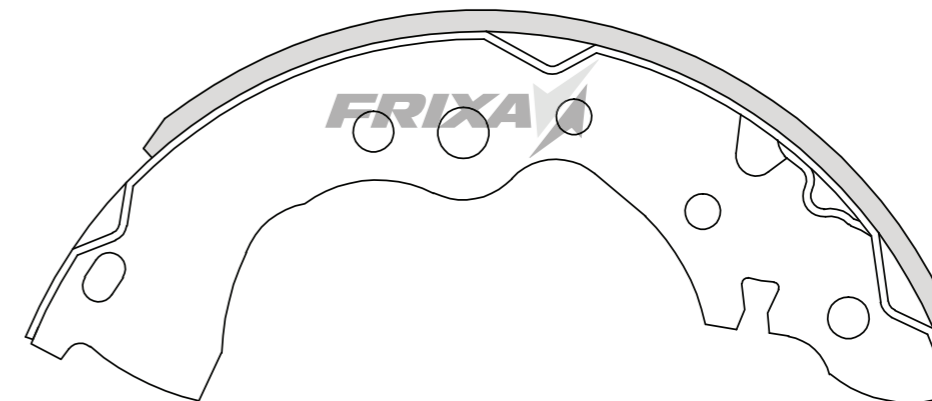

DISC BRAKE PAD

BRAKE SHOE ASSEMBLY

BRAKE LINING

DISC BRAKE PAD

BRAKE SHOE ASSEMBLY

BRAKE LINING

FRIXA CODE	MAKER	RENAULT / PEUGEOT	PART NUMBER	77 01 201 758		
FLE01	REPRESENTATIVE MODEL	CLIO / LOGAN 106 / 206 / 306	INTERCHANGEABLE	BB0, CB0(98.03~01.05) L90		
	PO	SP	WVA	FMSI	HP	TRW
	REAR					GS8534
				OUTSIDE RADIUS (mm)		
				WIDTH OF LINING (mm)		

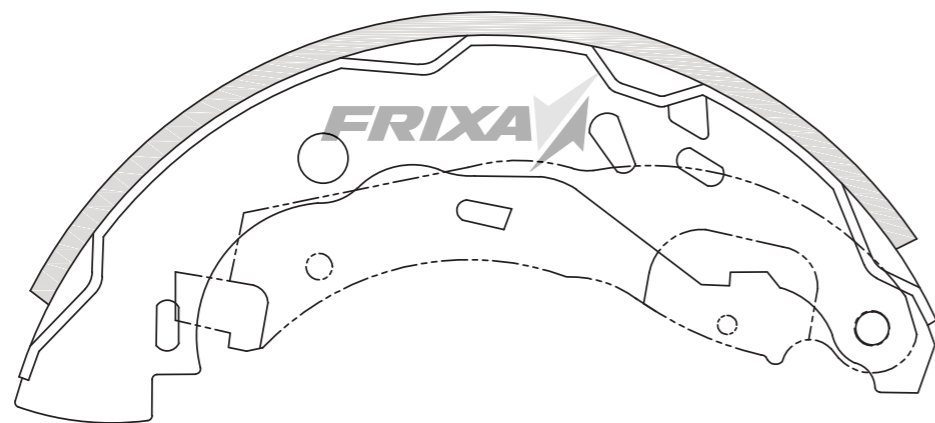

FRIXA CODE	MAKER		PART NUMBER			
	REPRESENTATIVE MODEL		INTERCHANGEABLE			
	PO	SP	WVA	FMSI	HP	TRW
				OUTSIDE RADIUS (mm)		
				WIDTH OF LINING (mm)		

MAKER	HYUNDAI	PART NUMBER				FRIXA CODE
REPRESENTATIVE MODEL	2.5TON	INTERCHANGEABLE				FLTH01
PO	SP	WVA	FMSI	HP	TRW	
REAR						
		OUTSIDE RADIUS (mm)		161.7		
		WIDTH OF LINING (mm)		75.0		

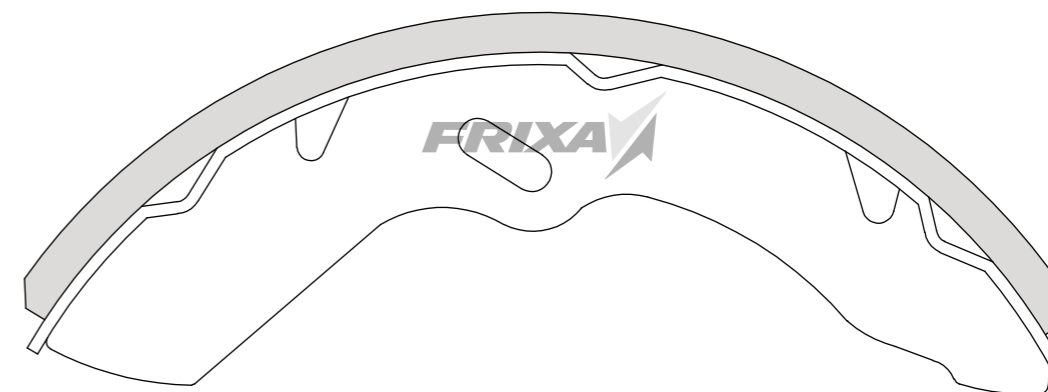

MAKER	HYUNDAI	PART NUMBER				FRIXA CODE
REPRESENTATIVE MODEL	3.5TON OLD	INTERCHANGEABLE				FLTH02
PO	SP	WVA	FMSI	HP	TRW	
REAR	SA011					
		OUTSIDE RADIUS (mm)		160.2		
		WIDTH OF LINING (mm)		85.0		

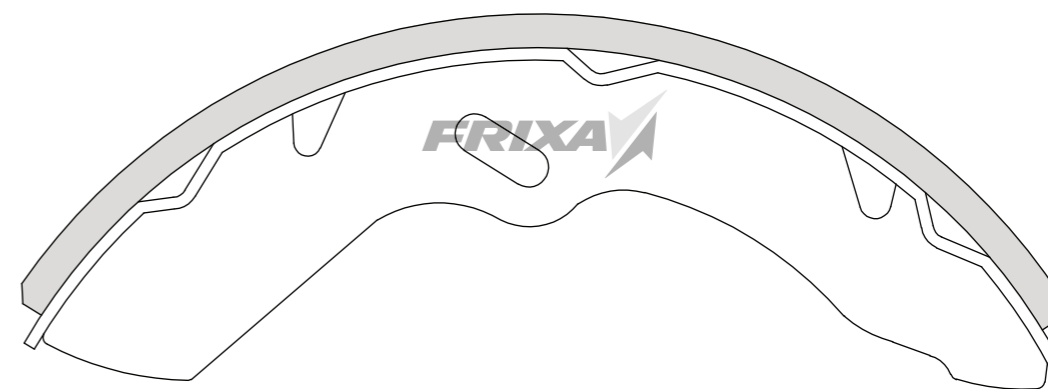

DISC BRAKE PAD

BRAKE SHOE ASSEMBLY

BRAKE LINING

DISC BRAKE PAD

BRAKE SHOE ASSEMBLY

BRAKE LINING

FRIXA CODE	MAKER	HYUNDAI	PART NUMBER			
FLTH03	REPRESENTATIVE MODEL	3.5TON NEW(V/UP)	INTERCHANGEABLE			
	PO	SP	WVA	FMSI	HP	TRW
	REAR	SA014				
					OUTSIDE RADIUS (mm)	159.5
					WIDTH OF LINING (mm)	85.0

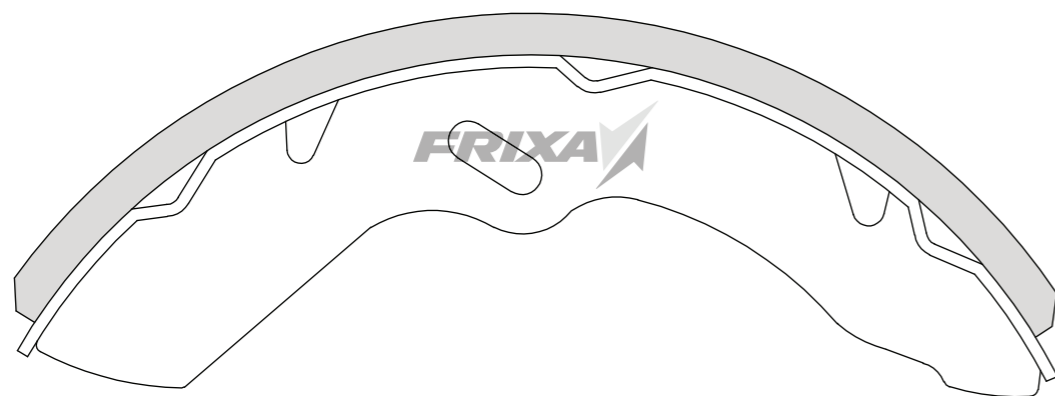

FRIXA CODE	MAKER	HYUNDAI	PART NUMBER			
FLTH09	REPRESENTATIVE MODEL	2.5TON LOW DECK PRI 2.5TON LOW DECK SEC	INTERCHANGEABLE			
	PO	SP	WVA	FMSI	HP	TRW
	REAR					
					OUTSIDE RADIUS (mm)	150.1
					WIDTH OF LINING (mm)	75.0

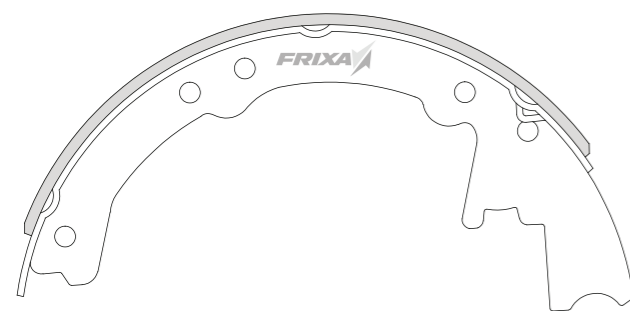

2.5TON LOW DECK PRI

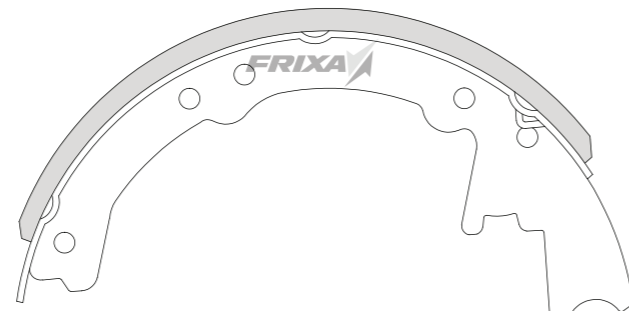

2.5TON LOW DECK SEC

MAKER	HYUNDAI	PART NUMBER				FRIXA CODE
REPRESENTATIVE MODEL	E-MIGHTY 3.5TON	INTERCHANGEABLE				FLTH10
PO	SP	WVA	FMSI	HP	TRW	
REAR	SA151					
					OUTSIDE RADIUS (mm)	159.0
					WIDTH OF LINING (mm)	110.0

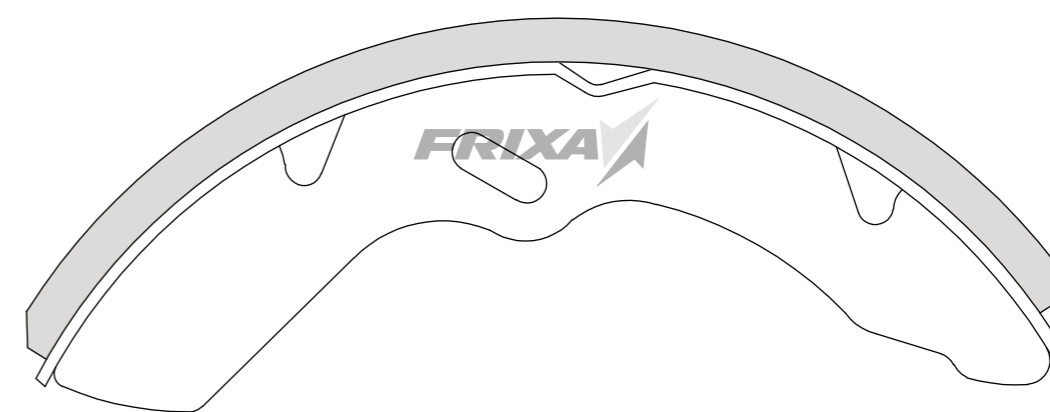

MAKER	KIA	PART NUMBER				FRIXA CODE
REPRESENTATIVE MODEL	2.5TON JUMBO	INTERCHANGEABLE				FLTK01
PO	SP	WVA	FMSI	HP	TRW	
FRONT						
					OUTSIDE RADIUS (mm)	159.7
					WIDTH OF LINING (mm)	75.0



DISC BRAKE PAD

BRAKE SHOE ASSEMBLY

BRAKE LINING

DISC BRAKE PAD

BRAKE SHOE ASSEMBLY

BRAKE LINING

FRIXA CODE	MAKER	KIA	PART NUMBER			
FLTK02	REPRESENTATIVE MODEL	2.5TON(NEW) POWER COMBI	INTERCHANGEABLE			
	PO	SP	WVA	FMSI	HP	TRW
	REAR					
					OUTSIDE RADIUS (mm)	157.5
					WIDTH OF LINING (mm)	95.0



FRIXA CODE	MAKER	KIA	PART NUMBER			
FLTK03	REPRESENTATIVE MODEL	2.5TON(NEW) POWER COMBI	INTERCHANGEABLE			
	PO	SP	WVA	FMSI	HP	TRW
	REAR					
					OUTSIDE RADIUS (mm)	160.5
					WIDTH OF LINING (mm)	95.0



FRIXA BRAKE SYSTEM

BRAKE LINING

BLOCK LINING	P. 174 ~
FOR HEAVY DUTY TRUCKS AND BUSES	
LINING - Only	P.176 ~
FOR LIGHT TRUCK	

FRIXA BRAKE SYSTEM
We guarantee accurate and safe braking

BRAKE LINING

DISC BRAKE PAD

BRAKE SHOE ASSEMBLY

BRAKE LINING

BLOCK LININGS FOR HEAVY DUTY TRUCKS AND BUSES

FRIXA CODE	DESCRIPTION	WIDTH	THICKNESS 1	THICKNESS 2	LENGTH OF INSIDE	RADIUS OF INSIDE
540F1B	RB-540 Frt ANCHOR	156.0	17.7	11.3	181.1	199.0
540F2B	RB-540 Frt CAM	156.0	18.5	16.5	184.6	199.0
540R1B	RB-540 Rr ANCHOR	207.5	17.7	11.3	181.1	199.0
540R2B	RB-540 Rr CAM	207.5	18.5	16.5	184.6	199.0
54NR1B	NEW RB-540 Rr ANCHOR	220.0	17.7	11.3	181.1	199.0
54NR2B	NEW RB-540 Rr CAM	220.0	18.5	16.5	184.6	199.0
HT15F	HYUNDAI 15TON F	140.0	15.5		190.7	189.0
HT15R	HYUNDAI 15TON R	200.0	15.5		190.7	189.0
HS15F	HYUNDAI SUPER TRUCK F	156.0	15.5		191.3	189.0
HS15R	HYUNDAI SUPER TRUCK R	220.0	15.5		191.3	189.0
HT20F	HYUNDAI 20TON F	178.0	18.5		197.0	188.0
HT23F1	HYUNDAI 23TON DUMP Frt ANCHOR	178.0	18.0	9.7	196.0	203.0
HT23F2	HYUNDAI 23TON DUMP Frt CAM	178.0	18.3	15.7	196.0	203.0
HT23R1	HYUNDAI 23TON DUMP Rr ANCHOR	220.0	18.5	11.5	197.0	199.0
HT23R2	HYUNDAI 23TON DUMP Rr CAM	220.0	19.5	16.0	197.0	199.0
HT25R1	HYUNDAI 25TON CARGO (SUPER GOLD) Rr ANCHOR	220.0	17.5	11.3	181.0	199.0
HT25R2	HYUNDAI 25TON CARGO (SUPER GOLD) Rr CAM	220.0	18.3	16.4	184.6	199.0
HDTR	HYUNDAI TRAILER	179.0	18.5	15.5	187.0	195.0
HDT01	UNI TRAGO Rr ANCHOR	200.0	19.0	15.3	147.7	199.2
HDT02	UNI TRAGO Rr CAM	200.0	19.0	16.2	147.7	199.2
HDT03	TRAGO DUMP	199.0	19.5	15.0	173.0	199.0
FRTH04	HYUNDAI 5TON F	120.0	11.5		144.6	148.0
FRTH05	HYUNDAI 5TON R	150.0	11.5		144.6	148.0
FRTH06	HYUNDAI AERO TOWN F	110.0	12.6		178.1	171.6
FRTH07	HYUNDAI AERO TOWN R	150.0	12.6		178.1	171.6
FRTH08,09	HYUNDAI 5TON WAGE R	160.0	16.0		155.0	163.0
106NFB	NEW BS-106 F	155.0	18.5		187.6	185.7
106NRB	NEW BS-106 R	220.0	18.5		187.6	185.7
DT15F	DAEWOO 15TON F	139.0	16.0		190.7	189.0
DT15R	DAEWOO 15TON R	177.5	16.0		190.7	189.0
DT16R	NEW DAEWOO 15TON R	203.0	15.0		190.7	188.7
DC15TF	CHASEDAE 15TON F	155.0	15.5		190.7	188.7
DC15TR	CHASEDAE 15TON R	203.0	15.5		190.7	188.7
DC23TR1	CHASEDAE 23TON Rr ANCHOR	178.0	19.0	11.4	196.0	203.0

FRIXA CODE	DESCRIPTION	WIDTH	THICKNESS 1	THICKNESS 2	LENGTH OF INSIDE	RADIUS OF INSIDE
DC23TR2	CHASEDAE 23TON Rr CAM	178.0	20.0	16.4	196.0	203.0
FX212F1	FX-212 F1 ANCHOR	156.0	17.9	11.7	181.0	198.5
FX212F2	FX-212 Frt CAM	156.0	18.5	15.0	184.0	198.5
FX212R1	FX-212 Rr ANCHOR	220.0	17.9	11.7	181.0	198.5
FX212R2	FX-212 Rr CAM	220.0	18.5	15.0	184.0	198.5
FRTD01	NOBUS 5TON R1	160.0	14.5	9.5	160.0	175.7
FRTD02	NOBUS 5TON R2	160.0	15.5	14.6	155.0	175.7
927F1	AM-927 Frt ANCHOR	147.0	17.0	9.7	196.0	197.2
927F2	AM-927 Frt CAM	147.0	17.2	14.5	193.0	197.2
927R1	AM-927 Rr ANCHOR	203.0	17.0	9.7	196.0	197.2
927R2	AM-927 Rr CAM	203.0	17.2	14.5	193.0	197.2
949F	AM-949 F	147.0	15.5		194.8	188.7
949R	AM-949 R	216.0	15.5		194.8	188.7
949NR	AM-949 NR	216.0	15.5		194.8	188.7
AT20	GRANTO 21.5TON	220.0	17.5	12.0	163.0	205.0
88F1	DA-88 Frt ANCHOR	160.0	17.5	10.8	187.8	198.8
88F2	DA-88 Frt CAM	160.0	18.3	16.2	187.8	198.8
88R1	DA-88 Rr ANCHOR	220.0	17.5	10.8	187.8	198.8
88R2	DA-88 Rr CAM	220.0	18.3	16.2	187.8	198.8
SM15TF	SAMSUNG 15TON F	150.0	16.0		190.7	188.7
SM15TR	SAMSUNG 15TON R	220.0	16.0		190.7	188.7
485R1	JINDO TRAILER Rr ANCHOR	177.5	18.6	11.8	191.6	203.2
485R2	JINDO TRAILER Rr CAM	177.5	19.2	16.1	186.0	203.2
DWT01	UD8TON	177.5	16.5		196.0	187.0
ST20F	SCANIA F	177.0	18.8		232.0	188.0
ST20R	SCANIA R	202.0	18.8		232.0	188.0
ST20NR	NEW SCANIA R	249.0	18.8		232.0	188.0
VT20F	VOLVO F	173.0	18.8	14.3	177.0	200.0
VT20R	VOLVO R	199.0	18.8	14.3	177.0	200.0
BT20NF	MERCEDES-BENZ F	183.0	17.0	13.0	178.0	200.0
BT20NR	MERCEDES-BENZ R	220.0	17.0	13.0	178.0	200.0
BPW01	BPW TRAILER	199.0	17.6	12.0	204.0	205.0
ICP01	ICP Rr ANCHOR	220.0	17.7	11.3	181.1	203.0
ICP02	ICP Rr CAM	220.0	18.5	16.5	184.6	203.0

DISC BRAKE PAD

BRAKE SHOE ASSEMBLY

BRAKE LINING

DISC BRAKE PAD

BRAKE SHOE ASSEMBLY

BRAKE LINING

LINING – Only FOR LIGHT TRUCK

FRIXA CODE	DESCRIPTION	WIDTH	THICKNESS 1	THICKNESS 2	LENGTH OF INSIDE	RADIUS OF INSIDE
FRTH01	HYUNDAI 2.5TON	75.0	10.0	10.0	304.0	151.7
FRTH10	HYUNDAI 2.5TON LOW DECK PRI	75.0	5.1	5.1	280.0	145.0
FRTH11	HYUNDAI 2.5TON LOW DECK SEC	75.0	10.0	10.0	320.0	145.0
FRTH02	HYUNDAI 3.5TON OLD	85.0	8.5	8.5	304.0	151.7
FRTH03	HYUNDAI MIGHTY 3.5TON NEW (V/UP)	85.0	10.5	10.5	304.0	149.0
FRTH12	E-MIGHTY 3.5TON	110.0	10.5	10.5	300.0	148.5
FRTH04	HYUNDAI 5TON F	120.0	11.5	11.5	144.6	148.0
FRTH05	HYUNDAI 5TON R	150.0	11.5	11.5	144.6	148.0
FRTH06	HYUNDAI 5TON F (AERO TOWN F)	110.0	12.6	12.6	178.1	171.6
FRTH07	HYUNDAI 5TON R (AERO TOWN R)	150.0	12.6	12.6	178.1	171.6
FRTH08,09	HYUNDAI 5TON (NEW, WEDGE) R1,R2	160.0	16.0	16.0	155.0	163.0
FRTD01	DAWOO NOBUS 5TON R1	160.0	14.5	14.5	160.0	175.7
FRTD02	DAWOO NOBUS 5TON R2	160.0	15.5	15.5	155.0	175.7
FRTK02	KIA 2.5TON (NEW) POWER COMBI F/R	95.0	9.5	9.5	287.0	148.0
FRTK01	KIA 2.5TON JUMBO	75.0	8.0	8.0	304.0	151.7
FRTK03	KIA 5TON RHINO F	110.0	13.0	13.0	294.0	147.0
FRTK04	KIA 5TON RHINO R	125.0	13.0	13.0	294.0	147.0



FRIXA BRAKE SYSTEM

DISC ROTOR

VENTILATED BRAKE DISCS

P. 178 ~

DISC ROTOR

FRIXA BRAKE SYSTEM

We guarantee accurate and safe braking

VENTILATED BRAKE DISCS

This section on Ventilated Brakes Discs provides dimensional details, as well as information on face types and the weight of the most popular discs from the FRIXA disc range. Not all discs are listed, should you require a disc with particular dimensions which is not listed please contact the FRIXA R & D section for assistance.

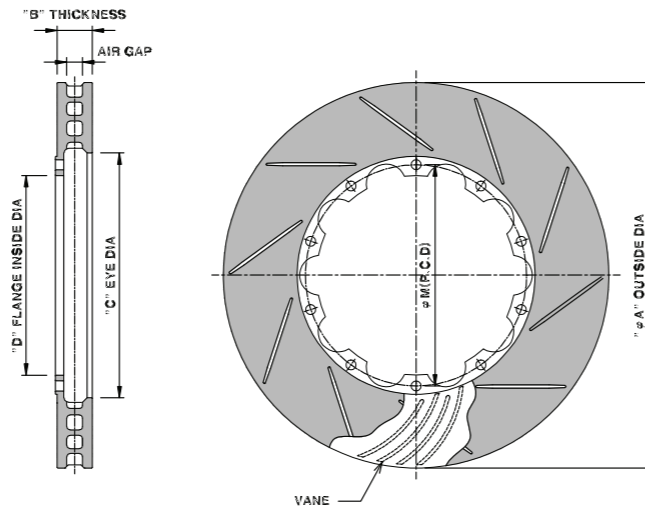

'A' OUTSIDE ϕ	'B' THICKNESS	MOUNTING DETAILS		'C' EYE ϕ	'D' INSIDE FLANGE ϕ	NO. OF VANES	AIR GAP	FACE TYPES	FRIXA CODE
		'M' P.C.D	NO.						
320	27.5	191	10	210	173	68	14	STRAIGHT GROOVE-10	FDR320A
320	32	178	10	195	159	68	14	STRAIGHT GROOVE-10	FDR320B
328	28	202	10	223	183	68	14	STRAIGHT GROOVE-10	FDR328A
330	28	206	10	224	189	68	14	STRAIGHT GROOVE-10	FDR330A
330	20	209.1	12	227.6	197	56	8	STRAIGHT GROOVE-10	FDR330B
330	30	181	10	196	163	68	14	STRAIGHT GROOVE-10	FDR330C
330	28	203.2	12	230	178	68	14	STRAIGHT GROOVE-10	FDR330D
330	27.5	201	10	220	183	68	14	STRAIGHT GROOVE-10	FDR330E
340	28	195	10	215	176	68	14	STRAIGHT GROOVE-10	FDR340A
340	31	195	10	215	176	68	14	STRAIGHT GROOVE-10	FDR340B
350	30	203	10	216	186	70	16	STRAIGHT GROOVE-10	FDR350A
355	32	232	10	253	210	70	16	STRAIGHT GROOVE-10	FDR355A
355	30	225	10	243	206	70	16	STRAIGHT GROOVE-10	FDR355B
355	31	210	10	230	191	70	16	STRAIGHT GROOVE-10	FDR355C
355	30	210	10	231	191	70	16	STRAIGHT GROOVE-10	FDR355D
380	30	246.8	8	265	223	76	16	STRAIGHT GROOVE-12	FDR380A
380	34	223.6	10	241	200	76	18	STRAIGHT GROOVE-12	FDR380B
380	30	235	10	256	213	76	16	STRAIGHT GROOVE-10	FDR380C

VENTILATED BRAKE DISCS

This section on Ventilated Brakes Discs provides dimensional details, as well as information on face types and the weight of the most popular discs from the FRIXA disc range. Not all discs are listed, should you require a disc with particular dimensions which is not listed please contact the FRIXA R & D section for assistance.

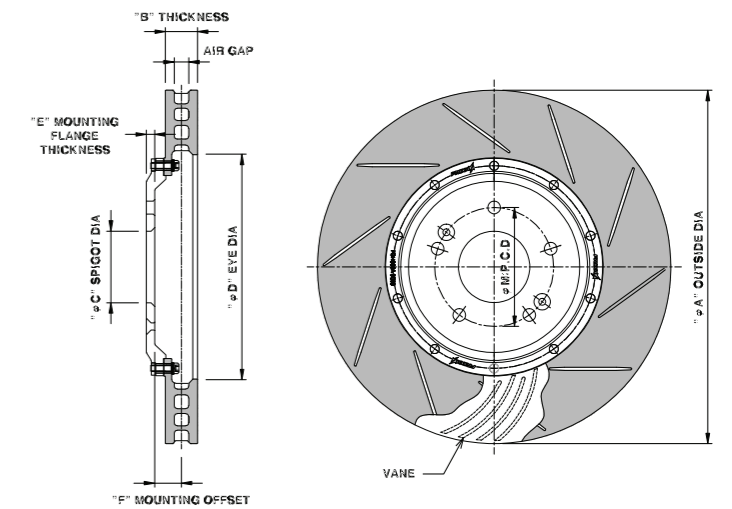

'A' OUTSIDE ϕ	'B' THICKNESS	MOUNTING DETAILS		'C' SPIGOT ϕ	'D' EYE ϕ	'E' MOUNTING FLANGE THICKNESS	'F' MOUNTING OFFSET	NO. OF VANES	AIR GAP	FACE TYPES	FRIXA CODE
		'M' P.C.D	NO.								
320	27.5	114.3	5	69	210	8	25.3	68	14	STRAIGHT GROOVE-10	FDRH320A
320	32	114.3	5	69	195	7.5	21	68	14	STRAIGHT GROOVE-10	FDRH320B
320	27.5	114.3	5	68	210	8	26.7	68	14	STRAIGHT GROOVE-10	FDRH320C
328	28	112	5	65.1	223	7.5	28.5	68	14	STRAIGHT GROOVE-10	FDRH328A
330	28	114.3	5	60	224	8	25.4	68	14	STRAIGHT GROOVE-10	FDRH330A
330	20	114.3	5	69	227.6	8	43.6	56	8	STRAIGHT GROOVE-10	FDRH330B
330	30	114.3	5	69	196	8	29	68	14	STRAIGHT GROOVE-10	FDRH330C
330	28	114.3	5	70.7	230	8	25.4	68	14	STRAIGHT GROOVE-10	FDRH330D
330	27.5	114.3	5	69	220	8	25.3	68	14	STRAIGHT GROOVE-10	FDRH330E
340	28	114.3	5	69	215	8	34.5	68	14	STRAIGHT GROOVE-10	FDRH340A
340	31	114.3	5	69	215	8	25.8	68	14	STRAIGHT GROOVE-10	FDRH340B
350	30	139.7	5	96.3	216	8	36	70	16	STRAIGHT GROOVE-10	FDRH350A
355	32	180	10	165	253	6	47.5	70	16	STRAIGHT GROOVE-10	FDRH355A
355	30	114.3	5	69	243	9	27	70	16	STRAIGHT GROOVE-10	FDRH355B
355	31	114.3	5	69	230	8	25.8	70	16	STRAIGHT GROOVE-10	FDRH355C
355	30	114.3	5	69	231	8	26	70	16	STRAIGHT GROOVE-10	FDRH355D
355	30	114.3	6	69	231	8	26	70	16	STRAIGHT GROOVE-10	FDRH355E
380	30	114.3	5	69	241	8	26	76	16	STRAIGHT GROOVE-10	FDRH380C
380	30	114.3	6	69	256	8	26	76	16	STRAIGHT GROOVE-10	FDRH380D



CONFIDENCE IN PERFECT CONTROL! - **FRIXA**

EXTREME BRAKE SYSTEM



DISC ROTOR



PREMIUM BRAKE PAD
S1 SERIES



| Тел./факс: +7 (495) 926-37-31 | e-mail: info@hankook-frixa.ru | www.hankook-frixa.ru